

**Continental**   
The Future in Motion

**GASOLINE  
DIESEL**



**Powertrain Solutions**  
Technical Information

## Powertrain. Energy for Your Drive.



Safe, eco-friendly driving with your own vehicle – arrive relaxed at your destination. Few things fascinate people around the world like the issue of mobility. At the same time, mobility today is undergoing fundamental changes.

We are one of the leading developers and manufacturers of solutions for efficient combustion engines and after all pioneers in the field of efficient system technology and economical vehicle integration in electric vehicles using electric power as an additional energy source.

Both fields of innovation ultimately pursue the same goal: Lowering CO<sub>2</sub> and emissions. This is the goal pursued by the Powertrain division in the five solution areas electrification, connected energy management, combustion, exhaust after-treatment and drivetrain efficiency.

## Content

### Powertrain Solutions



Electrification



Connectivity



Combustion  
Systems Diesel



Combustion  
Systems Gasoline



After-treatment



Efficiency

### Vehicle Applications



Passenger Cars



Off-Highway



Trucks and Buses



Recreation



2-Wheelers



Marine

### 12 System Overviews

- 12 Diesel Injection and After-treatment System
- 14 Gasoline Direct Injection System
- 16 Gasoline Port Fuel Injection System
- 18 High Voltage Electrification
- 20 48 Volt Electrification

# Content

---

## 22 Electrification Solutions

### Hybrid & Electric Vehicle

- 24 HV Axle Drive with Integrated Inverter
- 25 HV Power Electronics, Inverter + DC/DC Converter
- 26 HV Inverter
- 27 HV DC/DC Converter
- 28 HV Battery Management System (BMS)
- 29 HV Battery Junction Box (BJB)

### Engine Systems

- 30 HV Battery On-Board Charger
- 31 HV Battery Wireless Power Transfer System

### Hybrid & Electric Vehicle

- 32 HV Axle Drive and Charging
- 33 HV Boost Converter

### Engine Systems

- 34 Vehicle Control Unit
- 35 48 V eCompressor

### Hybrid & Electric Vehicle

- 36 48 V Air Cooled Belt Starter Generator (BSG)
- 37 48 V Liquid Cooled Belt Starter Generator (BSG)
- 38 48 V DC/DC Converter
- 39 48 V Battery Management System

### Transmission

- 40 Control Unit for Double Clutch Transmission
- 41 Control Unit for Stepped Automatic Transmission

### Sensors & Actuators

- 42 Electrical Water Pump
- 43 Temperature Sensor - Coolant
- 44 Coolant Flow Control Valve - Non-Smart
- 45 Coolant Flow Control Valve - Smart

---

## 46 Electrification Solutions

### Hybrid & Electric Vehicle

- 46 12 V Dual Battery Management System
- 47 12 V Power Net System

### Sensors & Actuators

- 48 Brushless DC Motor for Brake Applications

---

## 50 Connectivity Solutions

### Sensors & Actuators

- 52 Door Handle Sensor
- 53 Door Handle Sensor with NFC Reader
- 54 Door Handle Sensor BLE
- 55 Easy Trunk Access Sensor

---

## 56 Combustion Solutions

### Engine Systems

- 58 Customized Fuel Delivery Module
- 59 Diesel Dosing Injector
- 60 Diesel Fuel Rail
- 61 Diesel High Pressure Pump DHP1.1
- 62 Diesel High Pressure Pump DHP2
- 63 Diesel High Pressure Pump DHP3
- 64 Diesel Piezo Common Rail Injector PCR55
- 65 Diesel Pressure Decay Valve PDV 1-25
- 66 ECU Bi-Fuel Ready-to-Use EasyU
- 67 ECU Diesel Heavy Duty Engines
- 68 Piezo Common Rail
- 69 ECU Diesel Platform for Commercial Vehicles
- 70 ECU Gasoline Port Fuel Injection
- 71 ECU Gasoline Port Fuel Injection Ready-to-Use EasyU

## Content

---

### 72 Combustion Solutions

- 72 ECU Gasoline SDI and TCU
- 73 ECU Gasoline SDI Ready-to-Use EasyU
- 74 ECU Gasoline Solenoid Direct Injection
- 75 ECU M3B (Air Module)
- 76 ECU M3C
- 77 ECU M4D Ride By Wire
- 78 ECU M4L/XE Air Module
- 79 EMS3 Engine Management System Platform
- 80 Gasoline Deka 10 Port Fuel Injector
- 81 Gasoline Deka 7/9 Port Fuel Injector
- 82 Gasoline DI XL3.1 Solenoid Injector
- 83 Gasoline DI XL5 Solenoid Injector
- 84 Gasoline Fuel Rail Assembly
- 85 Gasoline High Pressure Pump GHP2.5 DI/PFI
- 86 Gasoline High Pressure Pump GHP2.5
- 87 Gasoline Turbocharger with Aluminum Turbine Housing
- 88 Gasoline Turbocharger with Steel Turbine Housing
- 89 Gasoline Turbocharger with VRAAX™ Turbine Technology
- 90 Ignition Coil
- 91 Oxygen Sensor

#### Sensors & Actuators

- 92 Active Purge Pump
- 93 Air Control Valve Economy Line S11.1
- 94 Air Control Valve - Performance Line S8.6
- 95 Air Control Valve 12 - Modular Performance
- 96 Air Control Valve 12 - Modular Performance
- 97 Brushless DC Drives High Efficiency
- 98 Canister Purge Solenoid CPS6

---

### 99 Combustion Solutions

- 99 Digital Linear Actuator Compact Size - Gen VII
- 100 Digital Linear Actuator Standard Size - Gen I
- 101 Digital Linear Actuator Standard Size - Gen II
- 102 Digital Linear Actuator Standard Size - Gen V
- 103 Electrical Compressor Bypass Valve
- 104 Electrical Exhaust Gas Recirculation Valve
- 105 Electronic Throttle Control 11.2 - Economy Line
- 106 Electronic Throttle Control ETC 12 - Modular Perform.
- 107 Electronic Throttle Control 13 - Economy Line
- 108 Electrical Wastegate Actuator
- 109 Exhaust Control Valve - High Pressure
- 110 Exhaust Control Valve - Linear
- 111 Exhaust Control Valve - Low Pressure
- 112 Fluid Sensor - Flex Fuel Ethanol
- 113 Fluid Sensor - Oil Level Passive Electrothermic
- 114 Fluid Sensor - Oil Level Switch
- 115 Fluid Sensor - Oil Level Ultrasonic
- 116 In Cylinder Pressure Sensor
- 117 Knock Sensor M6 Small Design
- 118 Knock Sensor M8 Standard Design
- 119 Latching Valve
- 120 Linear Purge Valve
- 121 Natural Vacuum Leak Detection (NVLD III)
- 122 Pressure Sensor - Brake Booster Absolute
- 123 Pressure Sensor - Brake Booster Gauge
- 124 Pressure Sensor - Filter Control Gauge
- 125 Pressure Sensor - Filter Control Gauge - Air Filter Pressure
- 126 Pressure Sensor - Filter Control Gauge - Diesel Crankcase Pressure

# Content

---

## 127 Combustion Solutions

- 127 Pressure Sensor - Filter Control Gauge - Gasoline Crankcase Pressure
- 128 Pressure Sensor - Fuel Vapor Gauge
- 129 Pressure Sensor - High Pressure Diesel
- 130 Pressure Sensor - High Pressure Gasoline
- 131 Pressure Sensor - Manifold Absolute - MAP TMAP BAP
- 132 Pressure Sensor - Manifold Absolute and Temperature
- 133 Pressure Sensor - Manifold Gauge
- 134 Temperature Sensor - High Single
- 135 Temperature Sensor - Coolant / Fuel / Oil
- 136 Turbo Purge Valve
- 137 Variable Compression Ratio (VCR) Actuator
- 138 Variable Turbine Geometry Actuator

---

## 140 Exhaust After-treatment Solutions

### Engine Systems

- 142 After-treatment Control Module
- 143 Air-Cooled SCR Injector
- 144 Liquid-Cooled SCR Injector
- 145 Urea Dosing Control Unit

### Fuel & Exhaust Management

- 146 CS-Design (Crossversal Structure)
- 147 LS-Design® (Longitudinal Structure)
- 148 LS-Design® and PE-Design®
- 149 MX-Design® (Mixing Structure)
- 150 PE-Design® (Perforated Structure)
- 151 TS-Design® (Transversal Structure)
- 152 Straight Channel METALIT® (Standard Structure)
- 153 Thin Wall and Lightweight Catalyst
- 154 Controller for Electrically Heated Catalyst (EMICAT®)

---

## 155 Exhaust After-treatment Solutions

- 155 EMICAT® Electrically Heated Catalyst
  - 156 Three-Way Catalyst (TWC)
  - 157 Diesel Oxidation Catalyst (DOC)
  - 158 SCR Catalyst
  - 159 SCR Light-Off Catalyst
  - 160 Exhaust After-treatment System for Two-Wheeler
  - 161 Close-Coupled After-treatment System Gasoline
  - 162 Close-Coupled After-treatment System Light-Duty (LDD)
  - 163 Compact Catalyst
  - 164 Compact SCR EHC System Light Duty (LDD)
  - 165 Sensor Catalyst
  - 166 Close-Coupled After-treatment System Heavy-Duty (HDD)
  - 167 Close-Coupled Oxidation Catalyst Heavy-Duty (HDD)
  - 168 Universal Decomposition Pipe (UDP)
  - 169 Ring-Shape DOC for Advanced Compact SCR
  - 170 Ring Catalyst
  - 171 Ring-Shape SCR EHC System
  - 172 Particulate Matter Filter PM-METALIT®
  - 173 Exhaust Gas Recirculation Filter
  - 174 Metallic Gasoline Particle Filter
  - 175 Air-Assisted Urea Dosing Unit UDA
  - 176 Tank-Integrated SCR Urea Extraction Unit Gen 4
  - 177 Tank-Integrated SCR Urea Extraction Unit Gen III
- ### Sensors & Actuators
- 178 Electrostatic Particulate Matter Sensor
  - 179 Fluid Sensor - Urea Concentration and Level
  - 180 Mass Airflow Sensor - FMT MAF SENT
  - 181 Mass Airflow Sensor - FMT MAF+HPT SENT

# Content

---

## 182 Exhaust After-treatment Solutions

- 182 Mass Airflow Sensor - MT MAF
- 183 Pressure Sensor - Particle Filter/EGR Differential
- 184 Pressure Sensor - Particle Filter Gauge (Single Port)
- 185 Pressure Sensor - Secondary Air Absolute
- 186 Smart NO<sub>x</sub> Sensor - Gen 4.0A
- 187 Smart NO<sub>x</sub> Sensor - Gen 4.0P
- 188 Temperature Sensor - EGR
- 189 Temperature Sensor - High Multiple

---

## 190 Drivetrain Efficiency Solutions

### Fuel & Exhaust Management

- 192 Electric Fuel Pump - EC
- 193 Electric Fuel Pump - DC
- 194 Fuel Delivery Module for Entry Level Vehicles
- 195 Fuel Delivery Module for High-End Applications
- 196 Fuel Delivery Module for Standard Applications
- 197 Fuel Level Sensor with an Open Contact System
- 198 Fuel Level Sensor with a Sealed Contact System
- 199 Fuel Delivery Controller
- 200 Tank Domain Controller

### Sensors & Actuators

- 201 Position Sensor - Linear Contactless
- 202 Position Sensor - Rotary Contactless
- 203 Position Sensor - Rotary or Linear Contactless
- 204 Twin Drive Pump
- 205 Smart Position Sensor Cover

### Transmission

- 206 Control Unit for Double Clutch Transmission
- 207 Control Unit for Double Clutch Transmission

---

## 208 Drivetrain Efficiency Solutions

- 208 Control Unit for Double Clutch Transmission
- 209 Control Unit for Double Clutch Transmission
- 210 Control Unit for Double Clutch Transmission
- 211 Control Unit for Double Clutch Transmission
- 212 Control Unit for Double Clutch Transmission
- 213 Control Unit for Double Clutch Transmission
- 214 Control Unit for Double Clutch Transmission
- 215 Control Unit for Double Clutch Transmission
- 216 Control Unit for Automatic Transmission
- 217 Control Unit for Stepped Automatic Transmission
- 218 Control Unit for Stepped Automatic Transmission
- 219 Control Unit for Stepped Automatic Transmission
- 220 Control Unit for Stepped Automatic Transmission
- 221 Control Unit for Continuously Variable Transmission
- 222 Universal Transmission Control Unit
- 223 Universal Transmission Control Unit Platform
- 224 Electronic Control Unit for Limited Slip Coupling
- 225 Universal Control Unit for Powertrain Applications
- 226 Transfer Case Actuator
- 227 Multi Position Linear Actuator
- 228 Direct Shift Module
- 229 Sensorcluster for Wet Double Clutch Transmissions
- 230 Smart Actuator Platform
- 231 Control Unit for Automated Manual Transmission (CV)
- 232 Control Unit for Double Clutch Transmission (CV)
- 233 Electronic Clutch Actuator (CV and Off-Highway)

## Diesel Injection and After-treatment System

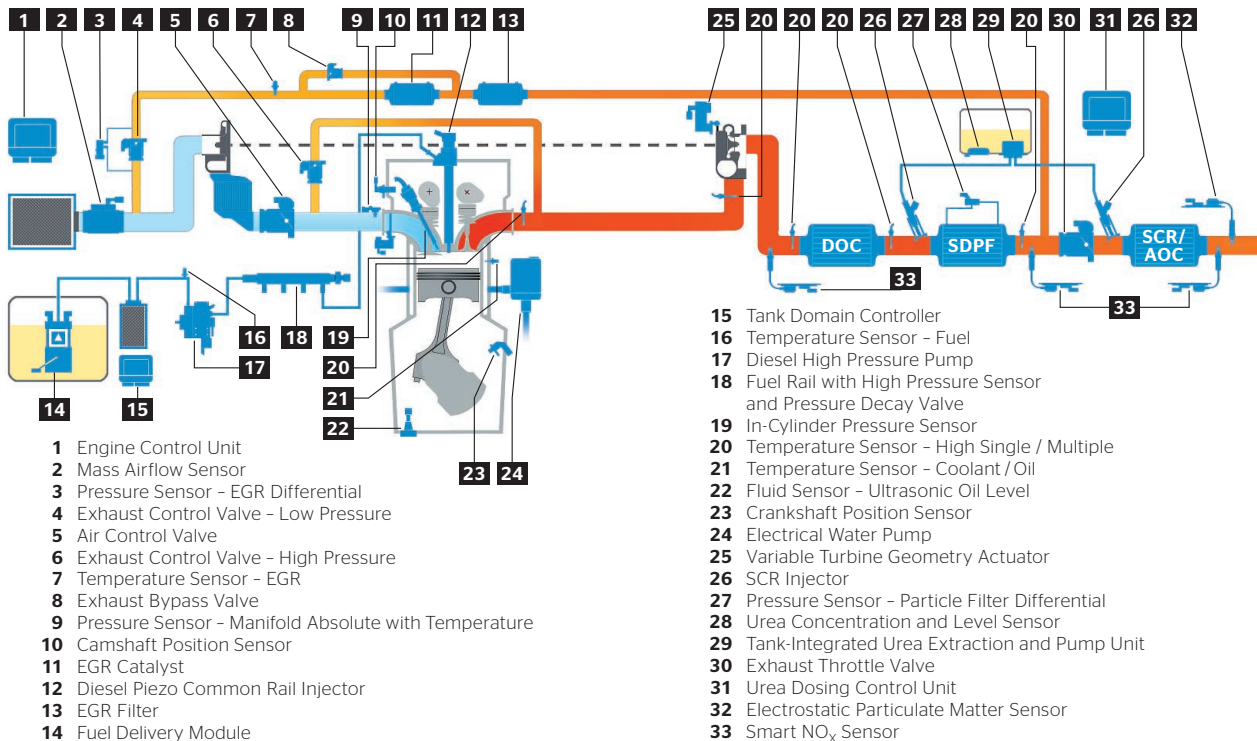

## Gasoline Direct Injection System

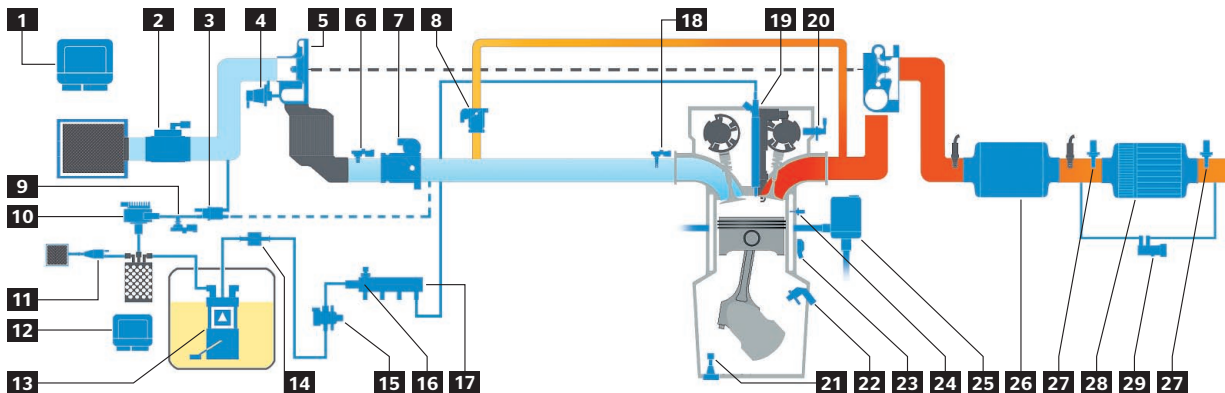

- |  |  |
|--|--|
| <b>1</b> Engine Control Unit                         | <b>16</b> Fuel High Pressure Sensor  |
| <b>2</b> Mass Airflow Sensor                         | <b>17</b> Fuel Rail  |
| <b>3</b> Turbo Purge Valve / Canister Purge Solenoid | <b>18</b> Pressure Sensor - Manifold Absolute and Temperature                  |
| <b>4</b> Electrical Compressor Bypass Valve          | <b>19</b> Gasoline Direct Injection Solenoid Injector                          |
| <b>5</b> Turbocharger                                | <b>20</b> Active Camshaft Position Sensor                                      |
| <b>6</b> Pressure Sensor - Manifold Absolute         | <b>21</b> Fluid Sensor - Ultrasonic Oil Level                                  |
| <b>7</b> Electronic Throttle Control                 | <b>22</b> Active Crankshaft Position Sensor<br>(also with Direction Detection) |
| <b>8</b> Exhaust Control Valve - High / Low Pressure | <b>23</b> Knock Sensor   |
| <b>9</b> Pressure Sensor - EVAP                      | <b>24</b> Temperature Sensor - Coolant   |
| <b>10</b> Active Purge Pump                          | <b>25</b> Electrical Water Pump  |
| <b>11</b> Latching Valve                             | <b>26</b> Three-Way Catalyst   |
| <b>12</b> Tank Domain Controller                     | <b>27</b> Temperature Sensor - High Single / Multiple                          |
| <b>13</b> Fuel Delivery Module                       | <b>28</b> Gasoline Particle Filter   |
| <b>14</b> Fluid Sensor - Flex Fuel Ethanol Sensor    | <b>29</b> Pressure Sensor - Particle Filter Differential                       |
| <b>15</b> Gasoline High Pressure Pump                |  |

## Gasoline Port Fuel Injection System

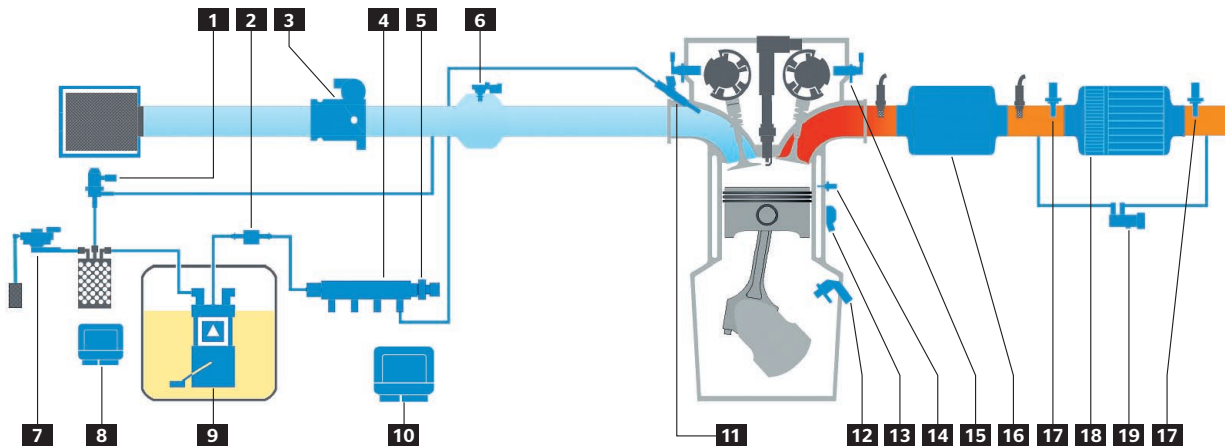

- 1 Canister Purge Solenoid
- 2 Fluid Sensor - Flex Fuel Ethanol Sensor
- 3 Electronic Throttle Control
- 4 Fuel Rail
- 5 Pressure Regulator
- 6 Pressure Sensor - Manifold Absolute and Temperature
- 7 Natural Vacuum Leak Detection (NVLD III)
- 8 Tank Domain Controller
- 9 Fuel Delivery Module
- 10 Engine Control Unit

- 11 Gasoline Port Fuel Injector
- 12 Active Crankshaft Position Sensor (also with Direction Detection)
- 13 Knock Sensor
- 14 Temperature Sensor - Coolant
- 15 Active Camshaft Position Sensor
- 16 Three-Way Catalyst
- 17 Temperature Sensor - High Single / Multiple
- 18 Gasoline Particle Filter
- 19 Pressure Sensor - Particle Filter Differential



## 48 Volt Electrification

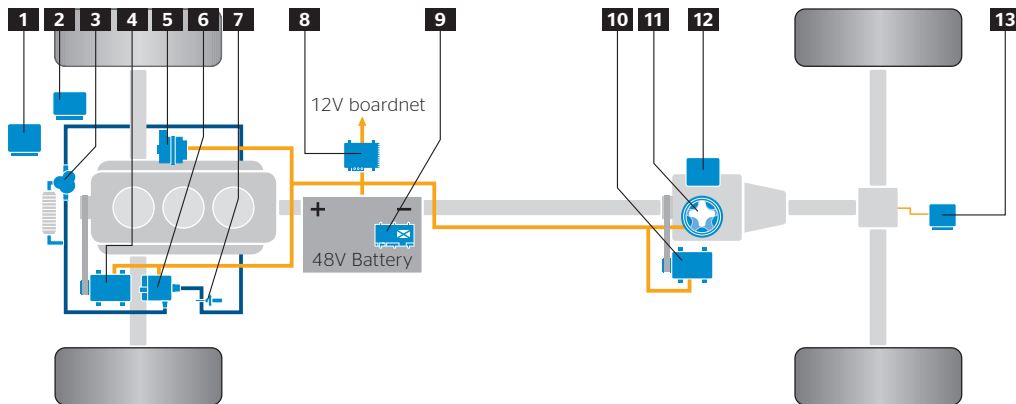

- 1 Engine Control Unit
- 2 Vehicle Control Unit
- 3 Coolant Flow Control Valve
- 4 48V Belt Starter Generator (P0)
- 5 48V eCompressor
- 6 Electrical Water Pump
- 7 Temperature Sensor - Coolant
- 8 DC/DC Converter
- 9 Battery Management System

- 10 48V Starter Generator (P2)
- 11 Transmission Oil Pump
- 12 Transmission Control Unit
- 13 Torque Transfer Device Control Unit

— Electric circuit  
— Coolant circuit

## Electrification Solutions

### A Jack of All Trades

Continental Powertrain is a pioneer in electrifying vehicle drives in both hybrid and electric vehicles.

We are a leading system supplier of technology, from development to industrialization and series production applications. Here, we focus our innovations on achieving a healthy cost-benefit ratio, since only economical and practical solutions will find their way into series production. It is exactly this kind of tailor-made electrification that has made us a pioneer in mild hybridization with 48V Eco Drive technology: Providing a low cost hurdle in terms of integration, this system results in fuel savings of up to 21 percent in urban traffic. Another focus is on making smart use of the new opportunities that come along with electrification - including new forms of interaction.

These include, for example, more electrically driven components and economical power-on-demand functions. Electricity is a jack of all trades in these kinds of applications.

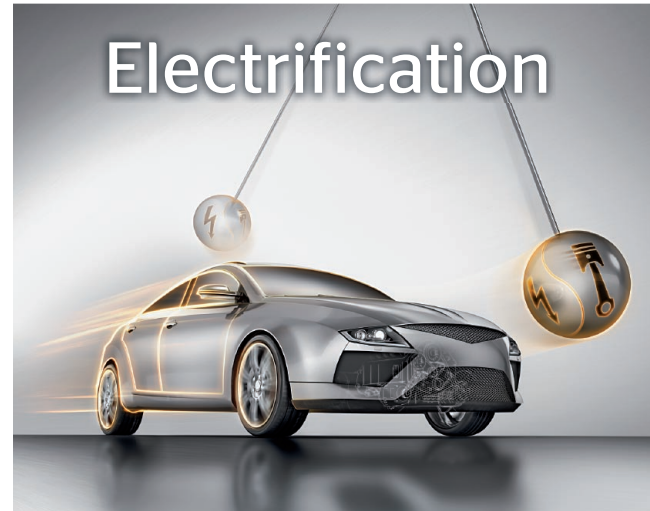

## HV Axle Drive with Integrated Inverter

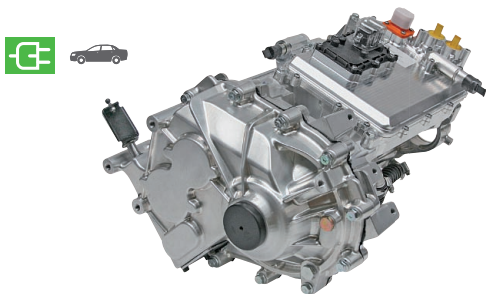

Highly integrated electric drive system. Reduced efforts at customer for integration, sourcing, validation.

### Benefits

- › Integration of motor, inverter, and reducer
- › No connectors, no cables between motor and inverter, easier vehicle assembly
- › Scalability through variable rotor/stator length
- › EV-series-proven technologies
- › Lower vehicle integration effort

### Technical Information

- › Max. torque (machine): 310 Nm
- › Gear ratio: 1:7.5 up to 1:10
- › Max. machine power: 140 kW up to 160 kW
- › Continuous power: 65 kW
- › High power variant with 600 Nm, 250 kW peak
- › High power density provides compact packaging

## HV Power Electronics Inverter + DC/DC Converter

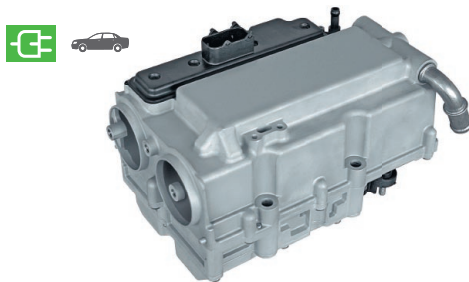

Drives electric machine in traction and generator mode. Converts energy between HV battery and 12 V boardnet.

### Benefits

- › Sintered power stage for maximum reliability
- › Very high power density
- › Inverter: Motor and generator mode, DC/DC: Buck and boost mode
- › For hybrid and electric vehicle applications
- › Modular design for standalone and integrated solutions

### Technical Information

- › Inverter performance: Up to 450 V / 450 A peak
- › DC/DC: 3.6 kW peak / 3 kW cont.
- › AUTOSAR compliant SW architecture
- › Safety Level: Inverter ASIL C  
DC/DC ASIL C optional

## HV Inverter

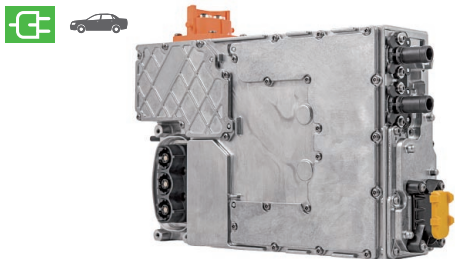

High power inverter for driving the electric machine in traction and generator mode.

### Benefits

- › Sintered power stage for maximum reliability
- › Increased peak and cont. power for high power applications
- › Motor and generator mode
- › For hybrid and electric vehicle applications

### Technical Information

- › Inverter performance: Up to 460 V/600 A peak
- › AUTOSAR compliant SW architecture
- › Safety Level: ASIL C

## HV DC/DC Converter

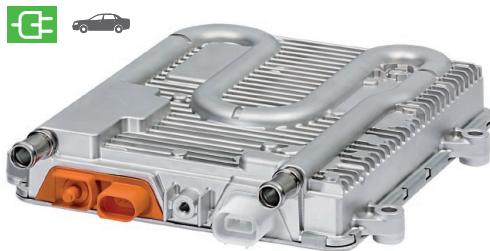

Ensures energy flow between the high voltage and the low voltage boardnet in hybrid and electric vehicles.

### Benefits

- › Precharge function from 0 V
- › AUTOSAR compliant SW architecture
- › Buck and boost mode for bi-directional energy flow
- › Customizable for input voltages of 800 V and output voltages of 48 V
- › For hybrid and electric applications

### Technical Information

- › DC/DC power scalable up to 3.6 kW
- › Output current one phase: 160 A at 14.5 V cont.
- › Output current two phase: 250 A at 14.5 V cont.
- › Nom. operating voltage range HV: 250 V up to 475 V
- › Nom. operating voltage range LV: 9 V up to 16 V
- › Temperature range: -40°C up to +85°C
- › Safety Level: ASIL B (D), ASIL C optional

## HV Battery Management System (BMS)



Manages all functions of the high voltage Li-Ion battery applied to hybrid and electric vehicles.

### Benefits

- › Calculates state of charge and state of health of battery cells
- › Controls internal and external actuators like contactors, cooling pumps, etc.
- › Scalable design, compact size, and weight
- › Modular structure including the Battery Management Controller and the Cell Supervising Circuit

### Technical Information

- › Monitoring of Li-Ion cells for 400 V / 800 V systems
- › Integrated HV system isolation measurement
- › Scalable monitoring of cell temperatures
- › Scalable contactor control and monitoring
- › Multiple options for battery current measurement
- › Integrated cell balancing
- › AutoSAR compliant software

## HV Battery Junction Box (BJB)



Interfaces the battery cell stack with the vehicle high voltage powertrain and the charging devices.

### Benefits

- › Localized HV interfaces and ease of servicability
- › Customizable to various battery designs, packaging, and cooling concepts
- › High power applications including fast DC charging
- › Possibility to integrate others electronics components (BMS / DC/DC)

### Technical Information

- › Separate HV / high current interfaces to the vehicle (e.g. inverter, chargers, auxiliaries)
- › Contains switching and overcurrent protection components
- › Charging Power: Up to 350 kW
- › Voltage Range: Up to 800 V

## HV Battery On-Board Charger



Generic platform for conductive charging: Recharge high-voltage battery from power grid.

- Benefits**
- › Useable for Plug-In hybrid and electric vehicles
  - › Electronic topology for worldwide charging use case
  - › Galvanic isolated power transfer
  - › Support wide range of AC grid voltages
  - › Bidirectional charging possible
  - › Diagnostic via OBD / CAN FD
- Technical Information**
- › Charging power: Up to 11 kW
  - › Grid supply: AC in 110 V - 240 V / 400 V
  - › HV battery: DC out 220 V - 470 V
  - › Housing: IP6K9; 3 g RMS
  - › Software: Continental SW opt. AUTOSAR
  - › Interfaces: CAN FD, Power Line Communication

## HV Battery Wireless Power Transfer System



11 kW unidirectional charger for wireless power transfer.

- Benefits**
- › Vehicle pad incl. controls and power electronics
  - › Ground pad incl. control unit and system functions
  - › Positioning system
  - › Electronic topology for worldwide charging use case
  - › Topology for high power density package
- Technical Information**
- › Charging power: 3.6 kW up to 11 kW (WPT class 1,2,3)
  - › Air gap: Z up to 21 cm
  - › Air gap monitoring: Living + foreign object detection
  - › Communication: WiFi and P2P
  - › Positioning: LF magnetic system
  - › Grid supply: AC in 110 V - 240 V, 1-3 phases
  - › HV battery: DC out 220 V - 470 V
  - › Software: AUTOSAR based multicore

## HV Axle Drive and Charging

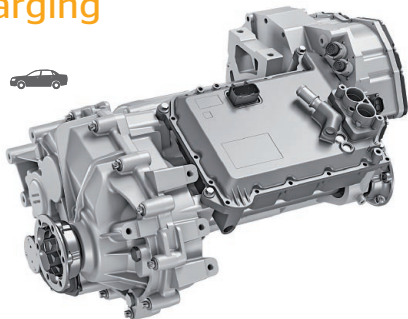

Axle Drive extended with charging functions for a wide range of charging options.

### Benefits

- › In traction and recuperation mode, it works like a conventional Axle Drive
- › In charging mode, it substitutes the on-board charger
- › Single speed transmission
- › Parking lock

### Technical Information

- › Up to 12 times faster charging than state-of-the-art
- › Charging mode: 1 and 3-phase AC charging
- › Charging mode: Bi-directional operation (Vehicle-2-X)
- › Power: Up to 140 kW power
- › Torque: Up to 3,100 Nm
- › Charging power: Up to 43 kW (4 km/min) AC charging
- › DC-link Voltage: Variable up to 800 V

## HV Boost Converter



Ensures an optimally controlled power flow between drivetrain or charging interface to the battery.

### Benefits

- › Higher current at low battery voltage
- › Silicon carbide technology
- › Water-cooled
- › Active discharge

### Technical Information

- › Reduce DC fast charge time by 10 %
- › Increase machine efficiency by supplying SoC independent traction power
- › Current gradient: Up to 100 A/ms
- › Efficiency: > 98 %
- › DC-link Voltage: Variable up to 800 V
- › 800 V fast charging with 400 V battery
- › Power: Up to 150 kW (at 800 V/400 V conversion)

## Vehicle Control Unit

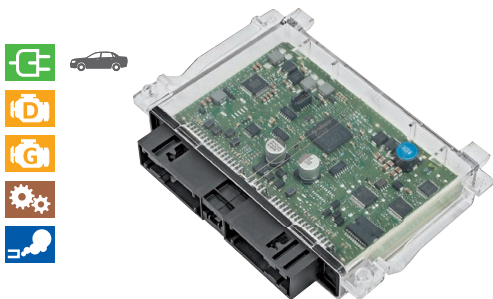

Calculates and distributes torque request to various power-train control units (engine, e-motor, battery, transmission).

- Benefits**
- › Enables CO<sub>2</sub> savings via predictive driving algorithms
  - › Communications gateway
  - › For passenger vehicles (12 V)
  - › Central home for connected functions leads to reduced number of ECU variants

- Technical Information**
- › Core: Tricore multicore architecture
  - › Flash size: Up to 16 MB
  - › Interfaces: CAN FD, LIN, FlexRay, SENT, Ethernet
  - › Drivers: High-/low-side, H-bridges
  - › Housing: Plastic, 2 connector chambers
  - › Connector pins: 68
  - › ISO 26262, AUTOSAR 4.2

## 48 V eCompressor

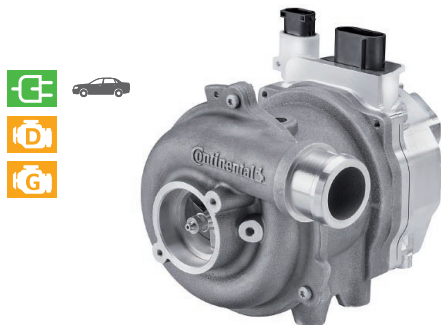

Electrically-driven radial compressor to improve transient response and low end torque.

- Benefits**
- › Extended boost duration
  - › Allows optimized turbo matching
  - › Compensates impact of reduced scavenging
  - › Supports fuel economy concepts
  - › Customer specific aerodynamic design
  - › Favorable acoustic characteristics
- Technical Information**
- › Permanent-magnet synchronous motor with low harmonic content
  - › Supply voltage: 48 V
  - › Peak shaft power: 5 kW
  - › Response time: < 250 ms
  - › Water-cooled
  - › CAN interface
  - › High speed bearing system

## 48 V Air-Cooled Belt Starter Generator (BSG)

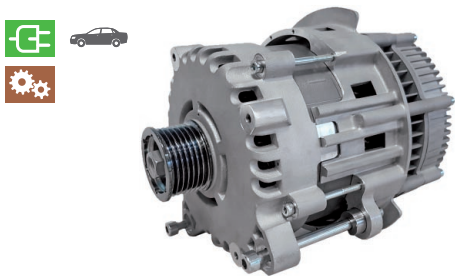

Cost-efficient, compact solution for mass hybridization. Advanced start-stop, coasting, and electric boost.

- Benefits**
- › Air-cooled BSG with high power density and integrated inverter
  - › Generates high CO<sub>2</sub> benefits together with significant drivability improvements
- Technical Information**
- › Peak torque: 60 Nm
  - › Peak power: 12 kW in generator mode
  - › Speed: Up to 20,000 rpm continuous
  - › Weight: < 10 kg
  - › Ambient temperature: -40°C up to +120°C
  - › Cold start approved at -30°C
  - › Stack length adjustable (40 up to 80 mm)
  - › Safety: ASIL-B

## 48 V Liquid-Cooled Belt Starter Generator (BSG)

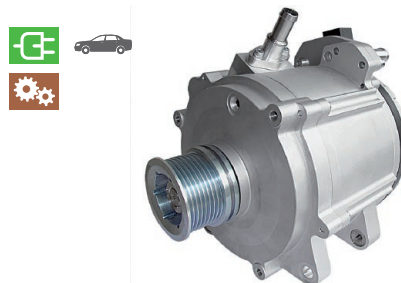

High performance, cost efficient mild hybrid solution. Advanced start-stop, coasting, and electric boost.

- Benefits**
- › Liquid-cooled BSG with highest power density
  - › Generates high CO<sub>2</sub> benefits together with significant drivability improvements
  - › IP6K9K, robustness against water and dirt
  - › No debris/dust, no service required
- Technical Information**
- › Peak torque: 60 Nm
  - › Peak power: 15 kW in generator mode
  - › Speed: Up to 20,000 rpm continuous
  - › Weight: < 12 kg
  - › Ambient temperature: -40°C up to +140°C
  - › Cold start approved at -30°C
  - › Stack length adjustable (40 up to 80 mm)
  - › Safety: ASIL-B

## 48 V DC/DC Converter

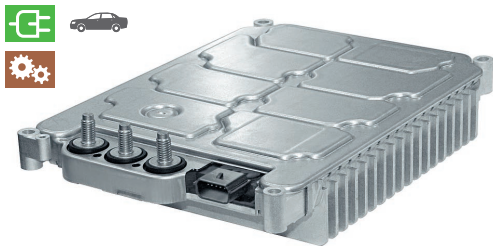

Stabilizes and connects the 12 V power net and 48 V power net for advanced start-stop, coasting, and electric boost.

- Benefits**
- › Bi-directional DC/DC converter 48 V - 12 V
  - › 12 V boardnet stabilization
  - › Pre-charging function for 48 V DC-link
  - › Self-protection
  - › Digital voltage and current control
- Technical Information**
- › Power (buck mode): Up to 3 kW cont.; 215 A
  - › Power (boost mode): Up to 2.8 kW cont.; 58 A
  - › Efficiency: > 95%
  - › Input voltage: 24 V up to 54 V (VDA320 compl.)
  - › Output voltage: 6 V up to 16 V
  - › Protection class: IP6k2
  - › Safety: ASIL C

## 48 V Battery Management System

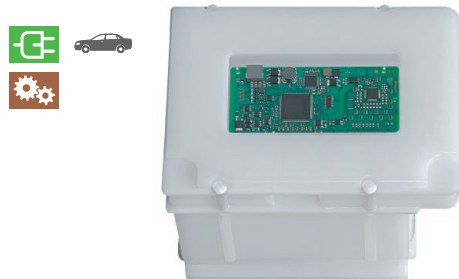

Manages all functions of the 48 V Li-Ion battery. Cells are individually balanced and operated under safe conditions.

- Benefits**
- › Measurement of cell voltage, battery current, and cell temperature
  - › Integrated cell balancing
  - › Contactor control and pre-charge function
  - › Calculation of state of charge, available power, and battery health
- Technical Information**
- › Complete circuitry on 1 single Printed Circuit Board
  - › Crash signal sensing and reaction
  - › Supervises up to 14 cells
  - › Quiescent current: < 250  $\mu$ A
  - › Cell voltage measurement range: 0 V up to 5 V
  - › Operating temperature: -40°C up to +85°C
  - › Battery current: +/-500 A (with 100  $\mu$ Ohm shunt)
  - › AutoSAR compliant software

## Control Unit for Double Clutch Transmission

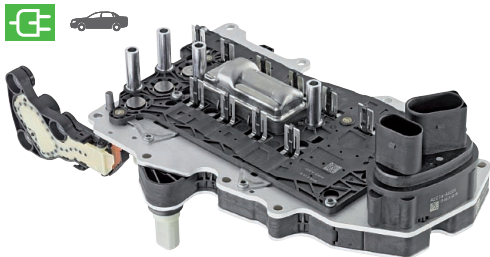

Control unit for wet 6-speed Double Clutch Transmission for hybrid applications and electrified powertrains.

- Benefits**
- › Control module including sensorics
  - › Control of clutch and gearshift actuators
  - › Additional control of disconnection clutch to the e-motor
  - › Control of electrical oil pump
- Technical Information**
- › Substrate: Bare-Die High-Density Interconnect
  - › Operating temperature: -40°C up to +140°C
  - › 32-bit microcontroller
  - › Sensors: 2 temperature (integrated), 1 rotary position, 2 speed, 3 pressure, 4 gear shift position
  - › Actuators: Connectors to 11 valves
  - › Functional safety level: ASIL B

## Control Unit for Stepped Automatic Transmission



Control unit for 7-speed Stepped Automatic Transmission and Electric Transmission Oil Pump.

- Benefits**
- › Integrated in transmission
  - › Mechatronic module mounted on valve body
  - › Control of additional transmission oil pump for full electric drive
- Technical Information**
- › Substrate: LTCC
  - › Operating temperature: -40°C up to +140°C
  - › 32-bit microcontroller
  - › Sensors: 3 speed, 1 pressure, 2 temperature, 1 position selector lever, 2 pressure switch
  - › Actuators: 10 power outputs for solenoids

## Electrical Water Pump



Centrifugal pump based on a modular design concept.

- Benefits**
- › Supports energy management (on demand)
  - › Operation independent from main cooling circuit and from combustion engine operation
- Technical Information**
- › Wet-running permanent-magnet rotor
  - › Electronically sensorless field-oriented commutated BLDC motor
  - › Differential pressure: 500 hPa up to 900 hPa
  - › Volume flow: 700 l/h up to 2.400 l/h
  - › Electrical power: Max. 130 W
  - › Hydraulic power: 10 W up to 53 W
  - › Coolant temperature: -40°C up to +125°C
  - › Dimensions (without connector and coupling): Outer Ø -82 mm  
Length -89 mm
  - › Weight: < 700 g

## Temperature Sensor Coolant

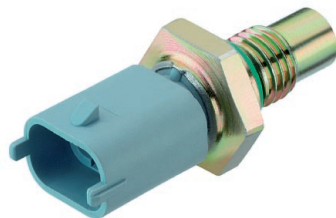

Temperature measurement.

- Benefits**
- › Clip or screw-in design
  - › Wide range of applications
  - › High accuracy
  - › Short response time
  - › Long-term stability
- Technical Information**
- › Engine coolant temperature: -40°C up to +140°C
  - › Accuracy: ± 1°C (at 0°C)
  - › Response time: up to 3 s

## Coolant Flow Control Valve Non-Smart

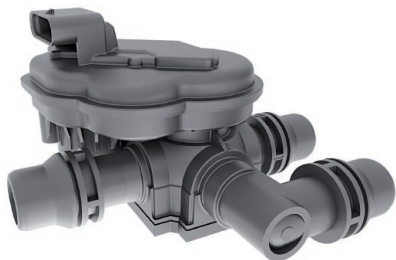

Rotary valve is used for shutting off the coolant flow, switching over coolant circuits, and regulating the coolant flow.

### Benefits

- › Affordable price and full functional range
- › Applicable for ICE, and xEV environment
- › Valve and actuator produced by Continental
- › Modular and flexible design
- › Full movement range, high speed
- › Non-contacting position sensor

### Technical Information

- › Temp. range environment: -40°C up to +125°C
- › Temp. range fluid: -40°C up to +135°C
- › Movement speed: < 2 s over 180° at 13.5 V and RT
- › Tube inner diameter: 16 mm
- › Communication interface: PWM
- › Robust against external magnetic fields

## Coolant Flow Control Valve Smart



Rotary valve is used for shutting off the coolant flow, switching over coolant circuits, and regulating the coolant flow.

### Benefits

- › Affordable price and full functional range
- › Applicable for ICE, and xEV environment
- › Valve and actuator produced by Continental
- › Modular and flexible design
- › Full movement range, high speed
- › Smart (integrated electronics), electrical fail safe

### Technical Information

- › Temp. range environment: -40°C up to +125°C
- › Temp. range fluid: -40°C up to +135°C
- › Movement speed: < 2 s over 180° at 13.5 V and RT
- › Tube inner diameter: 16 mm
- › Communication interface: LIN
- › Robust against external magnetic fields

## 12 V Dual Battery Management System

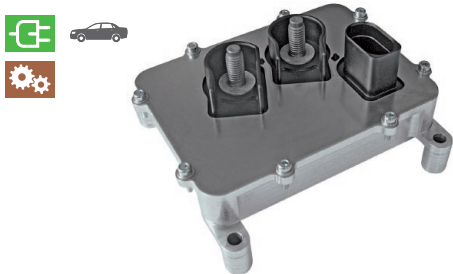

Enables a stable 12 V boardnet by managing the energy flow between two batteries.

- Benefits**
- › Stabilized power net
  - › Extended start-stop (< 20 km/h)
  - › Engine-off coasting
  - › Regeneration
  - › Passive boost
  - › 4% fuel savings on top of start-stop savings
- Technical Information**
- › Power switch: 0.3  $\mu\text{Ohm}$  up to 1  $\mu\text{Ohm}$  (bi-directional or uni-directional)
  - › Current capability: 200 A cont. 1600 A peak
  - › Current measurement: +/-100 A up to +/-1000 A
  - › Optional Battery Management

## 12 V Power Net System



Supports the 12 V boardnet during peak demand, e.g. start-stop.

- Benefits**
- › Second power source (in serial connection)
  - › Supplies additional electric energy for starting and re-cranking, and during engine idle and coasting
  - › High number of load cycles
- Technical Information**
- › Recuperation of electric energy
  - › Very low ohmic energy storage DLC
  - › Energy management and diagnosis, e.g. State of Charge
  - › CAN or LIN communication

## Brushless DC Motor for Brake Applications

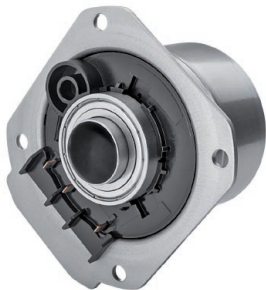

BLDC motor of an innovative braking system.

### Benefits

- › Small package, low weight
- › Low content of rare earth material
- › Symmetrical Back EMF layout
- › Low inertia, high torque, and speed due to high efficient BLDC motor concept

### Technical Information

- › Motor size:  $\varnothing$  80 mm, length 89 mm
- › Motor torque constant: Up to 4.5 Nm at 90 A
- › Performance class: Up to 1,400 W in peak
- › Temperature range:  $-40^{\circ}\text{C}$  up to  $+120^{\circ}\text{C}$
- › Vibration resistant: Up to 40 g
- › Actual load capability: Up to 10 kN



**Doing more. For Clean Power.**  
Powertrain

## Connectivity Solutions

### Connectivity Saves Fuel.

In the past, energy management in vehicles functioned “on demand” - meaning that no matter how intelligently designed the controls within the combustion engine or the electric motor drive were, they still only reacted to the driver’s foot on the pedal.

We are opening up new potential for efficiency with the principle of Connected Energy Management (CEM): By connecting the vehicle with its environment through eHorizon and vehicle-to-X communication, the CEM can factor in the road conditions ahead in time. This helps us gain valuable additional percentage points in vehicle efficiency solely on the basis of software and intelligent, forward-thinking operating strategies. The concept also involves a bidirectional flow of data that other road users benefit from, too. In addition, this innovative approach is useful for all drivetrain configurations in passenger cars and commercial vehicles, from combustion engines to hybrids and electric cars. However, the biggest advantage emerges when it is used in conjunction with electric vehicle technology. Connectivity saves fuel.



## Door Handle Sensor



Sealed module integrating various keyless access functions into a door handle or exterior module.

- Benefits**
- › Easy integration of various functions for PASE system: Capacitive sensor, NFC reader, BLE transceiver, inductive or mechanical switch, LF antenna, lighting, Hall IC
  - › Various communication protocol: Current modulation, voltage output, LIN, CAN.
  - › Fully sealed stand alone module
- Technical Information**
- › Power consumption: <math>< 100 \mu\text{A}</math> for double capacitive sensor
  - › Typical response time: 30 ms
  - › Detection distance: Up to 10 mm, depending (lock/unlock) on door handle type
  - › Antenna inductance: From 100  $\mu\text{H}$  up to 400  $\mu\text{H}$
  - › Temperature range:  $-40^{\circ}\text{C}$  up to  $+85^{\circ}\text{C}$

## Door Handle Sensor with NFC Reader



Sealed module integrating lock/unlock functions (PASE) and vehicle access with smartphone or smart card.

- Benefits**
- › NFC function integrated into stand alone module
  - › Vehicle sharing, fleet management
  - › Back-up to BLE for smartphone as a smart key
  - › Smartphone compatibility with most smartphones
  - › No risk of relay attack due to short detection distance
  - › Vehicle personalization and vehicle status
- Technical Information**
- › NFC protocols ISO/IEC 14443a, ISO/IEC18092:2013
  - › NFC range: up to 40 mm
  - › Dark current: 110  $\mu\text{A}$  for NFC function
  - › Single MCU for capacitive sensors and NFC function
  - › Temperature range:  $-40^{\circ}\text{C}$  up to  $+85^{\circ}\text{C}$
  - › Reaction time:  $\sim 100$  ms
  - › Communication: LIN, CAN

## Door Handle Sensor BLE



Door Handle Sensor with BLE reader.

- Benefits**
- › BLE function integrated into sealed stand alone module
  - › Vehicle sharing, fleet management
  - › Smartphone compatibility with most smartphones
  - › Vehicle personalization and vehicle status

- Technical Information**
- › BLE protocols: 4.2
  - › Single module for capacitive and BLE function
  - › Communication: LIN, CAN
  - › BLE range: 10 m (free field)
  - › Dark current: -50  $\mu$ A for BLE function
  - › BLE scanrate: -100 ms
  - › Temperature range: -40°C up to +85°C

## Easy Trunk Access Sensor



Sealed capacitive sensor module integrated inside a bumper for keyless access to the trunk or sliding doors.

- Benefits**
- › Easy hands-free opening or closing of the trunk or sliding doors
  - › Sensor activated with movement of the leg (no need to press a button or remote control)
  - › Integration of capacitive sensor inside a bumper
  - › Dual electrode set to prevent false activations

- Technical Information**
- › Detection distance: Up to 15 cm (tunable to application)
  - › Quiescent current: 2.5 mA (no low power mode), 250  $\mu$ A (low power mode)
  - › Temperature range: -40°C up to +85°C
  - › LIN, ON/OFF voltage or current output
  - › Vehicle integration guidelines available for specific configurations (trailer hitch, US radars, etc.)

## Combustion Solutions

### Efficiency is Everything.

Fuel is valuable. For this reason, one of our stated goals is to convert it into drive energy as effectively and cleanly as possible.

State-of-the-art injection technology for gasoline and diesel, high-performance engine control units and exhaust gas turbo charging play a key role. However, sensor technology and actuators are becoming key areas of specialization, as they increase control precision to a level that almost no one would have believed possible in series production just a few years ago.

Additionally, combustion can be optimized even further, if we think in terms of whole systems: In a hybrid vehicle with a 48V system, for example, new possibilities open up for optimizing the internal combustion engine.

We utilize these opportunities because as long as combustion engines are around, we believe that it is our job to get the most out of the drive technology - from fuel delivery to optimal atomization. Efficiency is everything.



## Customized Fuel Delivery Module



For 1 or multiple cylinder, 2 and 4 stroke engines in all types of non-automotive applications.

- Benefits**
- › Metal and plastic flanges
  - › Electrically conductive plastics
  - › Fuel level sending units and low levels switches
  - › Integrated jet pump pulls fuel from hard-to-reach areas
- Technical Information**
- › Customized fuel line and electrical connector
  - › Designed and validated to customer specific requirements
  - › Can provide simple assembly as "pump-on-a-stick"

## Diesel Dosing Injector



The dosing system provides a simple and robust technology to deliver liquid diesel fuel into the exhaust path.

- Benefits**
- › Robust approach for Diesel Particle Filter (DPF) and High Efficiency NO<sub>x</sub> Trap (HENT) regeneration
  - › Uses existing injection technologies
  - › Avoidance of oil dilution by post injection leads to longer oil change intervals, greater tolerance of biodiesel, and increased engine durability
  - › Higher degree of flexibility for regeneration timing
- Technical Information**
- › Delivery fuel mass range: 0.1 g/s up to 6 g/s
  - › Accuracy of flow: +/- 7%
  - › Sauter Mean Diameter (SMD): 75 µm up to 150 µm
  - › System pressure: Up to 8.5 bar
  - › Max. control valve temperature: 120°C
  - › Max. spray nozzle temperature: 500°C continuous
  - › System minimum pulse width: 10 ms up to 20 ms

## Diesel Fuel Rail

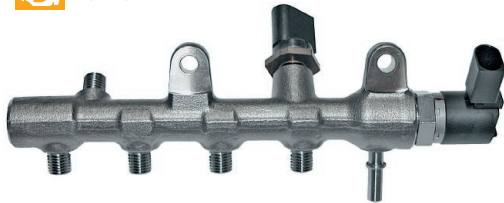

Diesel fuel rail with flexible, proven, and robust design for a high variety of customer specific solutions.

- Benefits**
  - › Weight-reduced design
  - › Modular concept suitable for different engine sizes (3 to 8 cylinder)
- Technical Information**
  - › System pressure: 2,500 bar
  - › Forged rail
  - › Integrated pressure sensor
  - › Option to integrate Pressure Decay Valve (PDV)

## Diesel High Pressure Pump DHP1.1



Next generation of diesel common rail high pressure pump. Platform is basis for future pump applications.

- Benefits**
  - › Digital Inlet Valve (DIV) supports low inlet pressure for high efficiency and low noise
  - › DIV enables efficient fuel supply and highly precise and responsive fuel pressure control
  - › Compact package and light weight
  - › Applicable also for light duty vehicles
- Technical Information**
  - › Pressure: Up to 2,500 bar
  - › Displacement: 0.40 ccm/revolution
  - › Weight: < 3 kg
  - › Length: < 80 mm
  - › Drive: Belt, chain, gear
  - › Rotation: Clockwise, counter clockwise
  - › Radial 1-piston pump: 2 lobes/rev

## Diesel High Pressure Pump DHP2



Common rail pump for passenger cars and light duty vehicles.

- Benefits**
- › Compact package and light weight
  - › High lifetime
  - › Worldwide fuel compatibility
- Technical Information**
- › Pressure: Up to 2,200 bar
  - › Displacement: Up to 0.58 ccm/revolution
  - › Weight: < 4 kg
  - › Length: < 80 mm
  - › Drive: Gear (belt, chain optional)
  - › Rotation: Counter clockwise (clockwise optional)
  - › Radial 2-piston pump: 2 strokes/revolution
  - › Volume metering: Volumetric Control Valve (VCV)

## Diesel High Pressure Pump DHP3



Diesel high pressure pump with small size and light weight supporting common engine sizes.

- Benefits**
- › Smart design for cam drive technology
  - › Reduced leakage behavior
  - › Improved worst-case diesel capabilities
  - › Applicable also for light duty vehicles
  - › Based on proven platform technology.
- Technical Information**
- › Pressure: Up to 2,500 bar
  - › Displacement: 0.23 ccm/stroke
  - › Weight: 800 g
  - › Camshaft with up to 4 lobes possible
  - › Digital Inlet Valve (DIV) supports low inlet pressure for high efficiency and low noise
  - › DIV enables efficient fuel supply and highly precise and responsive fuel pressure control

## Diesel Piezo Common Rail Injector PCRs5



Latest generation of servo-driven piezo common rail injector.

- Benefits**
- › Field-proven piezo technology
  - › High injection precision to meet Euro 6c / US Tier 3 ULEV 70 emission standards
  - › Excellent NVH performance
  - › No permanent leakage enables start-stop capability

- Technical Information**
- › Pressure: Up to 2,500 bar
  - › Minimum quantity:  $\leq 1.0 \text{ mm}^3/\text{stroke}$  for multiple injection patterns
  - › Multiple injection: Up to 7
  - › Minimum hydraulic dwell: 150  $\mu\text{s}$
  - › Total leakage:  $< 30 \text{ ml/min}$  at 2,000 bar (no permanent)
  - › Nozzle hole diameter:  $\geq 90 \mu\text{m}$

## Diesel Pressure Decay Valve PDV 1-25



Latest generation of diesel common rail digital high pressure regulator.

- Benefits**
- › PDV enables pressure control with only one controller for pump inlet and outlet metering - volume control
  - › High efficiency pressure control - only activated for volume decay
  - › Benchmark in controllability and response capability
  - › Compact package and light weight

- Technical Information**
- › Pressure: Up to 2,500 bar
  - › Valve type: Digital currentless closed
  - › Control type: Digital voltage signal
  - › Weight:  $< 220 \text{ g}$
  - › Length:  $< 55 \text{ mm}$  (mounted)

## ECU Bi-Fuel Ready-to-Use EasyU



Scalable, modular ECU for bi-fuel applications. One electronic for gasoline PFI, CNG, LPG.

- Benefits**
- › Mature validated HW and SW platform
  - › Standardized, validated electronic chipset
  - › Engine management control unit or interface box for CNG, LPG
  - › Chassis mounted
  - › Supports up to Euro 5

- Technical Information**
- › Core: Monaco, 80 MHz
  - › Flash size: 1.5 MB
  - › Interfaces: CAN, LIN, K-Line
  - › Injector drivers: 4 PFI + 4 CNG / LPG P&H injector
  - › Driver outputs: 37 + 1 H-bridge + 4 IGBTs
  - › Tightness: IP6K9K
  - › Connector pins: 115

## ECU Diesel Heavy Duty Engines

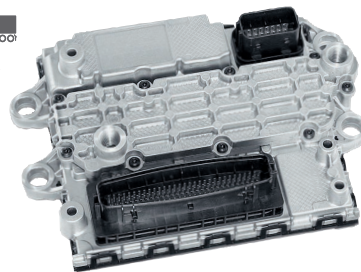

Scalable, modular, validated electronic platform for diesel solenoid medium and heavy duty engines.

- Benefits**
- › Diesel engine management for amplified common rail and pump-line-nozzle and other solenoid injection systems
  - › On-engine mounted with damping elements
  - › Fulfills current emission requirements (EPA 2010+, Euro VI+, combined with SCR)

- Technical Information**
- › Core: TC1797
  - › Flash size: 4 MB
  - › Interfaces: CAN
  - › Injector drivers: 12
  - › Driver outputs: 21 + 1 H-bridge
  - › Tightness: IP69K, IP67
  - › Connector pins: 141

## ECU Diesel Piezo Common Rail

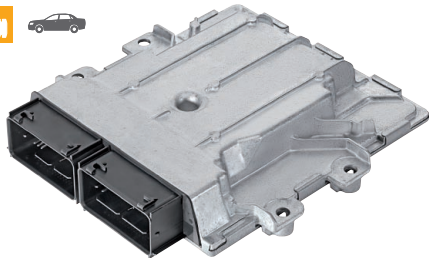

Scalable, modular, validated electronic, and SW platform with standardized chipset for various engines.

### Benefits

- › Controls piezo servo drive injectors, high pressure pump, and SCR subsystem (sensors and actuators)
- › Supports Euro 6c

### Technical Information

- › Core: Multicore architecture Tricore and Power PC
- › Flash size: 2.5 MB up to 8 MB
- › Interfaces: CAN, LIN, FlexRay, SENT, PSI5
- › Injector drivers: 3 up to 8 piezo
- › Driver outputs: High-/low-side, up to 5 H-bridges
- › Housing: Aluminum or magnesium
- › Connector pins: Scalable up to 336
- › ISO 26262, AUTOSAR 4.2

## ECU Diesel Platform for Commercial Vehicles

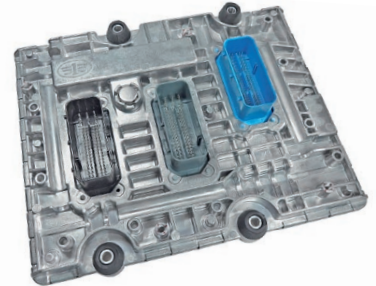

Scalable, modular electronic platform for diesel solenoid medium and heavy duty engines.

### Benefits

- › Integrated after-treatment functions
- › Standardized, scalable, and modular electronics
- › On-engine mounted with dampers
- › 12/24 V universal voltage
- › Supports Euro VI and Euro VI+

### Technical Information

- › Core: Multicore TC297
- › Flash size: 8 MB
- › Interfaces: CAN, CAN FD, LIN
- › Injector drivers: Up to 6 cylinders, 3 banks
- › Driver outputs: 59 + 3 H-bridges
- › Tightness: IP6K9K
- › Connector pins: 248

## ECU Gasoline Port Fuel Injection

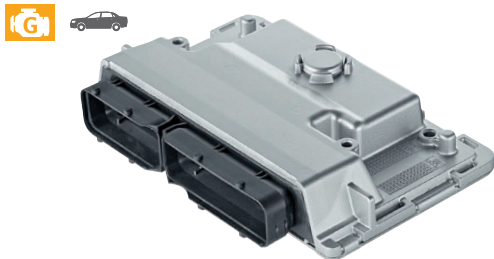

Scalable, modular, validated electronic, and SW platform with standardized chipset for various PFI engines.

- Benefits**
- > One flexible design for all Euro 6 PFI engines
  - > 3/4 cyl engine feed with gasoline, flex-fuel (ethanol), GPL
  - > Chassis-mounted, engine bay

- Technical Information**
- > Core: TC275, 200 MHz
  - > Flash size: 4 MB
  - > Interfaces: CAN, CAN-WakeUP, LIN, SENT
  - > Injector drivers: 4 PFI, CNG, E100
  - > Driver outputs: 38, 3 H-bridges
  - > Tightness: IP6K9K
  - > Connector pins: 160

## ECU Gasoline Port Fuel Injection Ready-to-Use EasyU



Scalable, modular electronics, and SW for various engines. Configurable off-the-shelf engine control unit.

- Benefits**
- > Mature validated HW and SW platform for various vehicle configurations: EOBD, VVT, EGR, turbo, VIM, PORT, and start-stop
  - > Fast time to market
  - > Supports Euro 6

- Technical Information**
- > Core: Monaco/Andorra
  - > Flash size: 1, 1.5, 4 MB
  - > Interfaces: CAN, CAN-WakeUP, LIN, SENT
  - > Ignition driver: Internal IGBT or external
  - > Injection drivers: 4 PFI
  - > Tightness: IP6K9K, IP67
  - > Connector pins: 128
  - > Housing temp. range: -40°C up to +105°C
  - > Binary and linear O<sub>2</sub> sensor

## ECU Gasoline SDI and TCU

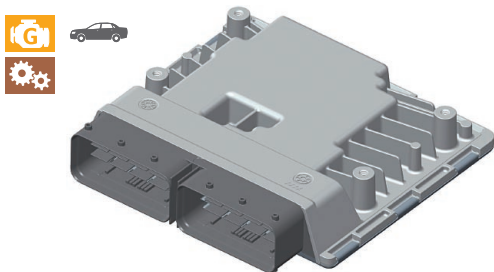

Scalable, modular, validated electronic, and SW platform with standardized chipset for various engines.

### Benefits

- › Combined control unit for gasoline solenoid direct injection and transmission control
- › FF 8AT automatic transmission control with 6AT and CVT functional capability
- › Chassis-mounted
- › Supports Euro 6 / 6c

### Technical Information

- › Core: EMS TC277, 200 MHz;  
TMS TC275, 200 MHz
- › Flash size: EMS 4 MB; TMS 4 MB
- › Interfaces: CAN, CAN FD, LIN
- › Injector drivers: 4 SDI
- › Driver outputs: 48 + 6 H-bridges + 8 linear solenoids
- › Tightness: IP69K
- › Connector pins: 238

## ECU Gasoline SDI Ready-to-Use EasyU

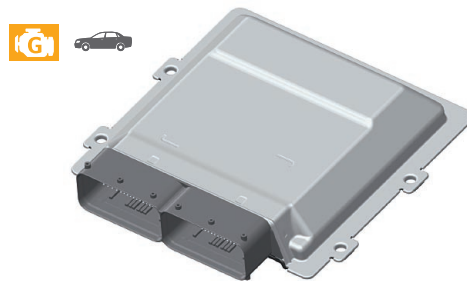

Scalable, modular electronics, and SW for various engines. Configurable off-the-shelf engine control unit.

### Benefits

- › Mature validated HW, SW, and calibration platform
- › Standardized electronic chipset
- › HW, SW basic configuration ready for production
- › Fast time to market
- › Supports Euro 6 / 6c

### Technical Information

- › Core: TC277, 200 MHz
- › Flash size: 4 MB
- › Interfaces: CAN, CAN FD, CAN-WakeUP
- › Injector drivers: 4 SDI + 4 PFI
- › Driver outputs: 34 + 4 H-bridges
- › Tightness: IP6K9K
- › Connector pins: 196
- › Housing temp. range: -40°C up to +105°C

## ECU Gasoline Solenoid Direct Injection

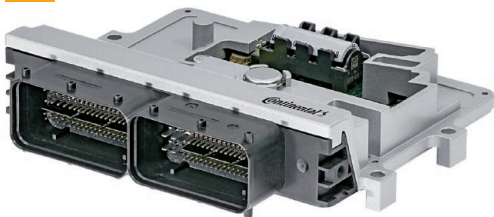

Scalable, modular and validated electronic, and SW platform with standardized chipset for various SDI engines.

- Benefits**
- › ECU with multiple options: Variable valve lift control, lambda control LIN/BIN, turbocharger
  - › Encryption for hardware protection (SHE)
  - › Supports Euro 6c
- Technical Information**
- › Core: Tricore and Power PC multicore architecture
  - › Flash size: 2.5 MB up to 16 MB
  - › Interfaces: CAN FD, LIN, FlexRay, SENT, PSI5, Ethernet
  - › Injector drivers: 3 up to 6 SDI/PFI
  - › Driver outputs: High-/low-side, up to 6 H-bridges
  - › Tightness: IP6K9K
  - › Connector pins: Scalable up to 336
  - › ISO 26262, AUTOSAR 4.2

## ECU M3B (Air Module)



For 1 and 2 cylinder, 2 and 4 stroke engines up to 1,000 cc in motorcycles, scooters, lawn mowers, generator sets.

- Benefits**
- › ECU with integr. electronic throttle body and sensors
  - › Cost optimization and easy mounting
  - › Throttle body size: Ø 26 up to 50 mm
  - › Versatile configuration
- Technical Information**
- › Integr. TMAP sensor, ETC controller, monitoring unit
  - › 32 bit microcontroller, 40 MHz
  - › 1 MB ROM (flash), 36 KB RAM
  - › IP67 and IP6K9K (high pressure cleaning)
  - › Input and output with full diagnostics and protection
  - › Operating temperature range: -40°C up to +85°C
  - › 32 pin connector with spares for vehicle functions
  - › CAN interface for diagnostics and reprogramming

## ECU M3C

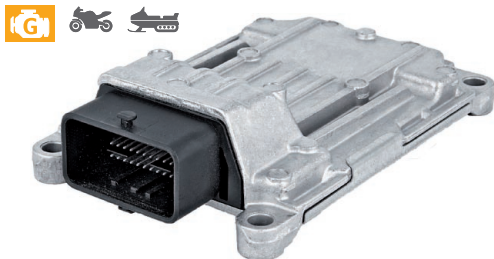

For 1 and 2 cyl., 2 and 4 stroke engines up to 1,100 cc in medium to high end motorcycles, scooters, ATV, snowmobiles.

- Benefits**
- › Extended I/O for improved functionality
  - › Enhanced timer module and control capability
  - › Robust mechanics with aluminum casing
- Technical Information**
- › 16 bit microcontroller, 16 MHz
  - › 256 KB ROM (flash), 16 KB RAM
  - › IP67 and IP6K9K (high pressure cleaning)
  - › Two knock sensor inputs
  - › Input and output with full diagnostics and protection
  - › Operating temperature range: -40°C up to +85°C
  - › 48 pin connector with spares for extended functions
  - › CAN interface for diagnostics and reprogramming

## ECU M4D Ride-By-Wire



For 1 up to 4 cylinder, 2 and 4 stroke engines running up to 16,000 rpm in high end motorcycles, scooters, ATV, etc.

- Benefits**
- › Drives simultaneously up to 2 individual electrical throttle bodies and 2 DC-motor actuators
  - › Direct-drives up to 4 ignition coils (option: smart coils)
  - › Designed to meet Euro 5 with EOBD
- Technical Information**
- › 32 bit microcontroller, 120 MHz
  - › 2 MB ROM (flash), 128 KB RAM
  - › IP67 and IP6K9K (high pressure cleaning)
  - › Separate safety monitoring unit for ETC system
  - › Operating temperature range: -40°C up to +85°C
  - › Single pocket 120-pins CMX connector
  - › Dual CAN and LIN interfaces
  - › 2 knock inputs, 2 linear + 2 binary O<sub>2</sub> sensors
  - › ISO 26262 compliant

## ECU M4L/XE Air Module



For 1 cylinder, 4 stroke engines from 50 cc up to 250 cc in light motorcycles, scooters, lawn mowers, generator sets.

### Benefits

- › ECU with integrated throttle body and sensors
- › Very compact size and easy mounting
- › Versatile configuration: Connector position, engine mounting interface, accelerator cable etc.
- › Euro 5, China stage 4, Bharat stage 6, OBDII

### Technical Information

- › Throttle body size from Ø 16 mm up to 32 mm
- › Integrated Throttle Position Sensor, Temperature Manifold Air Pressure, and Idle Speed Stepper
- › 32 bit microcontroller, 32 MHz, 256 KB Flash
- › IP66 and IP6K9K (high pressure cleaning)
- › Operating temperature range: - 40°C up to +85°C
- › 18 pin connector with spares for vehicle functions

## EMS3 Engine Management System Platform



Electronic and SW EMS platform for powertrain: Gasoline, diesel, commercial vehicle. Scalable for worldwide markets.

### Benefits

- › For Euro 6+ diesel/ gasoline drivetrain and electrical drive: PFI, SDI, PCR, Flex Fuel, CNG
- › Supports various engine sensors and actuators
- › Improved power consumption and higher function integration

### Technical Information

- › Up to 6 cores and 16 MB flash size
- › Interfaces: CAN FD, LIN, FlexRay, SENT, PSI5, Ethernet
- › Generic Timer Module V3.1 (GTM)
- › Injector drivers: 2 piezo up to 8 piezo, solenoid
- › Driver outputs: 16 up to 60, flexible high-/low-side
- › Connector pins: Up to 196 (300 in combination)
- › ISO 26262, PowerSAR®: AUTOSAR 4.2, multicore freely distributable

## Gasoline Deka 10 Port Fuel Injector



Features high flow range and reduced packaging, also for twin/dual port engines, and non-automotive applications.

- Benefits**
- › Low minimum fueling with high linear performance and low voltage sensitivity
  - › Improved leakage and extended operating pressures
  - › Extra short length 23 mm available

- Technical Information**
- › System pressure: 4 bar (max. 12 bar)
  - › Static flow rate: 0.50 g/s up to 10.0 g/s
  - › Linear flow range: 15:1
  - › Tip leakage: <math>< 1.8 \mu\text{l}/\text{min}</math> (3 bar, Exxsol), <math>< 0.5 \mu\text{l}/\text{min}</math> (Partial Zero-Emission Vehicle (PZEV) option available)
  - › Fuel compatibility: Gasoline and flex fuel (up to E100/M30)

## Gasoline Deka 7/9 Port Fuel Injector



Flexible body, tip and spray configurations. Deka 9 with high flow range for turbocharged engines.

- Benefits**
- › Various spray options and packaging configurations
  - › Low minimum fueling with high linear performance and low voltage sensitivity
  - › Improved leakage capabilities and extended operating pressures

- Technical Information**
- › System pressure: 4 bar (max. 9 bar)
  - › Static flow rate: 0.95 up to 6.0 g/s (Deka 7), 0.5 up to 8.0 g/s (Deka 9)
  - › Linear flow range: 10:1
  - › Tip leakage Deka 9: <math>< 1.8 \mu\text{l}/\text{min}</math> (3 bar, Exxsol), <math>< 0.5 \mu\text{l}/\text{min}</math> enhanced for Partial Zero Emission Vehicle (PZEV) application
  - › Fuel compatibility: Gasoline + flex fuel (up to E100)

## Gasoline DI XL3.1 Solenoid Injector



Gasoline Direct Injection (GDI) injector for natural aspirated and turbocharged engines.

### Benefits

- › Improved linear flow range for high turbocharged engines, suitable for side and central injection
- › High flexibility of spray characteristics
- › Low temperature capable O-rings
- › Enhanced nozzle geometry for Euro 6c spray performance
- › Worldwide fuel compatibility

### Technical Information

- › Pressure: Up to 250 bar
- › Static flow range: Up to 20 g/s
- › Minimum dynamic flow: -2.0 mg/stroke at 250 bar with controlled solenoid injection (COSI)
- › Multiple injection: < 800  $\mu$ s hydr. dwell time
- › Multi-stream technology: Max. 7 holes
- › Nozzle hole drilling techn.:  $\mu$ EDM or Fs-Laser

## Gasoline DI XL5 Solenoid Injector



For natural aspirated and downsized turbocharged engines and future exhaust emission legislation.

### Benefits

- › Euro 6d capable (WLTP, RDE)
- › Excellent mixture preparation and combustion
- › Modular design for installation with small packaging requirements
- › Worldwide fuel compatibility

### Technical Information

- › System pressure: Up to 350 bar
- › Minimum dynamic flow: 1.5 mg/stroke at 200 bar with controlled solenoid injection functionality HW and SW (COSI 2)
- › Hydraulic dwell time: 800  $\mu$ s
- › Multi-stream technology: Max. 7 holes
- › Nozzle hole drilling technology:  $\mu$ EDM or Fs-Laser

## Gasoline Fuel Rail Assembly



Gasoline fuel rail assembly for low and high pressure applications.

### Benefits

- › GDI: Modular rail portfolio to support customer specific solutions clamped and suspended
- › Weight optimized rail architecture - up to 10% improvement
- › Pressure sensors optional
- › PFI: Customer specific solutions available

### Technical Information

- › GDI: Fuel rail assembly up to 350 bar
- › Accurate injector orientation for optimal spray target
- › PFI: Plastic and stainless steel fuel rails
- › Fuel rail assembly up to 9 bar
- › Optional internal damper
- › E100 capability including SVS injection

## Gasoline High Pressure Pump GHP2.5 DI/PFI



Modular pump with an operational pressure up to 350 bar to maintain the future injection pressure levels.

### Benefits

- › Increased robustness level
- › Toolbox for balance of flow delivery vs. load and torque
- › Low parasitic losses inside pump
- › Low operating noise level
- › Dual system (DI/PFI) feeding via HP Pump

### Technical Information

- › System pressure: Up to 350 bar
- › Engine speed: Up to 7,500 1/min
- › Max. flow (theoretical): Up to 1,005 cc/rev, 1,41 cc/rev (HF)
- › Piston diameter: 8 mm, 10 mm (HF)
- › Fuel: Standard fuels compatible, optional bad fuel version

## Gasoline High Pressure Pump GHP2.5



GHP2.5

GHP2.5 High Flow

Modular pump with an operational pressure up to 350 bar to maintain the future injection pressure levels.

### Benefits

- › Increased robustness level
- › Toolbox for balance of flow delivery vs. load and torque
- › Low parasitic losses inside pump
- › Low operating noise level
- › Flexible packaging

### Technical Information

- › System pressure: Up to 350 bar
- › Engine speed: Up to 7,500 1/min
- › Max. flow (theoretical): Up to 1.005 cc/rev, 1.41 cc/rev (HF)
- › Piston diameter: 8 mm, 10 mm (HF)
- › Fuel: Standard fuels compatible, optional bad fuel version

## Gasoline Turbocharger with Aluminum Turbine Housing

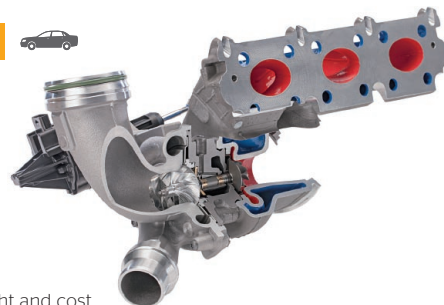

Weight and cost reduced turbocharger with thermal advantages.

### Benefits

- › Cost reduction by lower material cost and elimination of heat shields
- › Facilitates stoichiometric combustion at rated power
- › Prevents oil coaking during heat soak
- › Ensures faster heat-up of water and oil
- › Water-cooled aluminum turbine housing

### Technical Information

- › Application specific wheel design for cutting edge thermodynamics
- › Milled compressor wheel
- › Exhaust temperature up to 1050°C
- › Rotational speed up to 580 m/s
- › Pneumatic or electric waste-gate actuation
- › Both rotational directions available

## Gasoline Turbocharger with Steel Turbine Housing

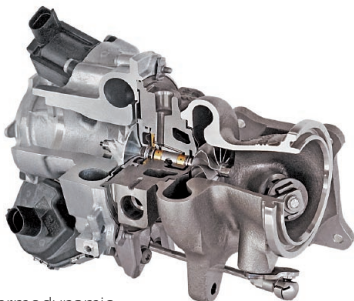

Benchmark thermodynamic performance. Robust and reliable design.

### Benefits

- › Patented turbine/center housing connection with tie-rod screws
- › RAAX™ turbine technology for best transient response
- › Application specific wheel design for cutting edge thermodynamics, drivability, and best fuel economy
- › Highly effective sealing system

### Technical Information

- › Water-cooled bearing housing
- › Milled compressor wheel
- › Exhaust temperature up to 1050°C
- › Rotational speed up to 580 m/s
- › Pneumatic or electric waste-gate actuation
- › Optional electrical compressor bypass valve and electrical wastegate actuator from Continental

## Gasoline Turbocharger with VRAAX™ Turbine Technology



VRAAX™ turbine technology with variable inlet guide vanes for improved time to torque.

### Benefits

- › Robust and reliable design, enhanced wear behavior
- › Benchmark hysteresis for excellent controllability
- › Low inertia for superior transient response
- › Cartridge concept for improved thermomechanical characteristics
- › Compensates impact of reduced scavenging

### Technical Information

- › Variable geometry turbine with 3D vane shape
- › Milled compressor wheel
- › Rotational speed up to 580 m/s
- › Bearing housing with or without water cooling
- › T3 up to 950°C / 980°C
- › Pneumatic or electric wastegate actuation

## Ignition Coil



For mopeds, scooters, light motorcycles, lawn mowers, electric power generators.

- Benefits**
- › Small size inductive coil
  - › High voltage diode integrated
  - › Standard high voltage connector
  - › Standard primary connector
- Technical Information**
- › Nominal voltage supply: 14 V + 0.5 V
  - › Maximum primary current: 3.3 A
  - › Dwell time: < 6 ms
  - › Arc duration (1,000 V Zener): 0.5 ms + 0.2 ms
  - › High voltage suppressor diode
  - › Recomm. cable size (mm<sup>2</sup>): 2.0 up to 2.5
  - › Recomm. cable overall Ø (mm2): 2.5 up to 3.5

## Oxygen Sensor



For 1 or multiple cylinder, 2 and 4 stroke engines in all types of non-automotive applications.

- Benefits**
- › Specifically developed for 2-wheeler environments
  - › A hermetic structure which uses injection current pumping method against water splash
  - › Resistant to water droplets
  - › Vibration resistance
- Technical Information**
- › Lead wire: 4 wire
  - › Cable length: 500 mm
  - › Body length: 35 mm
  - › Thread size: M12
  - › Reference air: Self pumping
  - › Heater resistance: 8.1 ohm

## Active Purge Pump



Generates the flow of fuel vapors from an evaporative emission canister to the manifold of limited vacuum engines.

### Benefits

- › HC purging is independent from manifold vacuum
- › OBD monitoring for HC evaporative leak detection
- › Low power consumption (-30 W)
- › Compact size for vehicle packaging

### Technical Information

- › Radial pump with integrated electronics
- › Purge flow: 50 slpm at 10 kPa at 10.5 V, RT, dry air
- › Operating temp.: -40°C up to +120°C
- › Brushless DC motor: -30 W
- › Feedback for speed and torque

## Air Control Valve Economy Line S11.1



Intake air pressure control for diesel combustion engines. Supports EGR and particle filter regeneration on diesel engines. Full plastic design concept.

### Benefits

- › Low cost performance, full functional range
- › Low weight, small package
- › Good crash behavior
- › Capable for turbo applications

### Technical Information

- › Temperature range: -40°C up to +140°C
- › Response time (typ.): 110 ms (13.5 V, RT)
- › Pressure range: Up to 3.5 bar peak
- › Leakage (at stop): < 2.8 kg/h (TP Ø 48 mm)
- › TP Ø range: 40 mm up to 57 mm

## Air Control Valve - Performance Line S8.6



Intake air flow and pressure control on combustion engines. Supports EGR and particle filter regeneration.

- Benefits**
- › Modular capable for 12 V and 24 V systems
  - › Capable for big TP diameters - high flow
  - › Capable for turbo and supercharged applications

- Technical Information**
- › Temperature range: -40°C up to +140°C
  - › Response time (typ.): 90 ms (13.5 V, RT)
  - › Pressure range: Up to 3.5 bar peak
  - › TP diameter range: 57 mm up to 100 mm
  - › Signal output: Analog 5 V

## Air Control Valve 12 - Modular Performance

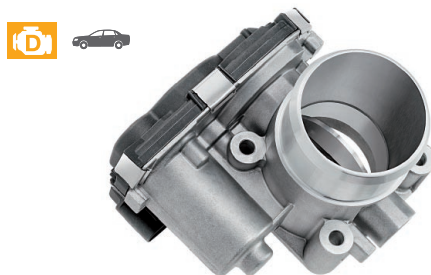

Intake air flow and pressure control on combustion engines. Supports EGR and particle filter regeneration.

- Benefits**
- › Modular design concept, low weight, small package
  - › High torque, fast response
  - › Low leakage
  - › Capable for turbo- and supercharged applications

- Technical Information**
- › Temperature range: -40°C up to 140°C  
180°C for high temperature
  - › Response time (typ.): 90 ms (13.5V, RT)
  - › Pressure range: up to 3.5 bar peak
  - › Leakage (at stop): < 2.5 kg/h (TP Ø52 mm),  
< 3.5 kg/h for high temperature
  - › TP diameter range: 40 up to 95 mm
  - › Signal output: Analog 5 V or digital SENT
  - › Weight: 490 g (TP Ø48 mm with optimized housing)

## Air Control Valve 12 - Modular Performance



Water Cooled

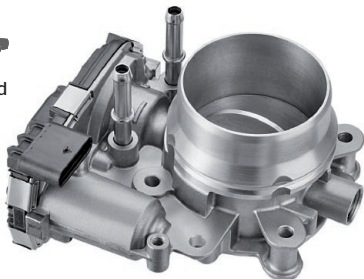

Intake air flow and pressure control on combustion engines. Supports EGR and particle filter regeneration on diesel applications.

- Benefits**
- › Modular design concept
  - › High torque, fast response
  - › Low weight, very small package
  - › Low leakage
  - › Capable for turbo- and supercharged applications
  - › Used for very high temperature applications

- Technical Information**
- › Temperature range: -40°C up to 230°C
  - › Response time (typ.): 90 ms (13.5V, RT)
  - › Pressure range: Up to 3.5 bar peak
  - › Leakage (at stop): < 3.5 kg/h (TP Ø 52 mm)
  - › TP diameter range: 40 up to 95 mm
  - › Signal output: Analog 5 V or digital SENT

## Brushless DC Drives High Efficiency



Best performance motors to reasonable prices for different use out of a scalable, modular concept.

- Benefits**
- › High efficiency brushless DC drives for use in double clutch, AWD-disconnect, oil pumps etc.
  - › Small package, low weight, low inertia due to high copperwire filling rate
  - › Low content of rare earth material
  - › High torque as well as high speed capability within the modular concept

- Technical Information**
- › Different performance classes: 50 W up to 900 W
  - › Variation of diameter, length and windings depending on customers' needs
  - › Temperature range: -40°C up to +140°C

## Canister Purge Solenoid CPS6



The Canister Purge Solenoid controls hydrocarbon vapors from the canister to the intake manifold.

### Benefits

- › Higher flow than competitive valves
- › Linear flow curve and fast response
- › Sonic nozzle flow control
- › Integrated particle trap to control contamination
- › Integrated noise attenuation volume

### Technical Information

- › Flow at >30 kPa: 110 SLPM (2.3 g/s, 7.9 kg/h)
- › Operating voltage: 9 V up to 16 V (13.5 V optimal)
- › Coil resistance: 21 Ohms
- › OBD leakage (6.7 kPa vacuum on canister port): < 3.0 SCCM
- › Operating temp.: -25°C up to +125°C
- › Frequency: 5 Hz up to 32 Hz (10 Hz recommended)

## Digital Linear Actuator Compact Size - Gen VII



Idle airflow control for two-wheeler and small engines.

### Benefits

- › Accurate and stable idle air control
- › Various gas (air) flow curve can be achieved
- › Light-weighted and small-sized robust design
- › High resolution linear positioning against load
- › Two packagings for different integration options

### Technical Information

- › Operating voltage: 7.5 V up to 14 V
- › Inductance/winding: 20.7 mH
- › Resistance/winding: 53 Ohms
- › Resolution: 0.042 mm/step (full step mode)
- › Total travel (typ.): 8.5 mm (204 steps)
- › Operating temp.: -30°C up to +110°C
- › Airflow control: Up to 41.8 kg/hr at  $\Delta P = 600$  hPa

## Digital Linear Actuator Standard Size - Gen I

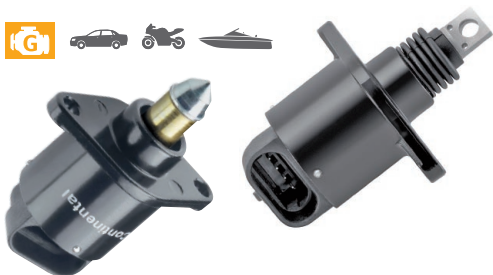

Accurate and precise gas/airflow.  
Linear position control against external load.

- Benefits**
- › Accurate and stable idle air control
  - › Various gas (air) flow curve can be achieved
  - › High accuracy under severe conditions
  - › Proven reliability and long durability
  - › High resolution linear positioning against load

- Technical Information**
- › Operating voltage: 12 V (7.5 V - 14 V)
  - › Resistance per winding: 53 Ohms
  - › Linear resolution: 0.042 mm/full step
  - › Total travel (typical): 8.5 mm (204 steps)
  - › Operating temperature: -40°C up to +125°C
  - › Vibration capability: Up to 40 G
  - › Life time durability: 500 hours
  - › Weight: Around 110 g

## Digital Linear Actuator Standard Size - Gen II

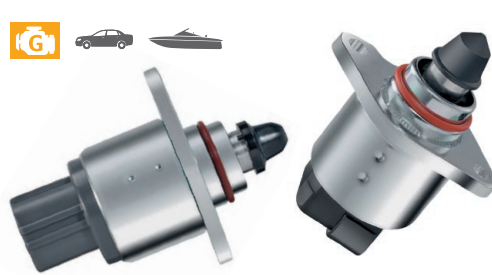

Accurate and precise gas/airflow.  
Linear position control against external load.

- Benefits**
- › Accurate and stable idle air control
  - › Various gas (air) flow curve can be achieved
  - › High accuracy under severe conditions
  - › Proven reliability and long durability
  - › High resolution linear positioning against load

- Technical Information**
- › Operating voltage: 12 V (7.5 V - 14 V)
  - › Resistance per winding: 48 Ohms
  - › Linear resolution: 0.042 mm/full step
  - › Total travel (typical): 8.5 mm (204 steps)
  - › Operating temperature: -40°C up to +125°C
  - › Vibration capability: Up to 40 G
  - › Life time durability: Up to 2,000 hours
  - › Weight: Around 90 g

## Digital Linear Actuator Standard Size - Gen V



Accurate and precise gas/air flow.  
Linear position control against external load.

- Benefits**
- › Accurate and stable idle air control
  - › Various gas (air) flow curve can be achieved
  - › High accuracy under severe conditions
  - › Proven reliability and long durability
  - › Plastic sleeve gives lighter weight
- Technical Information**
- › Operating voltage: 12 V (7.5 V - 14 V)
  - › Linear resolution: 0.042 mm/full step
  - › Total travel (typical): 8.5 mm (204 steps)
  - › Vibration capability: Up to 35 G
  - › Life time durability: Up to 1,000 hours
  - › Weight: 45 g up to 53 g

## Electrical Compressor Bypass Valve



Compressor surge prevention and turbocharger lag reduction by opening a bypass for the compressor.

- Benefits**
- › Electromagnetic on-off solenoid
  - › Improved performance and size
  - › No vacuum lines, tank, or vacuum control valve needed
  - › Fast actuation
  - › Mounted directly on turbocharger or air duct
- Technical Information**
- › Nom. operating voltage: 12 V
  - › Response: < 50 ms at 20°C; 13.5 V
  - › Operation (gas) temp.: -40°C up to +180°C  
short term (30 min.): +200°C
  - › Ambient temperature: -40°C up to +150°C
  - › Storage temperature: -40°C up to +200°C
  - › Travel: ≥ 5 mm; Poppet Ø 26 mm

## Electrical Exhaust Gas Recirculation Valve



Controls the amount of recirculated exhaust gas to reduce  $\text{NO}_x$  emissions and fuel consumption.

- Benefits**
- › Electric actuation has faster response and more control than conventional vacuum systems
  - › Eliminates vacuum regulator and connecting hoses
  - › Can be tailored to customer flow requirements
- Technical Information**
- › Current consumption at max. flow: 1.0 A at 20°C
  - › Nominal operating voltage: 12 V<sub>DC</sub>
  - › Max current consumption: 1.5 A
  - › Nominal coil resistance: 8.0 Ohms at 20°C
  - › Nominal operating frequency: 90 Hz up to 175 Hz
  - › Position sensor supply voltage: 5 V<sub>DC</sub>
  - › Response time (total stroke): < 50 ms at 20°C, 13.5 V<sub>DC</sub>

## Electronic Throttle Control 11.2 - Economy Line



Torque / load control on gasoline combustion engines. Supports idle speed, cruise, and traction control.

- Benefits**
- › Low weight, small package
  - › Low leakage
  - › Capable for turbo- and supercharged applications
- Technical Information**
- › Temperature range: -40°C up to +140°C
  - › Pressure range: Up to 2.5 bar peak
  - › Response time (typ.): 100 ms (13.5 V, RT)
  - › Leakage: < 2.5 kg/h (TP Ø 52 mm)
  - › TP Ø range: 40 up to 68 mm

## Electronic Throttle Control ETC 12 – Modular Perform.

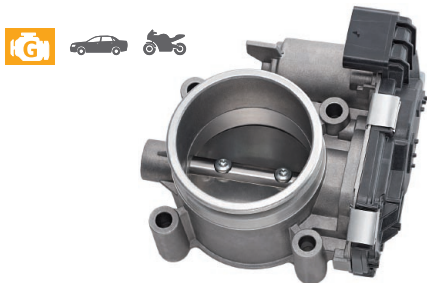

Torque/load control on gasoline combustion engines.  
Supports idle speed, cruise, and traction control.

### Benefits

- › High performance throttle body actuator
- › Modular design concept
- › Low weight, very small package
- › Low leakage, spherical bore optional
- › Capable for turbo and supercharged applications

### Technical Information

- › Temperature range: -40°C up to +140°C  
180°C for high temperature
- › Response time (typ.): 90 ms (13.5 V, RT)
- › Pressure range: Up to 3 bar peak
- › Leakage (at stop): < 2.5 kg/h (TP Ø 52 mm),  
< 3.5 kg/h for high temperature
- › TP diameter range: 40 mm up to 95 mm
- › Signal output: Analog 5 V or digital SENT

## Electronic Throttle Control 13 – Economy Line



Torque / load control on gasoline combustion engines.  
Supports idle speed, cruise, and traction control.

### Benefits

- › Modular design concept
- › Lowest weight with hybrid housing, very small package
- › Low leakage as regular aluminum housing
- › Capable for turbo applications

### Technical Information

- › Temperature range: -40°C up to +140°C
- › Response time (typ.): 100 ms (13.5 V, RT)
- › Pressure range: Up to 2.5 bar peak
- › Leakage (at stop): < 2.5 kg/h (TP Ø 44 mm)
- › TP Ø range: 40 up to 57 mm

## Electrical Wastegate Actuator

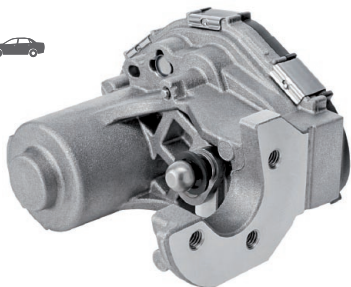

Performing waste-gate adjustment to optimize functional application and reduce fuel consumption.

- Benefits**
- › Continuous adjustment of external application using rotating output shaft
  - › Ideal for use in turbocharger applications
  - › Option: Default position
  - › Permanent feedback signal (contactless)
- Technical Information**
- › Max. external load without return function: 92 Ncm
  - › Max. continuous holding torque without return function at 140°C: 144 Ncm
  - › Holding torque capability at 140°C: 420 Ncm
  - › Response time less than: 100 ms/80° angle at 160°C
  - › Operation temperature: -40°C up to +160°C

## Exhaust Control Valve High Pressure



Helps to reduce emissions of NO<sub>x</sub> and fuel consumption in gasoline and diesel engines in HP EGR loop.

- Benefits**
- › Balanced rotary throttle principle for EGR control
  - › Contactless MR Sensor, flexible output
  - › Provides accurate low flow precision
  - › High flow EGR with low gas pressure drop
  - › Fits high temperature and pressure pulsations
- Technical Information**
- › Torque at flap: 230 Ncm
  - › Response time (85%): < 80 ms
  - › Nominal supply voltage: 12 V<sub>DC</sub> or 24 V<sub>DC</sub>
  - › Position sensor supply voltage: 5 V<sub>DC</sub>
  - › Maximum flow: Up to 190 kg/h at 50 hPa
  - › Exhaust temperature: Up to 700°C

## Exhaust Control Valve Linear



Helps to reduce emissions of  $\text{NO}_x$  and fuel consumption in gasoline and diesel engines.

- Benefits**
- > Linear technology (direct position measurement)
  - > Reduced friction and short response time
  - > Low valve seat leakage
  - > Compact design
  - > Opening force up to 500 N
  - > Mechanical + electrical interfaces can be customized

- Technical Information**
- > Nominal supply voltage: 12  $V_{DC}$
  - > Pos. sens. supply voltage: 5.0  $V_{DC}$
  - > Exhaust gas temperature: >500°C with adequate cooling
  - > Max. typical flow: 120 kg/h at dP 100 hPa (single poppet design)
  - > Response time (t85): ≤100 ms

## Exhaust Control Valve Low Pressure

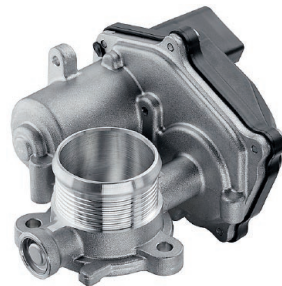

Helps to reduce emissions of  $\text{NO}_x$  and fuel consumption in gasoline and diesel engines in LP EGR loop.

- Benefits**
- > High flow LP EGR valve with small pressure drop
  - > Non-contacting sensor, flexible output, not sensitive against magnetic fields
  - > Compact, light-weighted size
  - > Adapted to corrosion requirement for LP EGR path

- Technical Information**
- > Response time (t90): < 90 ms
  - > Nominal supply voltage: 12  $V_{DC}$
  - > Position sensor supply voltage: 5  $V_{DC}$
  - > Maximum flow (at dP 20 hPa): 245 kg/h
  - > Internal leakage (at dP 600 hPa): ≤ 3 kg/h
  - > Max. differential press. over flap: 300 kPa
  - > Exhaust gas temperature: 100°C up to 200°C

## Fluid Sensor Flex Fuel Ethanol

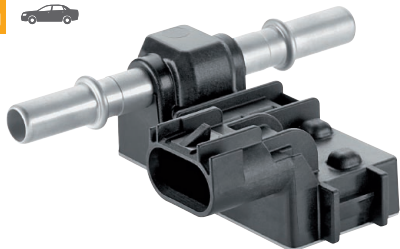

Detects ethanol concentration in gasoline / ethanol fuel mixture.

### Benefits

- > Highly accurate prediction of ethanol concentration
- > Enables ethanol detection before injection / combustion
- > Outputs ethanol concentration and fuel temperature within 250 ms after start-up
- > Self diagnostic capability

### Technical Information

- > Measurement principle: Capacitive (0% up to 100% ethanol content)
- > Accuracy: +/- 5% ethanol concentration
- > Pressure range: <10 bar (145 psi)
- > Fuel temp. range: -40°C up to +90°C
- > Environmental temp.: -40°C up to +150°C

## Fluid Sensor - Oil Level Passive Electrothermic



Sensor monitors correct engine oil level to avoid overfill or underfill during driving or at key-on.

### Benefits

- > Overfill and low level indication
- > Absolute measurement of oil level in static and dynamic conditions
- > Replacement of oil dipstick
- > Different mounting positions
- > Temperature measurement optional

### Technical Information

- > Measuring principle: Thermo-resistive heated wire
- > Measuring range: 100 mm between min. and max.
- > Accuracy approx.: +/- 3 mm
- > First measurement: Available 0.6 s after key-on
- > Measuring interval: > 10 s
- > Operating temp.: -40°C up to +160°C

## Fluid Sensor Oil Level Switch



Level switch to monitor engine oil level below minimum threshold.

- Benefits**
- › Low oil level detection
  - › Different connectors possible
  - › Simple on/off output
  - › Market proven
- Technical Information**
- › Measuring principle: Magnetic reed switch
  - › Different switch heights possible
  - › Normally on (switch closed)
  - › Tolerance: +/- 1 mm

## Fluid Sensor – Oil Level Ultrasonic



Best price-performance ratio sensor to monitor correct engine oil level.

- Benefits**
- › Replacement of oil dipstick
  - › Detection of low level and overflow
  - › Absolute measurement of oil level static / dynamic
  - › Low power consumption
  - › Temperature measurement optional
- Technical Information**
- › Measuring principle: Ultrasonic echo
  - › Measuring range: 18 mm up to 150 mm
  - › Level accuracy: +/- 2 mm
  - › Power supply: 12 V / 10 mA typical
  - › Protection class: IP X9K
  - › First measurement: Available after 0.4 sec.
  - › Measuring interval: 1 sec.
  - › Interface: PWM

## In Cylinder Pressure Sensor



Real-time combustion sensing, providing in-cylinder combustion pressure information.

- Benefits**
- › Tolerance compensation (injection, airpath, engine, fuel, etc.): Combustion stability control
  - › System cost improvement: Intake/exhaust models
  - › Airpath accuracy and dynamic control (O<sub>2</sub> intake based)
  - › Enables alternative combustion control (HCCI)
- Technical Information**
- › Embedded electronic using direct analog path - no time delay
  - › Independent of glow plug, improved robustness and signal
  - › Large bandwidth suitable for diesel and gasoline
  - › Output signal: 0 V up to 5 V (ratiometric)
  - › Measurement range: 0 bar up to 200 bar (adjustable)
  - › Temperature range: -40°C up to +150°C

## Knock Sensor M6 Small Design

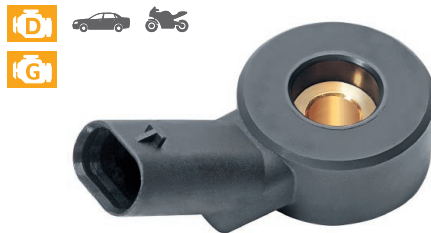

Measures structural vibrations in the internal combustion engine to continuously adjust ignition parameters.

- Benefits**
- › Optimization of ignition timing for max. efficiency
  - › High sensitivity
  - › Small design with M6 bolt for space and weight savings
  - › Increased engine power, decreased fuel consumption
  - › Fits for automotive, two-wheelers, and others
- Technical Information**
- › Acceleration sensor-based on piezo ceramic technology with a range of: 0 g up to 400 g
  - › Frequency range: 3 kHz up to 25 kHz
  - › Possible integration of discharge resistor
  - › Glue and nut designs available
  - › Compatible with current ECU designs

## Knock Sensor M8 Standard Design

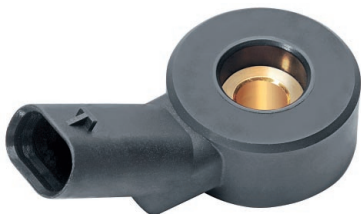

Measures structural vibrations in the combustion engine to continuously adjust ignition parameters.

- Benefits**
- › Optimized ignition timing for maximum efficiency
  - › High sensitivity
  - › Compact design, nested bolt possible
  - › Increase engine power
  - › Decrease fuel consumption

- Technical Information**
- › Acceleration sensor-based on piezo ceramic technology
  - › Frequency range: 3 kHz up to 25 kHz
  - › Possible integration of discharge resistor
  - › Integrated connector or cable version
  - › Nut and glue types assembly technology

## Latching Valve



Latching refueling valve is a bi-stable valve used to a seal-pressurized tank or isolated HC vapors in a normal tank.

- Benefits**
- › Significantly less energy consumption
  - › Maintains valve position using zero current draw
  - › Very low flow restriction
  - › Able to determine valve position (open/closed)
  - › Passive relief function for fuel tank over pressure

- Technical Information**
- › 14 V DC pulse for <100 ms to change valve state
  - › Flow: >115 SLPM at 1.5 kPa
  - › Overpressure relief at 43.5 kPa
  - › Leak: <1 sccm at 5 kPa and 20 kPa tank pressure
  - › Leak: <3.5 sccm at 35 kPa tank pressure
  - › Leak: <10 sccm at -9 kPa tank pressure

## Linear Purge Valve



The Linear Purge Valve controls hydrocarbon vapors from the canister to the intake manifold.

- Benefits**
- › Very low operating noise
  - › Fast response for incremental flow control at all operating conditions
  - › Excellent low end flow control preventing unwanted surges of fuel vapor
- Technical Information**
- › Typical flow: 70 SLPM at 57 kPa
  - › Operating voltage: 14 V
  - › Coil resistance: 14.0 Ohms
  - › Maximum current: 500 mA
  - › Control circuit constant current at: 150 Hz up to 200 Hz
  - › Weight: 200 g

## Natural Vacuum Leak Detection (NVLD III)

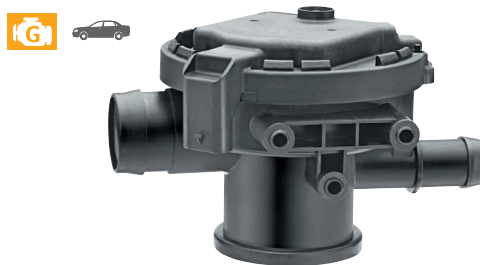

Engine-off OBD monitoring for hydrocarbon evaporative leak detection. Legislation compliance.

- Benefits**
- › With integrated electronics
  - › OBD HC leak diagnostic performed after key off
  - › Integrated solenoid for improved purge flow capacity
  - › Passive over pressure venting (including refueling)
  - › Temperature sensing; Switch sensing
- Technical Information**
- › Detection capable to 0.5mm diameter leak
  - › Bit serial communication with ECU
  - › High in use monitor performance
  - › Nominal coil resistance: 21 Ohms
  - › Operating temperature: -40°C up to +85°C
  - › 100 SLPM purge flow: <6 mbar  $\Delta$  pressure
  - › 100 SLPM refueling flow: <7 mbar  $\Delta$  pressure

## Pressure Sensor Brake Booster Absolute



Pressure measurement for start-stop applications.

### Benefits

- › Flexible calibration of transfer functions
- › Precision programmable clip levels
- › Internal and output diagnostic capability
- › High accuracy and temperature stability
- › Fulfills toughest EMC requirements

### Technical Information

- › Pressure range: 10 kPa up to 120 kPa
- › Accuracy: 1% full scale (10°C up to 85°C)
- › Temperature range: -40°C up to +140°C
- › Supply voltage: 5 V +/- 0.5 V
- › Supply current at 5 V: 10 mA maximum
- › Output signal: Analog or SENT

## Pressure Sensor Brake Booster Gauge

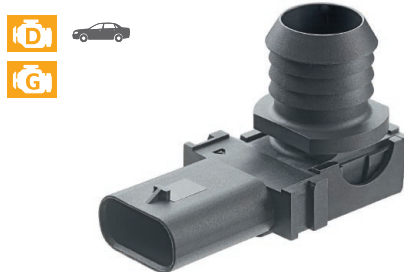

Relative measurement of vacuum inside brake booster.

### Benefits

- › Flexible calibration of transfer functions
- › Precision programmable clip levels
- › Internal and output diagnostic capability
- › High accuracy and temperature stability
- › Flexible housing, connector, and mounting designs

### Technical Information

- › Pressure range: -105 kPa up to 40 kPa (gauge)
- › Accuracy: 1% full scale (10°C up to 85°C)
- › Temperature range: -40°C up to +125°C
- › Supply voltage: 5 V +/- 0.5 V
- › Supply current at 5 V: 10 mA maximum
- › Load resistance: >4.7 kOhms
- › Output signal: Analog or SENT

## Pressure Sensor Filter Control Gauge

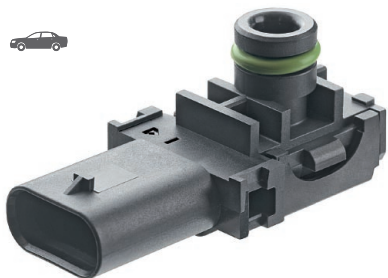

Relative measurement of pressure downstream of air filter.

### Benefits

- › Flexible calibration of transfer functions
- › Precision programmable clip levels
- › Internal and output diagnostic capability
- › High accuracy and temperature stability
- › Fulfills toughest EMC requirements
- › Flexible housing, connector, and mounting design

### Technical Information

- › Adjustable characteristic via electronic calibration
- › Pressure range: 0 kPa up to 10 kPa
- › Operating temp.: -40°C up to +125°C
- › Supply voltage: 5 V +/- 0.25 V
- › Output signal: Analog or SENT
- › Transfer function: Linear, ratiometric (analog version)
- › Accuracy: 3% full span (10°C up to 85°C) over full-scale

## Pressure Sensor - Filter Control Gauge



Air Filter  
Pressure

Relative pressure measurement used to monitor performance of intake air filter pressure measurement.

### Benefits

- › Flexible calibration of transfer functions
- › Precision programmable clip levels
- › Internal and output diagnostic capability
- › High accuracy and temperature stability
- › Fulfills toughest EMC requirements
- › Flexible housing, connector, and mounting design

### Technical Information

- › Adjustable characteristic via electronic calibration
- › Pressure range: -10 kPa up to 10 kPa
- › Operating temp.: -40°C up to +125°C
- › Supply voltage: 5 V ± 0.25 V
- › Output signal: Analog or SENT
- › Transfer function: Linear, ratiometric (analog version)
- › Accuracy: 3% full span (10°C up to 85°C) over full-scale

## Pressure Sensor - Filter Control Gauge



### Diesel Crankcase Pressure

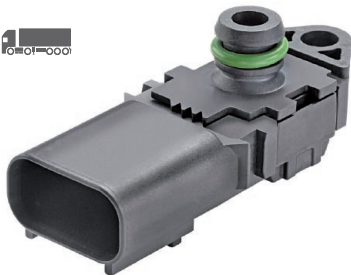

Relative pressure measurement used to monitor performance of positive crankcase ventilation system.

- Benefits**
- › Flexible calibration of transfer functions
  - › Precision programmable clip levels
  - › Internal and output diagnostic capability
  - › High accuracy and temperature stability
  - › Fulfills toughest EMC requirements
  - › Flexible housing, connector, and mounting design
- Technical Information**
- › Adjustable characteristic via electronic calibration
  - › Pressure range: -10 kPa up to 10 kPa
  - › Operating temp.: -40°C up to +125°C
  - › Supply voltage: 5 V  $\pm$  0.25 V
  - › Output signal: Analog or SENT
  - › Transfer function: Linear, ratiometric (analog version)
  - › Accuracy: 3% full span (10°C up to 85°C) over full-scale

## Pressure Sensor - Filter Control Gauge



### Gasoline Crankcase Pressure

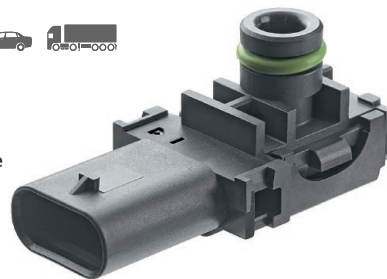

Relative pressure measurement used to monitor performance of positive crankcase ventilation system.

- Benefits**
- › Flexible calibration of transfer functions
  - › Precision programmable clip levels
  - › Internal and output diagnostic capability
  - › High accuracy and temperature stability
  - › Fulfills toughest EMC requirements
  - › Flexible housing, connector, and mounting design
- Technical Information**
- › Adjustable characteristic via electronic calibration
  - › Pressure range: 0 kPa up to 10 kPa
  - › Operating temp.: -40°C up to +125°C
  - › Supply voltage: 5 V  $\pm$  0.25 V
  - › Output signal: Analog or SENT
  - › Transfer function: Linear, ratiometric (analog version)
  - › Accuracy: 3% full span (10°C up to 85°C) over full-scale

## Pressure Sensor - Fuel Vapor Gauge



Relative pressure measurement used to detect any leak condition in evaporative fuel systems.

### Benefits

- › Flexible calibration of transfer functions
- › Precision programmable clip levels
- › Internal and output diagnostic capability
- › High accuracy and temperature stability
- › Fulfills toughest EMC requirements
- › Flexible housing, connector, and mounting design

### Technical Information

- › Adjustable characteristic via electronic calibration
- › Pressure range: -5 kPa up to 5 kPa
- › Operating temp.: -40°C up to +125°C
- › Supply voltage: 5 V  $\pm$  0.25 V
- › Output signal: Analog or SENT
- › Transfer function: Linear, ratiometric (analog version)
- › Accuracy: 1.5% full span (10°C up to 85°C) over full-scale

## Pressure Sensor High Pressure Diesel



Direct measurement of pressure in diesel fuel rail.

### Benefits

- › High accuracy and temperature stability
- › High vibration robustness (low / high frequencies)
- › Modular design for connector and mounting
- › Flexible calibration of transfer functions
- › Internal and output diagnostic capability

### Technical Information

- › Pressure range: 0 bar up to 3,000 bar
- › Temperature range: -40°C up to +140°C
- › Supply: 5 V, 10 mA
- › Output signal: Analog or SENT
- › Accuracy: 0.5% full scale output
- › Response time: < 1 ms

## Pressure Sensor High Pressure Gasoline

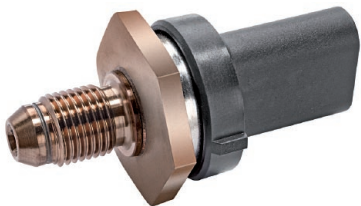

Direct measurement of pressure in gasoline fuel rail.

- Benefits**
- › High accuracy and temperature stability
  - › High vibration robustness (low/high frequencies)
  - › Modular design for connector and mounting
  - › Flexible calibration of transfer functions
  - › Internal and output diagnostic capability

- Technical Information**
- › Pressure range: 0 bar up to 500 bar
  - › Temperature range: -40°C up to +140°C
  - › Supply: 5 V, 10 mA
  - › Output signal: Analog or SENT
  - › Accuracy: 0.5% full scale output
  - › Response time: <1 ms

## Pressure Sensor Manifold Absolute



MAP  
TMAP  
BAP

Direct measurement of pressure in manifold.

- Benefits**
- › Flexible calibration of transfer functions
  - › High accuracy and temperature stability
  - › Low cost design and high quality
  - › Fulfills toughest EMC requirements
  - › Flexible housing, connector, and mounting design

- Technical Information**
- › Pressure range: 40 kPa up to 120 kPa (for BAP)
  - › Pressure range: 7 kPa up to 500 kPa (for MAP and Turbo MAP)
  - › Accuracy: 1% full scale (10°C up to 85°C)
  - › Temperature range: -40°C up to +140°C
  - › Output signal: Analog or SENT

## Pressure Sensor - Manifold Absolute and Temperature



MAP with integrated temperature sensor directly measures the pressure and temperature in the manifold.

- Benefits**
- › Flexible calibration of transfer functions
  - › High accuracy and temperature stability
  - › Low cost design and high quality
  - › Fulfills toughest EMC requirements
  - › Flexible housing, connector, and mounting design
- Technical Information**
- › Pressure range: 40 kPa up to 120 kPa (for TBAP)
  - › Pressure range: 7 kPa up to 500 kPa (for TMAP and Turbo TMAP)
  - › Accuracy: 1% full scale (10°C up to 85°C)
  - › Temperature range: -40°C up to +140°C
  - › Output signal: Analog or SENT

## Pressure Sensor Manifold Gauge



Relative measurement of pressure or vacuum in the intake manifold.

- Benefits**
- › Flexible calibration of transfer functions
  - › Precision programmable clip levels
  - › Internal and output diagnostic capability
  - › High accuracy and temperature stability
  - › Fulfills toughest EMC requirements
- Technical Information**
- › Pressure range: -105 kPa up to 40 kPa (gauge)
  - › Accuracy: 1% full scale (10°C up to 85°C)
  - › Temperature range: -40°C up to +125°C
  - › Supply voltage: 5 V +/- 0.5 V
  - › Supply current at 5 V: 10 mA maximum
  - › Load resistance: > 4.7 kOhms

## Temperature Sensor High Single

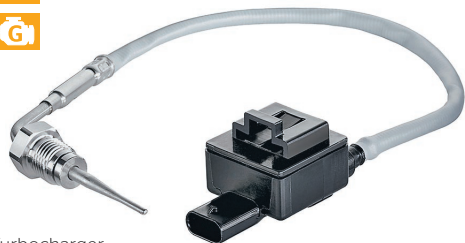

Turbocharger protection and exhaust temperature measurement.

### Benefits

- › Smart sensor with digital output, high accuracy
- › System price benefit
- › Stable signal over lifetime
- › Fast response due to small thermal inertia
- › Proven high temperature robustness

### Technical Information

- › Sensing technology: Thermocouple
- › Response time: 8 sec. at 10 m/s flow
- › Temperature range:
  - in production (diesel) -40°C up to +900°C
- › Working temp. electron.: -40°C up to +145°C
- › Accuracy:
  - 40°C up to +500°C: +/- 5°C
  - >500°C: +/- 1%
- › Output: SENT Interface

## Temperature Sensor Coolant / Fuel / Oil

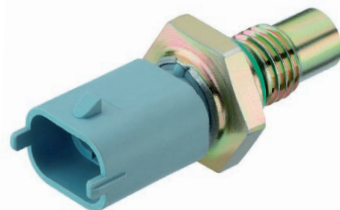

Temperature measurement in several liquid media (coolant water, oil, fuel).

### Benefits

- › Clip or screw-in design
- › Wide range of applications
- › High accuracy
- › Short response time
- › Long-term stability

### Technical Information

- › Oil, water, fuel, temperature measurement
  - Engine coolant: -40°C up to +140°C
  - Engine oil: -40°C up to +150°C
  - Fuel: -40°C up to +140°C
- › Accuracy: +/- 1°C (at 0°C)
- › Response time: Up to 3 s

## Turbo Purge Valve



The Turbo Purge Valve controls HC vapors from the canister to the turbo-charged intake manifold.

### Benefits

- › EVAP turbo system cost savings for OEM
- › Smooth start-to-open characteristics
- › Robust design and easy to calibrate
- › Multiple turbo purge system function in one assembly
- › Flexible configuration using common actuator

### Technical Information

- › Incorporates check valves to protect purge system
- › Operating voltage: 9 V up to 16 V (13.5 V optimal)
- › Operating temp.: -25°C up to +125°C
- › Operating pressure: Up to 400 kPa
- › Frequency: 5 Hz up to 30 Hz (10 Hz recommended)
- › Purge flow: 110 SLPM

## Variable Compression Ratio (VCR) Actuator



BLDC Motor for variable compression ratio actuation.

### Technical Information

- › High dynamics (low inertia)
  - › Field-oriented, sinus, and block commutation
- |                          |  |
|--------------------------|--|
| › Actuator size approx.: | D 150 x 70 mm                                |
| › EC motor stator size:  | D 65 x 20 mm                                 |
| › Nominal Torque:        | 1.7 Nm                                       |
| › Max. EC motor power:   | 400 W  |
| › Stator Slots number:   | 12   |
| › Rotor poles number:    | 10   |
| › Operation mode:        | Field-oriented, sinus, and block commutation |
- › Phase nr. and connection: 3 Δ
  - › Operating temperature: -40°C up to 140°C (stator potting)

## Variable Turbine Geometry Actuator



Best performance for VTG adjustment to optimize functional application and reduce fuel consumption.

### Benefits

- › Continuous adjustment of external application using rotating output shaft
- › Ideal for use in VTG applications
- › Permanent feedback signal (contactless)
- › Options: Default position, integrated electronic

### Technical Information

- › Max. external load without return function: 40 Ncm
- › Max. continuous holding torque without return function at 140°C: 65 Ncm
- › Response time: < 150 ms at 120°C
- › Operation temperature: -40°C up to +160°C



**Doing more. For Clean Power.**  
Powertrain

## Exhaust After-treatment Solutions

### A Clean Solution.

Not everything your engine emits necessarily needs to be converted into emissions. Systematic thinking is called for here as well. With the right combination of combustion, electrification and exhaust after-treatment, the strengths of all three elements can complement one another while compensating for each others' weaknesses.

An electrically heated catalytic converter in a hybrid, for instance, ensures that the emission clean-up is activated immediately after the cooled combustion engine starts again, even after the vehicle has been coasting without using its engine for quite some time. For exhaust after-treatment as well: Only the pooling of clean energy expertise - materials, processes, innovative designs and economical production - with sensor technology and actuators, the engine control unit and energy management system deliver the best results. It is a task that demands systems expertise.

Continental Powertrain offers an optimal range of technologies as the groundwork for especially high-performance exhaust after-treatment - from catalytic converters and filters to SCR. A clean solution.



# After-treatment

## After-treatment Control Module

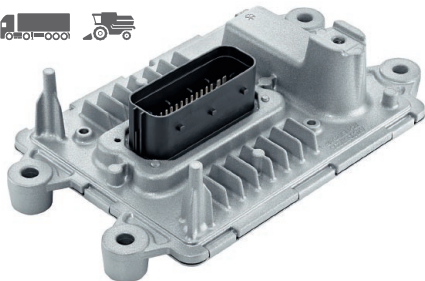

Controller for exhaust after-treatment systems (SCR, DPF).

- Benefits**
- › 12 V/24 V supply
  - › Supports CAN based sensors (e.g. NO<sub>x</sub>, urea quality)
  - › Chassis-mounted (under hood)

- Technical Information**
- › Core: Andorra
  - › Flash size: 4 MB
  - › Interfaces: 3 CAN
  - › Injector drivers: 3 urea or HC dosing
  - › Driver outputs: 4 high-side + 19 low-side
  - › Tightness: IP5K6K
  - › Connector pins: 62

## Air-Cooled SCR Injector



Key technology in the area of NO<sub>x</sub> reduction to meet the future emission legislations.

- Benefits**
- › Single fluid airless system
  - › Simple and reliable delivery of urea with excellent spray performance
  - › Multiple spray configurations
- Technical Information**
- › Spray patterns: Cone, bent, elliptical
  - › Sauter Mean Diameter (SMD): 70 μm up to 155 μm dependent upon OD
  - › Fluid pressure range: 4 bar up to 9 bar
  - › Max. body/ambient temp.: 160°C continuous
  - › Max. tip fluid temperature: 120°C continuous with peaks to 130°C
  - › Max. inlet temperature: 110°C continuous

## Liquid-Cooled SCR Injector



Liquid-cooled SCR dosing unit for NO<sub>x</sub> reduction in close coupled applications.

### Benefits

- › Simple and reliable delivery of urea with excellent spray performance
- › Multiple spray configurations
- › Flexible design helps packaging in engine compartment environment

### Technical Information

- › Spray patterns: Cone and elliptical
- › Sauter Mean Diameter (SMD): 60 μm up to 130 μm (5 bar)
- › Fluid pressure range: 4 bar up to 6.5 bar
- › Max. injector fluid tip temp.: 130°C peak
- › Max. ambient temperature: 200°C continuous

## Urea Dosing Control Unit



Standardized, validated electronic, and SW platform for NO<sub>x</sub> after-treatment control of passenger vehicles.

### Benefits

- › Proven mechanical and electronic concepts (driver, ASICs etc.)
- › One or two chambers connector approach enables optimized wiring harness
- › Direct connection to ECU and pump module
- › 12 V application

### Technical Information

- › Core: Bolero
- › Flash size: 1 MB
- › Interfaces: CAN, SENT, PWM
- › Injector drivers: High-/low-side
- › Heater driver: 2 + 1 optional
- › Pump driver: BLDC pump + optional transfer pump
- › Housing: Plastic housing; IPX6K9

## CS-Design (Crossversal Structure)

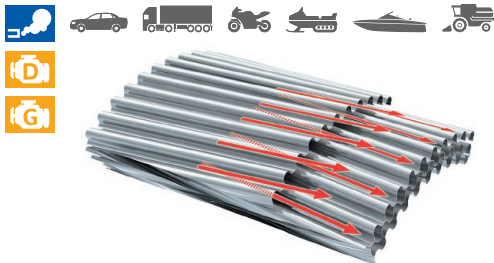

New metallic substrate design to increase efficiency during cold start and warm up without penalty in backpressure.

- Benefits**
- › Material and cost saving due to elimination of flat foils
  - › GSA compensation by higher cell density of corrugated layer and improved mass transfer
  - › Improved coating distribution due to reduced contact lines
  - › Lower back pressure compared to equal efficiency standard substrate
- Technical Information**
- › Cross corrugated foils without flat foil layer
  - › Metal substrate to be coated with various catalyst formulations for combustion engine exhaust emission control
  - › Application as three-way catalyst for gasoline engines as well as DOC, NOx-adsorber, and SCR catalyst for diesel engines
  - › Variance of cell densities and foil thicknesses

## LS-Design® (Longitudinal Structure)

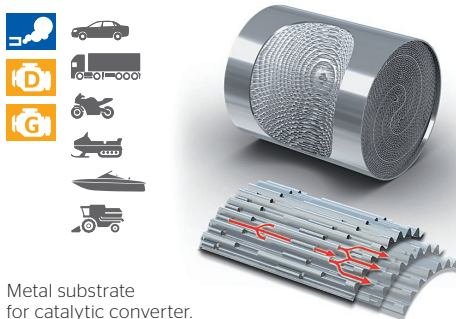

Metal substrate for catalytic converter.

- Benefits**
- › Further increased catalytic efficiency compared to standard structure, due to turbulence generating secondary corrugation
  - › Significant performance improvement - alternative to higher cell density
  - › Less material, improved light-off-performance, cost-effective
- Technical Information**
- › Metal substrate to be coated with various catalyst formulations for combustion engine exhaust emission control
  - › Application as three-way catalyst for gasoline engines as well as DOC, NOx-adsorber and SCR catalyst for diesel engines
  - › Cell density from 100/200 cpsi up to 400/800 cpsi
  - › Foil thickness 40 up to 80 µm (1.6 up to 3.2 mil)

## LS-Design® and PE-Design®

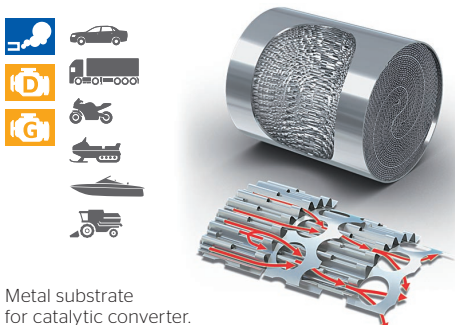

Metal substrate  
for catalytic converter.

- Benefits**
- › Increased catalytic efficiency compared to standard structure, TS structure, and ceramic substrates due to turbulence generating secondary corrugation
  - › Performance improvement in case of flow or concentration inhomogeneity at catalyst inlet
- Technical Information**
- › Metal substrate to be coated with various catalyst formulations for combustion engine exhaust emission control
  - › Application as three-way catalyst for gasoline engines as well as DOC and SCR catalyst for diesel engines
  - › Cell density from 100/200 cpsi up to 400/800 cpsi
  - › Foil thickness 40 up to 80  $\mu\text{m}$  (1.6 up to 3.2 mil)

## MX-Design® (Mixing Structure)

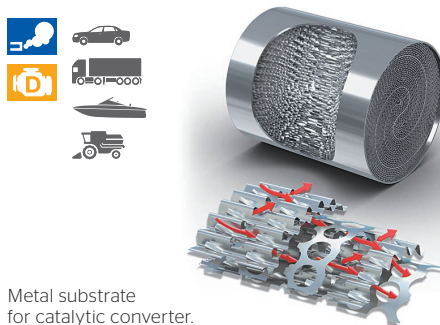

Metal substrate  
for catalytic converter.

- Benefits**
- › Shovels and perforation assure droplets will hit catalytic wall and evaporate rather than pass through
  - › Reduces / eliminates risk of deposit formation downstream of the substrate
  - › MX with hydrolysis coating improves urea conversion to ammonia for SCR-reaction
- Technical Information**
- › Metal substrate to be coated with hydrolysis formulation for diesel engine exhaust emission control
  - › Application as evaporator and hydrolysis catalyst for injected reductant in SCR applications
  - › Low cell density shovel corrugation combined with perforated flat foils
  - › Cell density 40 cpsi
  - › Foil thickness 65  $\mu\text{m}$  (2.6 mil)

## PE-Design® (Perforated Structure)

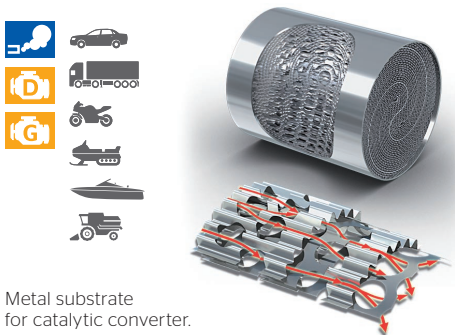

Metal substrate  
for catalytic converter.

- Benefits**
- › Perforation of corrugated and flat layer results in light weight
  - › Less material, improved light-off performance
  - › Low backpressure and better utilization of catalyst volume by flow homogenization
  - › Significant performance improvement in case of flow- or concentration-inhomogeneity at catalyst inlet
- Technical Information**
- › Metal substrate to be coated with various catalyst formulations for combustion engine exhaust emission control
  - › Application in special as three-way catalyst for gasoline engines
  - › Cell density from 100 cpsi up to 900 cpsi
  - › Foil thickness 40 up to 80  $\mu\text{m}$  (1.6 up to 3.2 mil)

## TS-Design® (Transversal Structure)

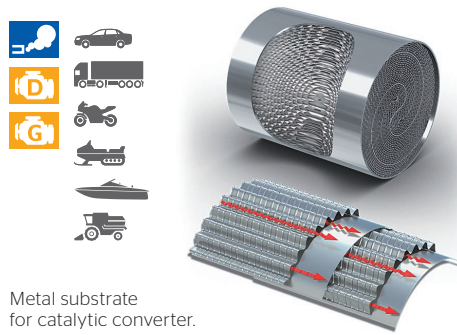

Metal substrate  
for catalytic converter.

- Benefits**
- › Improved conversion performance by transversal structure corrugation (TS-Design®)
  - › Increased catalytic efficiency compared to standard structure and ceramic substrates
  - › Backpressure advantage
  - › Smaller package space
- Technical Information**
- › Metal substrate to be coated with various catalyst formulations for combustion engine exhaust emission control
  - › Application as three-way catalyst for gasoline engines as well as DOC, NO<sub>x</sub>-adsorber, and SCR catalyst for diesel engines
  - › Cell density from 100 cpsi up to 500 cpsi
  - › Foil thickness 40 up to 110  $\mu\text{m}$  (1.6 up to 4.3 mil)

## Straight Channel METALIT® (Standard Structure)

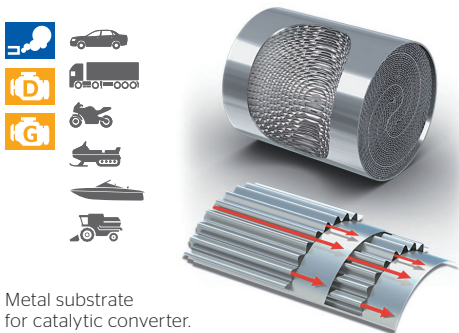

Metal substrate  
for catalytic converter.

- Benefits**
- › Larger geometric surface area than ceramic substrates
  - › Improved cold-start performance
  - › Lower backpressure
  - › Smaller package space
  - › Easy canning into the exhaust system by welding
- Technical Information**
- › Metal substrate to be coated with various catalyst formulations for combustion engine exhaust emission control
  - › Application as three-way catalyst for gasoline engines as well as DOC, NO<sub>x</sub>-adsorber, and SCR catalyst for diesel engines
  - › Cell density from 50 cpsi up to 1600 cpsi
  - › Foil thickness 25 up to 110 μm (1 up to 4.3 mil)

## Thin Wall and Lightweight Catalyst



Thin mantle for catalysts with lower weight, costs and thermal mass. Increase of the thermo-mechanical durability.

- Benefits**
- › Reduction of substrate weight
  - › Increase thermo-mechanical durability
  - › Faster light-off
  - › Structured surface to increase stiffness
- Technical Information**
- › Typical substrate diameter range: 30 up to 93 mm
  - › Typical substrate length range: 25 up to 101.5 mm
  - › Mantle material: 1.4509

## Controller for Electrically Heated Catalyst (EMICAT®)



Power control for the Electrically Heated Catalyst EMICAT®, based on a 32 bit microcontroller unit.

- Benefits**
- › CAN interface for communication with ECU and SCR controller
  - › Diagnostic and development tools via CAN
  - › Electrically protected output (overcurrent, short circuit to ground and battery)
  - › EMC compatible design
- Technical Information**
- › Voltage: 12/24 V (48 V in devel.)
  - › Electrical Power: 1.6 kW (12V), 2.5 kW (24V), 3.0 kW (48V)
  - › Max. continuous current: 180 A (12 V), 140 A (24 V), 80 A (48V)
  - › PWM controlled power, 10 Hz base frequency
  - › IP6K9K protection class
  - › Ambient temperatures: -40°C up to +85°C

## EMICAT® Electrically Heated Catalyst

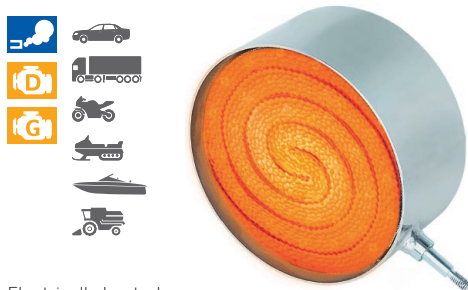

Electrically heated catalyst including a high effective support catalyst.

- Benefits**
- › Catalyst light off temperature reached in less time
  - › Reduced catalyst cooling during no-load phases
  - › Potential for precious metal reduction
  - › Additional energy supports vaporization of liquids
  - › Improved low-temperature SCR
- Technical Information**
- › Intelligent activation for lower heating power
  - › Use of recuperation energy
  - › Support of RDE challenges
  - › Operation voltage: 12 V/24 V/48 V
  - › Power at 12 V: 300 W up to 3,600 W
  - › Power at 24 V: 1,000 W up to 7,200 W
  - › Power at 48 V: 500 W up to 4,000 W
  - › Diameter: 50 mm up to 264 mm

## Three-Way Catalyst (TWC)

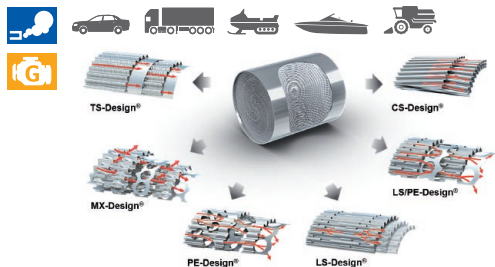

METALIT® catalyst reducing simultaneously hydrocarbon (HC), carbon monoxide (CO), and nitrogen oxides (NO<sub>x</sub>).

- Benefits**
- › High-performance catalyst based on turbulent flow structure
  - › Reduced catalyst volume results in lower space requirement
  - › Low backpressure for optimum fuel consumption and maximum power

- Technical Information**
- › TWC coating with platinum and rhodium for oxidation and rhodium for reduction
  - › Wide variety of round and non-round geometries available
  - › Serial production diameter up to 450 mm
  - › Cell density and foil structure applicable to customer requirements

## Diesel Oxidation Catalyst (DOC)



Oxidizing hydrocarbon (HC) and carbon monoxide (CO).

- Benefits**
- › High-performance catalysts based on turbulence-generating substrate structure
  - › Possible with integrated air gap insulation for minimum space requirements in the engine compartment
  - › Low backpressure for optimum fuel consumption
  - › Robust design

- Technical Information**
- › Oxidizing catalyst coating with platinum and palladium
  - › Wide variety of round and non-round geometries available
  - › Serial production diameter up to 450 mm
  - › Cell density and foil structure applicable to customer requirements

## SCR Catalyst

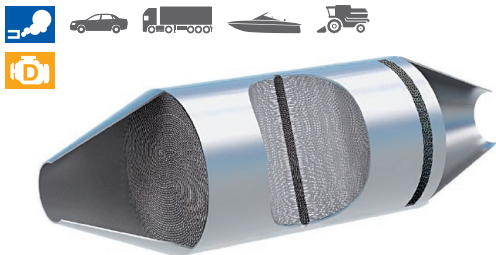

NO<sub>x</sub> reduction for all types of diesel engines in combination with Continental Ad Blue® dosing systems.

### Benefits

- › High-performance reduction catalysts based on turbulence-generating substrate structure
- › Reduced catalyst volume results in lower space requirement
- › Low backpressure for optimum fuel consumption
- › Ammonia slip catalyst as a very short disc in metal design

### Technical information

- › Wide variety of round and non-round geometries available
- › Serial production diameter up to 450 mm
- › Cell density and foil structure optimized to application
- › New CS-Design as a perfect base
- › Lowest slip catalyst length, down to 20 mm

## SCR Light-Off Catalyst

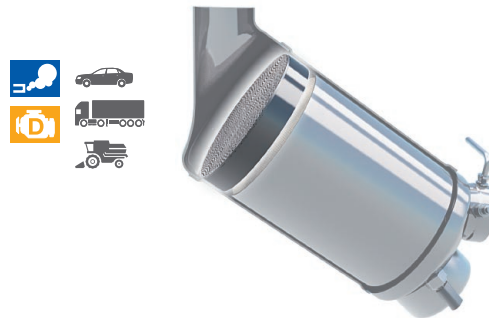

Small catalyst slice on front of the SDPF improves the system behaviour and the overall NO<sub>x</sub> reduction efficiency.

### Benefits

- › SCR efficiency improvement in cold and transient operation
- › Short slice in front of the DPF to achieve low thermal capacity
- › Further reduction of thermal capacity by using PE-Design®

### Technical information

- › SCR-coating: Base metals (vanadium) or zeolites
- › Cell density and foil structure optimized to application
- › Typical SCR Light-Off Catalyst length between 20 and 50.8 mm

## Exhaust After-treatment System for Two-Wheeler



Small catalysts which can be combined to an efficient two-wheeler exhaust after-treatment system.

- Benefits**
- › High-performance catalysts based on turbulent flow structure
  - › Low backpressure for high power applications
  - › Robust design
  - › Applicable for 2- and 3-wheelers
- Technical Information**
- › Wide variety of round and non-round geometries available
  - › Very small diameters possible,  $\varnothing \geq 30$  mm
  - › Cell density and foil structure applicable to customer requirements

## Close-Coupled After-treatment System Gasoline



Three-way catalyst substrate for lowest emission gasoline cars.

- Benefits**
- › Lowest emissions due to fast light-off in close-coupled position
  - › "CompactCat" canning provides optimum exhaust gas temperature utilization
  - › Engine control response and accuracy optimized by catalyst-integrated lambda-sensor (Lambdasondenkat™)
- Technical Information**
- › High-performance metal substrate with LS structure /LS-Design®
  - › Close-coupled position directly at turbocharger outlet
  - › "CompactCat" canning with hot gas circulating the catalyst surfaces
  - › Same components utilized also in SULEV and Diesel engine applications

## Close-Coupled After-treatment System Light-Duty (LDD)



Oxidation catalyst substrate for lowest emission diesel cars.

- Benefits**
- › Lowest emissions due to fast light-off in close-coupled position
  - › "CompactCat" canning provides optimum exhaust gas temperature utilization
  - › Optimum flow distribution to directly connected Diesel particulate filter
- Technical Information**
- › High-performance metal substrate with LS-Design®
  - › Close-coupled position directly at turbocharger outlet
  - › "CompactCat" canning with hot gas circulating the catalyst surfaces
  - › Same components utilized also in SULEV and other Gasoline engine applications

## Compact Catalyst

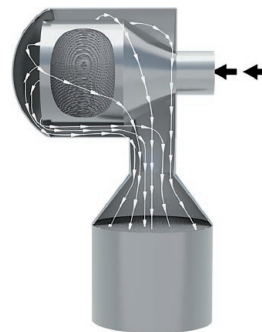

Close-coupled mounted catalyst integrated in a reverse chamber flow.

- Benefits**
- › Highest inlet gas temperatures
  - › High catalyst volume
  - › Low back pressure
  - › Reduced heat capacity substrate
- Technical Information**
- › Complete outer insulation possible
  - › Close-coupled mounted catalyst
  - › Catalyst insulated by exhaust gas
  - › Integrated functions: Sensor, heating (EMICAT®), NH<sub>3</sub> mixing without static mixer

## Compact SCR EHC System Light Duty (LDD)



Oxidation catalyst in combination with electrical heated catalyst EMICAT® and reverse reductant injection.

- Benefits**
- › Lowest emissions due to fast light-off in close-coupled position
  - › Ammonia formation at lowest temperatures with EHC support
  - › Optimum flow distribution to directly connected SCR-coated diesel particulate filter
- Technical Information**
- › Reverse reductant injection on hydrolysis coated heating disc
  - › High-performance metal substrate with LS structure/LS-Design®
  - › "CompactCat" canning with hot gas circulating the catalyst surfaces in close-coupled position
  - › Electrical Heated Catalyst (EMICAT®) for 12 up to 48 V / 0.3 up to 4 kW

## Sensor Catalyst



Catalyst with integrated hole for sensors.

- Benefits**
- › Optimization of space compartment
  - › Protection of the sensors against water splash
  - › Direct and fast measuring in the catalyst to avoid breakthrough
- Technical Information**
- › Temperature, NO<sub>x</sub> und Lamda sensors can be integrated in the METALIT® catalyst
  - › Combination with LS or PE structure is possible for flow uniformity

## Close-Coupled After-treatment System Heavy-Duty (HDD)

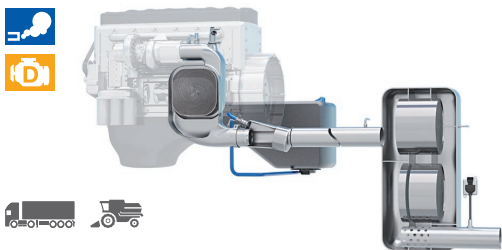

Exhaust after-treatment in close-coupled position shows advantages as already demonstrated in passenger cars.

- Benefits**
- › Heat loss reduction leads to improvement at cold-start and at intra-urban use
  - › Improvement of thermal management for DOC as well as for the whole exhaust system
  - › AdBlue® (DEF) injection at higher temperatures
  - › Better homogenization of Ammonia in front of SCR components
- Technical Information**
- › AdBlue® (DEF) injection at higher temperatures
  - › Volume reduction of the total system
  - › Optimization for fast light-off and highest conversion rates
  - › Future-oriented for SCR-coated DPF
  - › UDP design scalable to the engine size
  - › Optional with EMICAT® for further low temperature decomposition enhancement

## Close-Coupled Oxidation Catalyst Heavy-Duty (HDD)

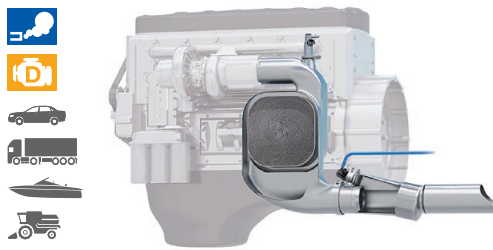

Close-coupled diesel oxidation catalysts can utilize higher exhaust temperatures for further decreased emission limits.

- Benefits**
- › Even the limited space all around the engine can be used by design freedom
  - › Heat loss reduction leads to improvement at cold-start and at intra-urban use
  - › Improvement of thermal management for DOC as well as for the whole exhaust system
  - › AdBlue® (DEF) injection at higher temperatures
- Technical Information**
- › METALIT® catalyst substrate in a wide range of size and geometrical shape
  - › DOC-volume reduction up to 30%
  - › Optimization for fast light-off and CRT
  - › Applicable even to existing vehicle concepts

## Universal Decomposition Pipe (UDP)

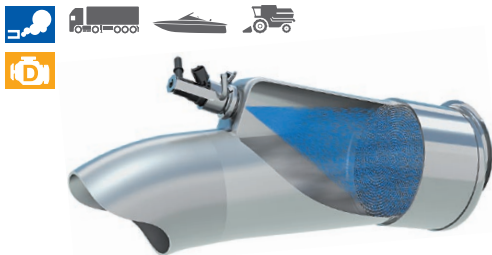

In-pipe AdBlue® (DEF) injection and Urea decomposition engineered in modular sizes for specific power ratings.

- Benefits**
- › Flexible in pipe installation
  - › Fast evaporation of AdBlue® (DEF) droplets
  - › Integrated thermolysis of AdBlue® (DEF) droplets and hydrolysis to Ammonia
  - › AdBlue® (DEF) dosing at low temperature duty cycles
  - › Mixing of Ammonia with exhaust gas
- Technical Information**
- › Stainless steel housing with cockpit for SCR injector installation
  - › Defined inlet geometry with confuser for flow guidance
  - › Evaporator with coated METALIT®
  - › METALIT® in MX-Design® with integrated shovels for enhanced droplet evaporation
  - › Optional with electrically heated catalyst EMICAT® for further low temperature decomposition enhancement

## Ring-Shape DOC for Advanced Compact SCR

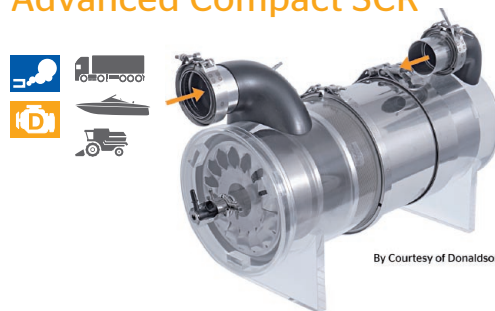

By Courtesy of Donaldson

Ring-shape Metalit® for DOC function in SCR systems with integrated Urea decomposition feature in the center.

- Benefits**
- › Inner hot tube with high droplet evaporation capability due to intense turbulent gas flow
  - › Usage of outer mantle design for flow guidance (principle feature of CompactCat® design)
  - › Compact robust system build
  - › Minimized thermal mass for low temperature AdBlue® (DEF) decomposition
- Technical Information**
- › Metallic substrate with high efficient foil structure
  - › Scalable substrate with inner tube for flow guidance towards SDPF
  - › Easy integration with customized mantle tube design

## Ring Catalyst

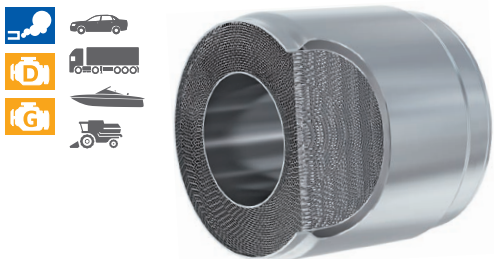

Ring shaped catalyst consisting of an outer mantle, a ring shaped matrix, and an inner mantle.

- Benefits**
- › Improvement of single cylinder lambda distribution due to high turbulent mixing zone
  - › Less influence of wastegate on flow distribution
  - › Lower aging
  - › Compact design

- Technical Information**
- › Substrate length: 50.8 mm up to 174 mm
  - › Cell density: 100 cpsi up to 800 cpsi
  - › Foil design: LS; LS-PE; PE; PM
  - › Diameter outer mantle: 130 mm up to 450 mm
  - › Diameter inner mantle: 50 mm up to 300 mm

## Ring-Shape SCR EHC System

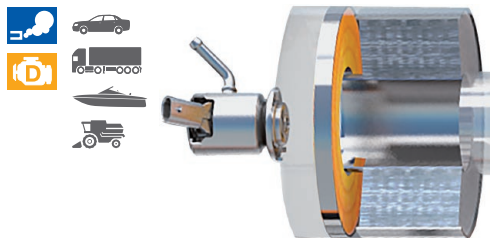

Ring-Shape EMICAT® with integrated mixing and thermolysis pipe for highest NO<sub>x</sub> reduction requirements.

- Benefits**
- › Earlier dosing release by electrical heating
  - › Inner hot tube with high droplet evaporation capability, decomposition of reduction agent at hottest environment
  - › Increased Ammonia uniformity for SCR catalyst
  - › Very compact system design

- Technical Information**
- › Compact system approach with scalable outer and inner tube depending on application
  - › Variation of heating power according to requirements
  - › EMICAT® for 12, 24 and 48 V application
  - › EMICAT® in round and non-round ring-shape
  - › Ring-Shape EMICAT® with control unit as a complete system

## Particulate Matter Filter PM-METALIT®



Partial-flow deep-bed filter for particulate matter of diesel engines with reduced maintenance demand.

- Benefits**
- › Passive soot regeneration by  $\text{NO}_2$  in combination with a DOC
  - › Active regeneration by engine measures or diesel injection not required
  - › Rapid regeneration in wide operating temperature window
- Technical Information**
- › PM-METALIT® filter to reduce particulate matter emissions
  - › Proven filter system to meet EU/China IV/V, Tier 4i/f and similar exhaust emission regulations
  - › Maintenance-free with appropriate engine fuel and oil specifications

## Exhaust Gas Recirculation Filter



Lifetime EGR-filter with highest efficiency to protect turbo-charger from ceramic particles due to DPF regeneration.

- Benefits**
- › Optimum engine dynamics
  - › Component protection for exhaust gas turbocharger and engine
  - › Utilization for DPF OBD
  - › Replacement for soot sensor
- Technical Information**
- › Usage of high efficient 2-layer TELA-wire mesh
  - › Evolvent weaving structure (GKD)
  - › Optimized filter efficiency
  - › High mechanical durability

## Metallic Gasoline Particle Filter



Filtration at low pressure loss for application in gasoline engines to meet future's particle emission legislation (RDE).

### Benefits

- › Application as an add-on solution additional to a close coupled three-way-catalyst in uncoated condition
- › Pressure drop significantly lower than comparable ceramic systems
- › Support of RDE challenges

### Technical Information

- › High filtration efficiency of PM and PN
- › Represents an ash tolerant solution
- › Diameter range: 90 mm up to 150 mm
- › Length range: 50 mm up to 200 mm
- › Specific filter surface area: 0.4 m<sup>2</sup>/Liter

## Air-Assisted Urea Dosing Unit UDA

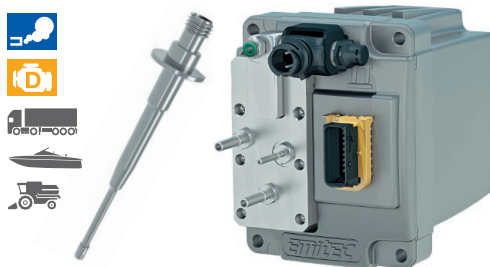

Air-assisted AdBlue® (DEF) metering pump unit in combination with a passive working two-phase nozzle.

### Benefits

- › Robust and proven frame mounted pump unit
- › Low consumption of compressed air
- › Fine spray quality due to air-atomization of urea
- › Designed for heavy duty trucks, NRMM, and retrofit
- › Injection into high pressure exhaust (pre-turbo)

### Technical Information

- › Pump Capacity: 7.5 l/h
- › Operating pressure: nominal 3 bar up to 6 bar
- › Integrated electronic control
- › Master, slave, and stand-alone modes
- › Compressed air control and mixing inside
- › Precise urea metering by membrane pump

## Tank-Integrated SCR Urea Extraction Unit Gen 4

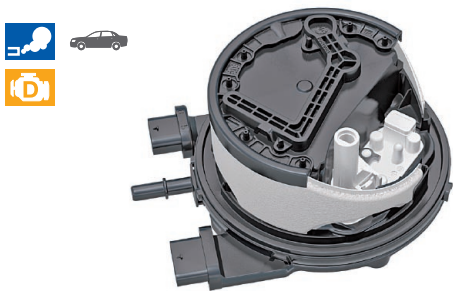

Tank-integrated urea extraction and pump unit "Gen 4".

- Benefits**
- › Including filter, heating, level, and quality sensor
  - › Controlled pressure for stable spray pattern
  - › Silent orbital pump with purge functionality
  - › Maintenance-free lifetime filter
  - › Freeze proven
  - › Welded directly into the tank
- Technical Information**
- › Pump capacity: 2.7 l/h
  - › Operating pressure: 5 bar up to 5.5 bar (relative)
  - › Operating voltage: 12 V

## Tank-Integrated SCR Urea Extraction Unit Gen III

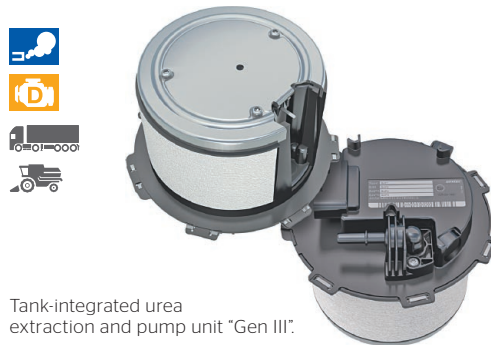

Tank-integrated urea extraction and pump unit "Gen III".

- Benefits**
- › Including filter, heating, level, and quality sensor
  - › Including integrated SCR dosing control unit (master, slave, stand alone), injector driver
  - › Reduced number of system components
  - › Freeze proven no-purged system
- Technical Information**
- › Robust piston pump, maintenance-free lifetime filter
  - › CAN-connection to NOx- and Temperature sensors
  - › Pump capacity: 8 l/h
  - › Operating pressure: 5 bar up to 8 bar (relative)
  - › Voltage: 12 V and 24 V

## Electrostatic Particulate Matter Sensor



Sensor for On-Board Diagnosis of Diesel Particulate Filters.

### Benefits

- › High signal availability reduces calibration effort and enables high IUPR
- › Reliable filter OBD ensured by activation of monitoring function only at robust conditions for sensor and engine
- › No effect of exhaust gas composites on the PM measurement signal ( $\text{NO}$ ,  $\text{NO}_2$ ,  $\text{O}_2$ ,  $\text{NH}_3$ )

### Technical Information

- › Measuring range: 0  $\text{mg}/\text{m}^3$  up to 25  $\text{mg}/\text{m}^3$
- › Accuracy (ref. bench):  $\pm 20\%$  above 2.5  $\text{mg}/\text{m}^3$
- › Accuracy (ref. bench):  $\pm 0.5$   $\text{mg}/\text{m}^3$  below 2.5  $\text{mg}/\text{m}^3$
- › Gas temperature: Up to 950°C
- › Data link: CAN 2.0 or SAE-J-1939

## Fluid Sensor - Urea Concentration and Level



Urea Concentration and Level Sensor helps to fulfill emission legislation and OBD requirements for SCR systems.

### Benefits

- › Fast and accurate measurement of urea concentration (AdBlue®/DEF) in the SCR system.
- › Additional measurement of urea level and temperature
- › Proven sensor technology

### Technical Information

- › Measuring principle: Ultrasonic
- › Output signal: CAN
- › Measuring range: Concentration 0% up to 50%
- › Urea mass above freezing point, level: 20 mm up to 500 mm
- › Accuracy: Concentration -2% urea mass
- › Level: +/- 2 mm (up to 200 mm)
- › Measurement possible under inclination

## Mass Airflow Sensor FMT MAF SENT

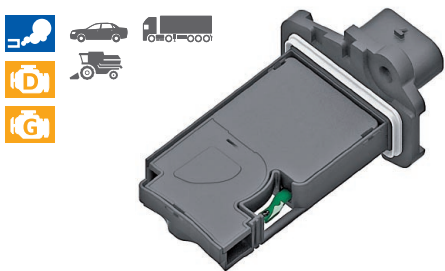

Measures intake airflow and temperature for the engine management system with option for SENT interface.

- Benefits**
- › High flow measurement accuracy
  - › Integral protection against water and contamination
  - › Excellent performance with intake airflow pulsation
  - › Enhanced EMC performance
  - › 3 pin device with SENT V4 interface
- Technical Information**
- › Sensing technology: Next generation MEMS
  - › Flow range: 4.5 kg/h up to 900 kg/h (62 mm tube)
  - › New-part tolerance: 1.3%
  - › Supply voltage: 5 V +/- 0.5 V
  - › Supply current: 5 mA
  - › Intake air temperature sensor optional
  - › Output signal: Frequency or SENT V4

## Mass Airflow Sensor FMT MAF+HPT SENT

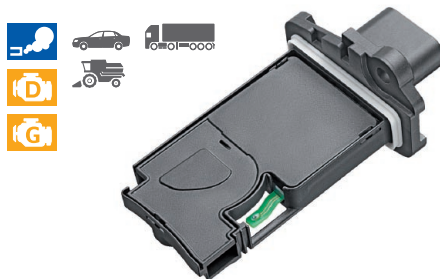

Measurement of the intake airflow humidity, pressure, and temperature for the engine management system.

- Benefits**
- › High flow measurement accuracy
  - › Integral protection against water and contamination
  - › Excellent performance with intake airflow pulsation
  - › Enhanced EMC performance
  - › Options for humidity and pressure sensors
- Technical Information**
- › Sensing technology: Next generation MEMS
  - › Flow range: 4.5 kg/h up to 900 kg/h (62 mm tube)
  - › New-part tolerance: 1.3%
  - › Supply voltage: 5 V +/- 0.5 V
  - › Output signal: SENT V4

## Mass Airflow Sensor MT MAF



Measurement of the intake airflow for the engine management system.

- Benefits**
- › High flow measurement accuracy and signal stability
  - › Integral protection against water and contamination
  - › Excellent performance with intake airflow pulsation
  - › Customer specific programmable output characteristic

- Technical Information**
- › Sensing technology: Hot-film bi-directional MEMS
  - › Flow range: 5 kg/h up to 800 kg/h (62 mm tube)
  - › New-part tolerance: 1.5%
  - › Supply voltage: 5 V +/- 0.5 V
  - › Supply current: 8 mA maximum
  - › Output signal: Frequency
  - › Intake air temperature sensor optional

## Pressure Sensor - Particle Filter/ EGR Differential

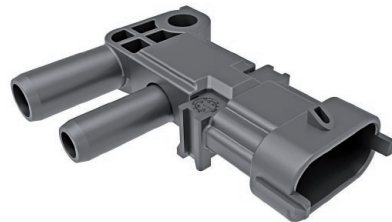

Differential measurement of exhaust treatment particle filter pressure drop / across EGR orifice.

- Benefits**
- › Flexible calibration of transfer functions
  - › Precision programmable clip levels
  - › Internal and output diagnostic capability
  - › High accuracy and temperature stability
  - › Flexible housing, connector and mounting design

- Technical Information**
- › Pressure range: -50 kPa up to +100 kPa (differential)
  - › Accuracy: 1% full scale (10°C up to 85°C)
  - › Temperature range: -40°C up to +125°C
  - › Supply voltage: 5V ± 0.5V
  - › Supply current at 5 V: 10 mA max
  - › Load resistance: > 4.7 kOhms
  - › Output signal: Analog or SENT

## Pressure Sensor - Particle Filter Gauge (Single Port)

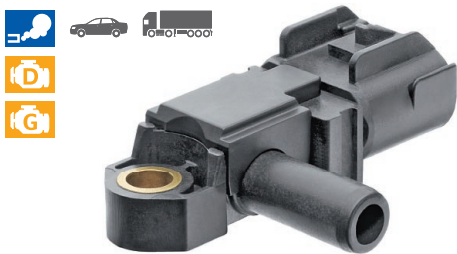

Relative measurement of exhaust pressure before or after the DPF.

### Benefits

- > Flexible calibration of transfer functions
- > Precision programmable clip levels
- > Internal and output diagnostic capability
- > High accuracy and temperature stability
- > Fulfills toughest EMC requirements

### Technical Information

- > Pressure range: 0 kPa up to 125 kPa
- > Accuracy: 1% full scale (10°C up to 85°C)
- > Temperature range: -40°C up to +125°C
- > Supply voltage (Vs): 5 V +/- 0.5 V
- > Supply current at 5 V: 10 mA maximum
- > Load resistance: > 4.7 kOhms
- > Response time: < 2 ms

## Pressure Sensor Secondary Air Absolute



Direct measurement of pressure in secondary air flow.

### Benefits

- > Flexible calibration of transfer functions
- > High accuracy and temperature stability
- > Low cost design and high quality
- > Fulfills toughest EMC requirements
- > Flexible housing, connector, and mounting design

### Technical Information

- > Pressure range: 50 kPa up to 150 kPa (for SAA)
- > Accuracy: 1% full scale (10°C up to 85°C)
- > Temperature range: -40°C up to +140°C
- > Supply voltage: 5 V +/- 0.5 V
- > Supply current at 5 V: 10 mA maximum
- > Load resistance: > 4.7 kOhms

## Smart NO<sub>x</sub> Sensor Gen 4.0A



NO<sub>x</sub> measurement, upstream or downstream SCR. Optimizes urea injection.

### Benefits

- › Real time high accuracy measurement
- › Sensor performance independent of catalyst or ECU supplier and engine management system
- › Modular "Stand-alone" NO<sub>x</sub> sensor enabling EU/US/Japan emission standards compliance

### Technical Information

- › Measuring principle: ZrO<sub>2</sub>-based multilayer sensor with integrated heater and 3 oxygen pumps
- › Triple output signal NO<sub>x</sub>, binary  $\lambda$ , linear  $\lambda$  or O<sub>2</sub> concentration
- › Supply voltage: 12 V or 24 V
- › Data link: CAN 2.0 or SAE-J-1939
- › Operating gas temp.: 100°C up to 800°C

## Smart NO<sub>x</sub> Sensor Gen 4.0P



NO<sub>x</sub> measurement, upstream or downstream SCR. Optimizes urea injection.

### Benefits

- › Real time high accuracy measurement
- › Sensor performance independent of catalyst or ECU supplier and engine management system
- › Modular "Stand-alone" NO<sub>x</sub> sensor enabling EU/US/Japan emission standards compliance

### Technical Information

- › Measuring principle: ZrO<sub>2</sub>-based multilayer sensor with integrated heater and 3 oxygen pumps
- › Triple output signal NO<sub>x</sub>, binary  $\lambda$ , linear  $\lambda$  or O<sub>2</sub> concentration
- › Supply voltage: 12 V or 24 V
- › Data link: CAN 2.0
- › Operating gas temp.: 100°C up to 800°C

## Temperature Sensor EGR



Temperature measurement in EGR system, EGR bypass valve function diagnostic and thermal protection.

### Benefits

- › Temperature measurement of EGR systems
- › Connector design concept for temperatures up to 450°C
- › Resistant to exhaust gases and other relevant chemicals at EGR applications
- › Robust stainless steel cup

### Technical Information

- › RTD or NTC sensor technology
- › Different Pt curves possible (Pt200, Pt1000)
- › Measuring tolerance: +/- 7°C over lifetime
- › Response time (T63): < 13 sec. at air speed 10 m/s
- › Temperature range: -40°C up to +450°C; up to +600 °C (peak 60 sec.)

## Temperature Sensor High Multiple

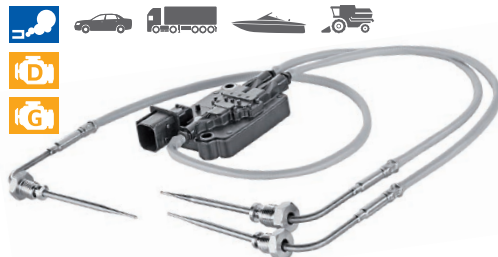

Temperature acquisition for closed-loop after-treatment control (DPF, SCR, DeNO<sub>x</sub>/LNT).

### Benefits

- › Smart sensor with digital output, high accuracy
- › Stable signal over lifetime (ageing compensation)
- › High temperature robustness
- › Fast response due to small thermal inertia
- › High resolution of temperature signal

### Technical Information

- › Thermocouple sensor technology, Type N
- › Response time: 7 s at 10 m/s flow (4 s at 20 m/s)
- › Sensing temp.: -40°C up to +1,000°C
- › Working temp. electronics: -40°C up to +140°C
- › Accuracy: < 500°C +/- 5°C over lifetime  
> 500°C +/- 1% over lifetime
- › Supply voltage: 12 V or 24 V DC (30 mA)/CAN;  
5 V DC (< 20 mA)/SENT

## Drivetrain Efficiency Solutions

### Turning Force into Driving Comfort.

Automatic transmissions can make a major contribution to vehicle efficiency and to the overall driving experience. The transmission creates the connection between the engine and the wheel. Therefore, a drive can only be as good as its transmission.

The power transmission comfort and efficiency depend greatly on the transmission control unit. When does the vehicle change gears, and how quickly does it do so? How are vibrations dampened? When is the engine shut off? Is electric power integrated? Is it recuperated? How can force be transmitted to the wheels as efficiently and seamlessly as possible? Highly integrated controllers with mechanical components (hydraulics) are delivering ever increasing performance today, even in narrow installation spaces and in extremely hot and aggressive environments. Ten years and longer, 300,000 km and more.

More and more compact solutions with new substrates, new manufacturing processes and new component generations are also creating space for the additional integration of electric motors into the transmission. This is how you turn force into driving comfort.



## Electric Fuel Pump - EC



In-tank fuel pump with brushless electronically commutated (EC) motor.

- Benefits**
- › Improved quality, reliability, and durability (less parts, no commutation wear)
  - › Higher efficiency
  - › Electromagnetic compatibility
  - › Body born noise reduction
- Technical Information**
- › Gerotor and turbine pump principles
  - › Pressure: Up to 700 kPa
  - › Flow, typ.: 330 l/h at 500 kPa
  - › Efficiency, typ.: 35%
  - › Size: 38 mm, 43 mm, 50 mm
  - › Media: Diesel (incl. RME), Gasoline (up to E100)

## Electric Fuel Pump - DC

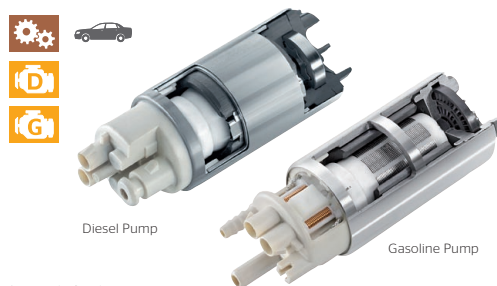

In-tank fuel pump with brush-type direct current (DC) motor.

- Benefits**
- › Most cost-effective solution for non-electronically regulated systems
  - › Stand-alone (electronics not required)
- Technical Information**
- › Gerotor and turbine pump principles
  - › Pressure: Up to 700 kPa
  - › Flow, typ.: 230 l/h at 500 kPa
  - › Efficiency, typ.: 30%
  - › Size: 28 mm, 38 mm, 43 mm
  - › Media: Diesel (incl. RME), Gasoline (up to E100)

## Fuel Delivery Module for Entry Level Vehicles



Flange referenced gasoline module.

- Benefits**
- › Very cost effective solution due to high flange integration
  - › Suitable for compact tanks with low flow requirements
  - › Also applicable for two-wheelers and recreational vehicles

- Technical Information**
- › Low module weight
  - › Integrated vent valve
  - › Serviceable elements

## Fuel Delivery Module for High-End Applications

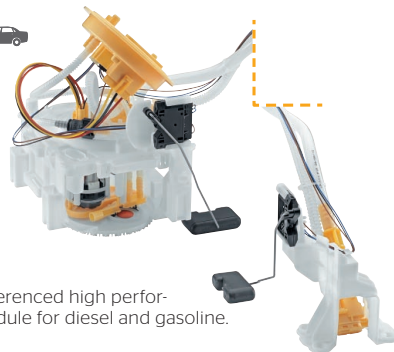

Bottom referenced high performance module for diesel and gasoline.

- Benefits**
- › Developed for high performance vehicles
  - › Applicable for complex tank geometries
  - › Multiple jet-pump and fuel level sensor solutions
  - › Dual pump configurations

- Technical Information**
- › Brushless EC pumps or brushed-type DC pumps
  - › Hydraulic performance: >280 l/h at 6.5 bar

## Fuel Delivery Module for Standard Applications



In-tank Fuel Delivery Module for diesel and gasoline with the opportunity to integrate various functions.

### Benefits

- › Cost effective modular design to cover various customer requirements
- › Constant flow or demand regulated

### Technical Information

- › Brushless EC pumps or brushed-type DC pumps
- › Optional integrated: Fuel level sensor, filter, pressure regulator, electronics, vent valves, and tank leakage detection sensor

## Fuel Level Sensor with an Open Contact System



Cost effective sensor with open contact system.

### Benefits

- › Redundant contacts
- › Various contact materials for different technical requirements and market specific fuel compositions

### Technical Information

- › Measuring range: Angle up to 100°
- › Operating current: 1 up to 20 mA
- › Resolution: 1.25 degree / pad
- › Max. resistor tolerance: +/-1%
- › Operating temperature: -40°C up to +80°C

## Fuel Level Sensor with a Sealed Contact System

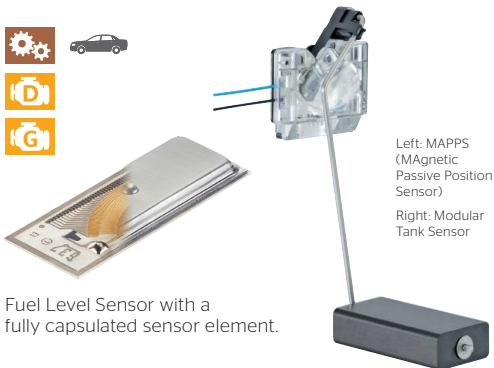

Left: MAPPs (Magnetic Passive Position Sensor)  
Right: Modular Tank Sensor

Fuel Level Sensor with a fully encapsulated sensor element.

- Benefits**
- › Hermetically sealed contacts assure robust protection against corrosion
  - › Longer life time (>10 million cycles) because of a wear free measurement system
  - › Electromagnetic compatibility

- Technical Information**
- › Measuring range: Up to 90°
  - › Operating current: Up to 20 mA
  - › Resolution: 1.7 degree / pad
  - › Max. resistor tolerance: +/-1%
  - › Operating temperature: -40°C up to +80°C

## Fuel Delivery Controller

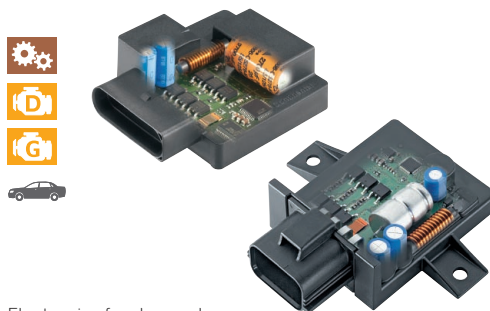

Electronics for demand regulation of fuel delivery modules.

- Benefits**
- › Reduced consumption of electrical energy
  - › Enhanced lifetime
  - › Reduced vibration and noise level
- Technical Information**
- › Stand-alone device or integrated in fuel module
  - › Operating voltage: 6 V up to 16 V
  - › Electrical power: 100 W up to 200 W
  - › Operating temperature: -40°C up to +85°C
  - › Control input / output signal: PWM
  - › Degree of protection: IP6K7 and IP44

## Tank Domain Controller

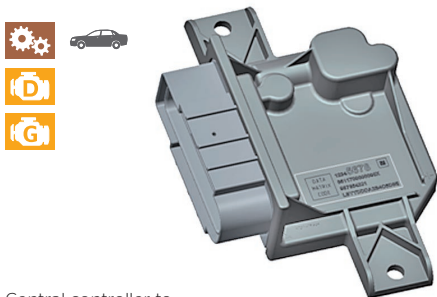

Central controller to sensors and actuators in tank domain.

### Benefits

- › Reduced consumption of electrical energy
- › Enhanced lifetime
- › Reduced vibration and noise level
- › Processing of other signals (e.g. fuel level sensor, pressure sensor, leakage detection)

### Technical Information

- › Operating voltage: 6 V up to 16 V
- › Electrical power: 100 W up to 200 W
- › Operating temperature: -40°C up to +85°C
- › Control input/output signal: CAN
- › Degree of protection: IP6K7 and IP44

## Position Sensor Linear Contactless

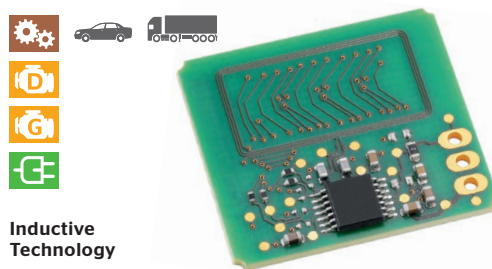

### Inductive Technology

Sensor mainly used for park/no park, clutch master cylinder, linear actuators, PRND, fork position sensor.

### Benefits

- › Metallic target (Al, Fe, etc.), no magnet needed
- › Immune versus low frequency magnetic field (electric motor, starter current, etc.), no pollution by iron particles
- › ASIC available
- › Compliant with ISO 26262 (safety requirement)

### Technical Information

- › Measuring range: 6 mm up to 60 mm
- › Overall accuracy: +/- 2%
- › Air gap: Up to 5 mm
- › Linearity: < +/- 1% full scale
- › Operating temp. range: -40°C up to +160°C
- › No hysteresis
- › Output signal: Analog, PWM or SENT
- › Flat or cylindrical shape targets

## Position Sensor Rotary Contactless



### Inductive Technology

For PRND, rotary valve position (EGR, ETC, ACV, water valve, thermal management), general purpose rotary actuators.

- Benefits**
- › Metallic target, no magnet
  - › Immune to low frequency magnetic field, no pollution by iron particles
  - › Single or redundant configuration
  - › ASIC available
  - › Compliant with ISO 26262 (safety requirement)

- Technical Information**
- › Measuring range: Up to 360°
  - › Overall accuracy: +/- 1%
  - › Air gap: Up to 5 mm
  - › Linearity: < +/- 1% full scale
  - › No hysteresis
  - › Operating temp. range: -40°C up to +160°C
  - › Output signal: Analog, PWM or SENT
  - › End of shaft or off axis configuration

## Position Sensor Rotary or Linear Contactless

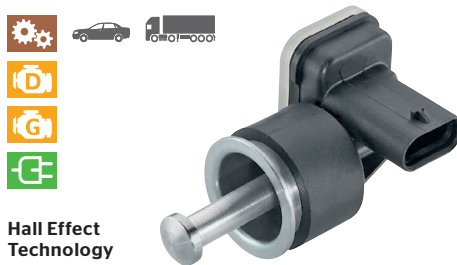

### Hall Effect Technology

Rotary used for PRND, rotary valve position, GPA. Linear used for gear neutral, all gear sensors, CMC, pedal, etc.

- Benefits**
- › Small sensor size
  - › Through aluminum wall measurement
  - › High air gap
  - › Compatible with ferrite magnets
- Technical Information**
- › Overall accuracy: Min. +/- 2%
  - › Target: NdFeB, ferrite magnet
  - › Rotary measuring range: Up to 360°
  - › Linear measurement: Up to 60 mm
  - › Air gap: Up to 11 mm
  - › Operating temp. range: -40°C up to +150°C according to application
  - › Operating voltage: 5 V +/- 0.5 V
  - › Output signal: Analog, PWM, SPI or SENT
  - › X-Y measurement possible

## Twin Drive Pump

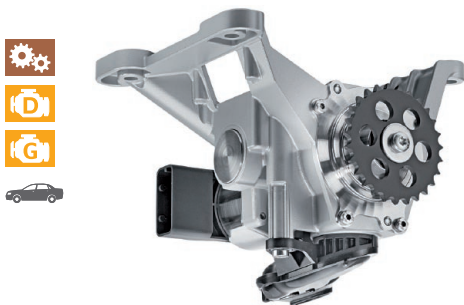

Small, efficient fixed displacement pump to cover the hydraulic base load.

- Benefits**
- › Electrical boost function to cover peak loads and engine-off functions
  - › Operates simultaneously or separate in mechanical and/or electrical mode
  - › Highest overall efficiency in both operation modes
  - › Combined mechanical and electrical driven main pump
- Technical Information**
- › Electronically commutated BLDC motor with/without sensor
  - › Electric power: -150 W up to 500 W
  - › BLDC commutation, depending on customer requirement
  - › Vane-type pump

## Smart Position Sensor Cover

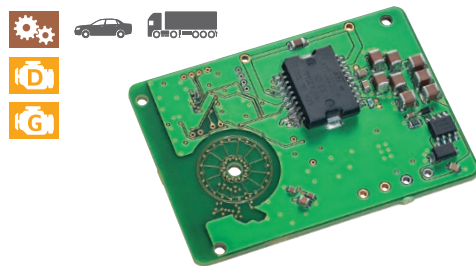

Smart Position Sensor used for controlling general purpose electrical actuators.

- Benefits**
- › Inductive position sensor with ASIC
  - › Immune to low frequency magnetic fields (metal target, no magnet)
  - › H-bridge driver for DC motor (ASIC)
  - › Microcontroller for position control
  - › High temperature operation
- Technical Information**
- › Sensor measuring range: Up to 360°
  - › Sensor accuracy: +/-1%, no hysteresis
  - › End of shaft or off-axis sensor configuration
  - › H-bridge driver with 4 Amp current capability
  - › 16-bit MCU with embedded PID control
  - › Operating temperature: Up to 140°C
  - › Built in protections: O/L, O/T, O/V, U/V
  - › CAN, LIN or PWM interface

## Control Unit for Double Clutch Transmission

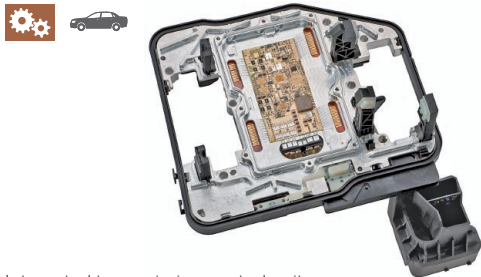

Integrated transmission control unit for dry 7-speed Double Clutch Transmission.

- Benefits**
- › Mechatronic module integrated in the gearbox
  - › Direct connection of actuators to the control unit
  - › Higher reliability of the electronics due to the reduced number of internal connections
  - › Considerable weight reduction due to integration
  - › Optimized driving comfort and fuel consumption
- Technical Information**
- › Substrate: Bare-Die High-Density Interconnect
  - › Operating temperature:  $-40^{\circ}\text{C}$  up to  $+140^{\circ}\text{C}$
  - › 32-bit microprocessor
  - › Control of BLDC motor of oil pump
  - › Sensors: 4 gearshift position, 2 clutch position, 2 speed, 1 pressure, 1 temperature
  - › Actuators (Control): 8 x PWM proportional solenoids

## Control Unit for Double Clutch Transmission



Integrated transmission control unit for wet 7-speed Double Clutch Transmission (hydraulically controlled).

- Benefits**
- › Mechatronic module integrated in the gearbox
  - › Short links to sensor systems and actuating elements
  - › Reduced harness length
- Technical Information**
- › Substrate: LTTTC (Low temperature co-fired ceramics) substrate for electronic components
  - › Operating temperature:  $-40^{\circ}\text{C}$  up to  $+145^{\circ}\text{C}$
  - › 32-bit microcontroller
  - › Sensors: 4 gearshift position, 2 speed, 2 pressure, 1 temperature
  - › Actuators: 11 closed-loop controlled valves

## Control Unit for Double Clutch Transmission

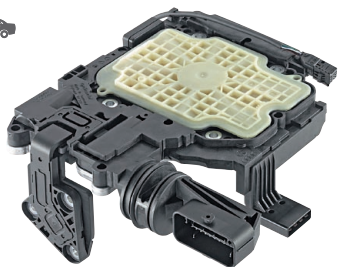

Integrated transmission control unit for wet 7-speed Double Clutch Transmission.

- Benefits**
- › Efficient design and packaging, reduced wiring, and weight
  - › Short links to sensor systems and actuating elements
  - › Full integration of TCU, sensors, and solenoids
  - › For use in front, rear, all-wheel-drive, and hybrid applications

- Technical Information**
- › Substrate: Bare-Die High-Density Interconnect
  - › Operating temperature: -40°C up to +148°C
  - › 2 x 32-bit microcontroller
  - › Sensors: 2 temperature, 1 motor speed, 2 various external sensors
  - › Actuators: Control of 9 solenoids (+ 1 optional)
  - › Functional safety level ASIL D

## Control Unit for Double Clutch Transmission

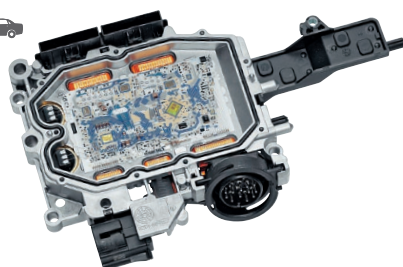

Integrated transmission control unit for wet 7-speed Double Clutch Transmission (hydraulically controlled).

- Benefits**
- › AWD applications, longitudinal installation of the engine
  - › Fully integrated control unit contains all electronic components
  - › Improved shifting performance and comfort

- Technical Information**
- › Substrate: Ceramic substrate technology
  - › Operating temperature: -40°C up to +145°C
  - › 32-bit microcontroller
  - › Vibrations up to 20 g
  - › Sensors: Temperature, pressure, speed, gear position
  - › Actuators: 11 solenoids
  - › Functional safety level: ASIL C

## Control Unit for Double Clutch Transmission

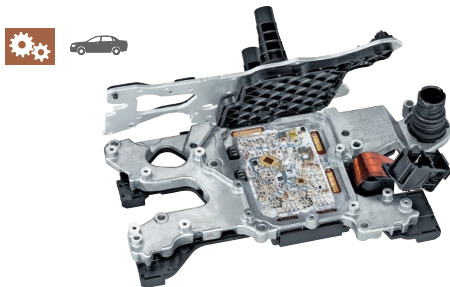

Integrated transmission control unit for wet 7-speed Double Clutch Transmission (hydraulically controlled).

- Benefits**
  - › Integrated module directly mounted in transmission
  - › Short links to sensor systems and actuating elements
  - › Small space requirements
- Technical Information**
  - › Substrate: Thickfilm ceramic substrate technology
  - › Operating temperature: -40°C to +145°C
  - › 32-bit microcontroller
  - › Sensors: 4 gearshift, 1 parking lock, 3 speed, 2 temperature, 2 pressure
  - › Actuators (Control): 10 solenoids, 1 BLDC-motor for oil pump
  - › Functional safety level: ASIL C

## Control Unit for Double Clutch Transmission

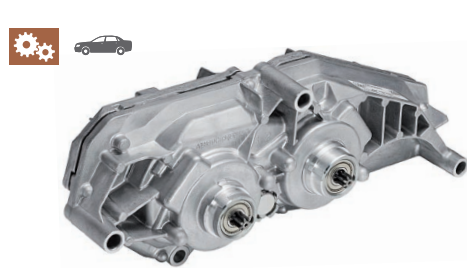

Mechatronic actuator module for dry 6-speed Double Clutch Transmission.

- Benefits**
  - › Directly attached to the gearbox
  - › Includes 2 BLDC motors
  - › Higher reliability and accuracy of control
  - › Flexible transmission design in regards to package
  - › High dynamics of integrated gear shift actuators
- Technical Information**
  - › Substrate: PCB technology
  - › Operating temperature: -40°C up to +115°C
  - › 32-bit microcontroller
  - › Sensors: 2 temperature, 2 shift motor position
  - › Actuators: 2 BLDC motors for gear changing
  - › Integrated control for 2 external BLDC motors for clutch control
  - › Functional safety level: ASIL C

## Control Unit for Double Clutch Transmission

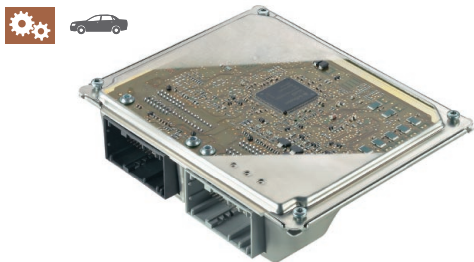

External transmission control unit for wet-clutch 7-speed Double Clutch Transmission.

- Benefits**
- › Stand-alone module
  - › Simple integration into vehicle
  - › Enables selection of different shifting characteristics
  - › Improved shifting comfort
- Technical Information**
- › Substrate: PCB technology
  - › Operating temperature: -40°C up to +85°C
  - › 32-bit microcontroller
  - › Sensors: 3 pressure (analog), 2 temperature (analog), 4 position (PWM), 3 speed (frequency)
  - › Actuators: 9 solenoids (7 closed loop + 2 open loop)

## Control Unit for Double Clutch Transmission

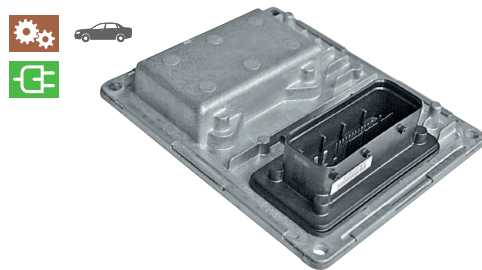

Universal transmission control unit for 7-speed Double Clutch Transmission for hybrid vehicles.

- Benefits**
- › Supports electromechanical actuation and smart actuators
  - › External module or directly mounted to transmission
- Technical Information**
- › Substrate: PCB-FR4
  - › Operating temperature: -40°C to +105°C
  - › 32-bit microcontroller
  - › Sensors: 2 x 3 hall sensors
  - › Actuator outputs: 2 drivers for EC motor, 2 HS driver function
  - › Communication: CAN and LIN

## Control Unit for Double Clutch Transmission



Transmission control unit platform for Double Clutch Transmission.

- Benefits**
- › Platform control unit for flexible use
  - › Stand-alone or attached-to concepts
  - › Cost and weight optimized solution
  - › Optimized for use with integrated sensor cluster

- Technical Information**
- › Substrate: PCB technology
  - › Operating temperature: -40°C up to +125°C
  - › 32-bit microcontroller
  - › Up to 12 closed-loop current control outputs
  - › Control of BLDC motor

## Control Unit for Double Clutch Transmission

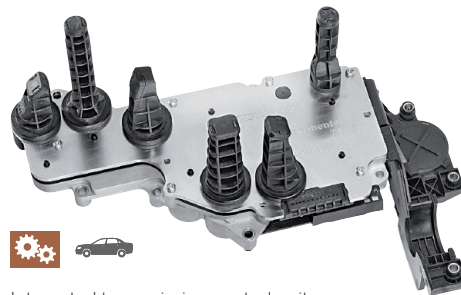

Integrated transmission control unit for wet 6-speed Double Clutch Transmission.

- Benefits**
- › Mechatronic module integrated in the gearbox
  - › Directly mounted on valve body
  - › Weight reduction due to integration
  - › Integrated sensors / signal processing
  - › Improved shifting performance and comfort

- Technical Information**
- › Substrate: Ceramic
  - › Operating temperature: -40°C up to +140°C
  - › 32-bit microcontroller
  - › Sensors: 2 speed, 4 linear position, 2 temperature, 2 pressure, 1 transmission range, 1 direction, 2 speed
  - › Actuators: 9 solenoids (4 prop. + 5 on/off)
  - › Functional safety level: ASIL C

## Control Unit for Automatic Transmission

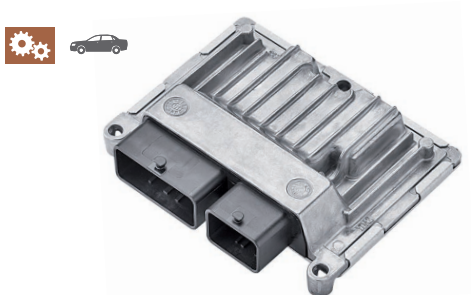

External transmission control unit for 6-speed Automatic Transmission.

- Benefits**
- › Compact module with small size and low weight
  - › Flexible mounting positions in engine or passenger compartment
  - › Robust design with aluminum housing

- Technical Information**
- › Substrate: PCB technology
  - › Operating temperature: -40°C up to +105°C
  - › 32-bit microcontroller
  - › Communication: CAN
  - › Safety level: ASIL B

## Control Unit for Stepped Automatic Transmission

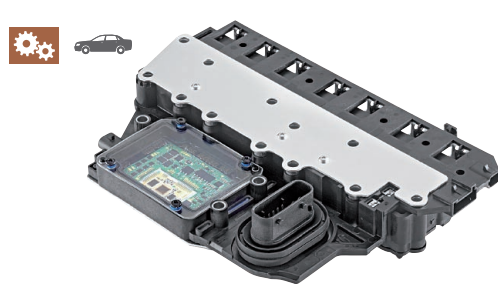

Integrated electro-hydraulic transmission control module for 6-speed Stepped Automatic Transmission.

- Benefits**
- › Integrated TCU including manifold and solenoids
  - › Compact module with small size and low weight
  - › Higher reliability and reduced number of connectors
  - › Smooth shifting of gears

- Technical Information**
- › Substrate: LTCC and FR4 technology
  - › Operating temperature: -40°C up to +140°C
  - › 32-bit microcontroller with external flash memory
  - › Actuators: 7 integrated solenoids
  - › Integrated hydraulic filter elements and manifold
  - › Plastic mechatronic with integrated lead frames

## Control Unit for Stepped Automatic Transmission

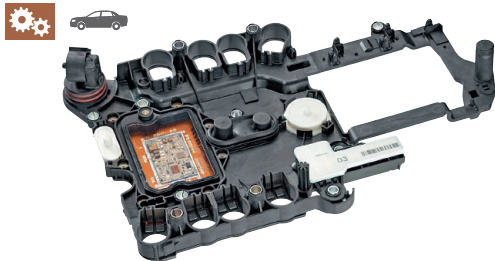

Integrated control unit for 7-speed Stepped Automatic Transmission.

### Benefits

- › Mechatronic module
- › Assembled on valve body of gear box
- › Short links to sensors and actuating elements
- › Improved performance characteristics

### Technical Information

- › Substrate: Ceramic
- › Operating temperature: up to +140°C
- › 32-bit microcontroller
- › Sensors: 3 speed, 1 temperature, 1 linear position (TRS)
- › Actuators: 8 power outputs for solenoids

## Control Unit for Stepped Automatic Transmission

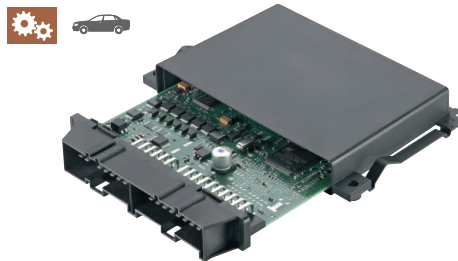

Transmission control unit for 5-speed Stepped Automatic Transmission for rear-wheel drive vehicles.

### Benefits

- › Mounted in engine compartment
- › Simple integration into vehicle
- › Cost and weight optimized

### Technical Information

- › Substrate: PCB technology
- › Operating temperature: -40°C up to +140°C
- › 16-bit microcontroller
- › Actuators: 2 control valves for hydraulic of transmission, 3 control valves for gearshift, 1 valve for bypass converter
- › Power output for 6 electro-mechanical hydraulic valves

## Control Unit for Stepped Automatic Transmission

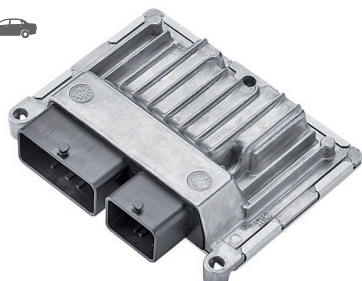

Stand-alone control unit for 6-speed Stepped Automatic Transmission.

- Benefits**
- › Compact module with small size and low weight
  - › Flexible mounting positions, engine or passenger compartment
  - › Improved shifting performance and smooth gear changes

- Technical Information**
- › Substrate: PCB technology
  - › Operating temperature: -40°C up to +105°C
  - › 32-bit microcontroller
  - › Communication: CAN
  - › 2 power supply outlets for solenoids

## Control Unit for Continuously Variable Transmission

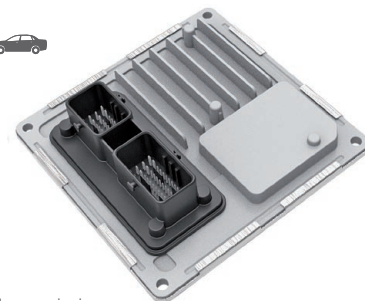

External transmission control unit for Continuously Variable Transmission (CVT).

- Benefits**
- › External module placed in passenger or engine compartment
  - › Stand-alone concept
  - › Reduced time-to-market due to platform technology

- Technical Information**
- › Substrate: PCB technology
  - › Operating temperature: -40°C up to +95°C
  - › 32-bit microcontroller with external flash memory
  - › Sensors: 5 gearshift position, 3 gearlever control, 3 speed, 2 pressure, 1 temperature
  - › Actuators: 6 PWM proportional solenoid
  - › Closed-loop control

## Universal Transmission Control Unit



Universal transmission control unit for different types of transmissions.

- Benefits**
- › Stand-alone TCU, chassis-mounted
  - › Flexible module with various inputs and actuator outputs
  - › Universal use for different types of transmissions (AT, CVT, AMT, etc.)

- Technical Information**
- › Substrate: PCB technology
  - › Operating temperature: -40°C up to +105°C
  - › 32-bit microcontroller
  - › Sensors: No sensor integrated in TCU
  - › Actuators: 10 PWM proportional controlled solenoids

## Universal Transmission Control Unit Platform

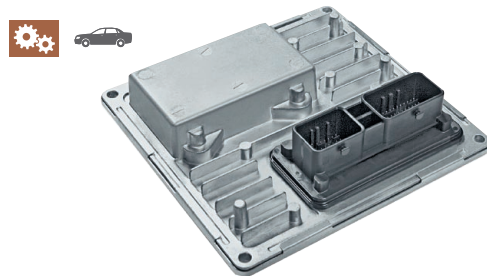

Universal transmission control unit platform for DCT, CVT, AMT, and Step-AT transmissions.

- Benefits**
- › External module placed in passenger or engine compartment
  - › Stand-alone concept
  - › Cost and weight optimized
  - › Reduced time-to-market due to platform technology

- Technical Information**
- › Substrate: PCB technology
  - › Operating temperature: -40°C up to +95°C
  - › 32-bit microcontroller with internal flash memory
  - › Sensors: 4 speed, 4 gear lever position, 2 pressure, 4 gear shift position, 2 temperature
  - › Actuators: 8 PWM proportional solenoid controls
  - › Closed-loop control
  - › BLDC motor control

## Electronic Control Unit for Limited Slip Coupling

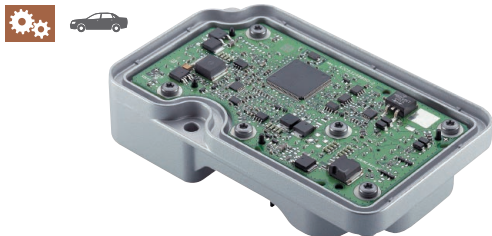

Control unit for limited slip coupling and AWD applications.

### Benefits

- › Unit directly attached to 4WD transfer case
- › Control of valve and feeder pump to change torque distribution between front and rear axle

### Technical Information

- › Substrate: PCB technology
- › Operating temperature: -40°C up to +120°C
- › 16-bit microcontroller
- › Sensors: 1 pressure sensor, 1 oil temperature sensor
- › Actuators (Control): PWM control of 2 proportional valves, 1 feeder pump motor

## Universal Control Unit for Powertrain Applications

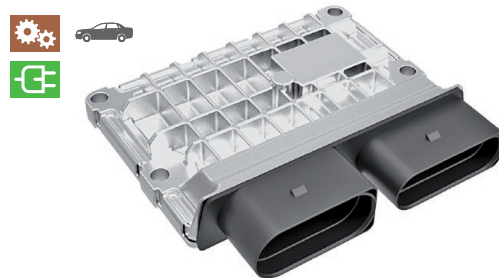

Universal control unit (CU) for brushless DC (BLDC) motors.

### Benefits

- › CU can be used as a controller for e-clutch or e-axis actuators, as well as for electronic central shifter for hybrid modules
- › Stand alone module
- › Compact and lightweight design

### Technical Information

- › Substrate: PCB-FR4 technology
- › Operating temperature: -40°C up to +125°C
- › 32-bit microcontroller
- › Sensors: 2 x 3 hall sensors (external)
- › Actuators: 1 B6 driver for EC-motor (external)
- › Communication: CAN

## Transfer Case Actuator

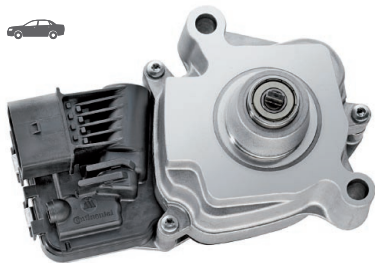

4WD/AWD control unit with integrated motor for wet transfer cases.

- Benefits**
- › Directly attached to the transfer case
  - › Integration of ECU, brushless DC motor, and sensors in one mechatronic actuator unit
- Technical Information**
- › Substrate: PCB technology
  - › Operating temperature: -40°C up to +140°C (Transfer Case)
  - › 16-bit microcontroller
  - › Sensors: 1 angle position sensor
  - › Actuators: 1 integrated BLDC-Motor

## Multi Position Linear Actuator

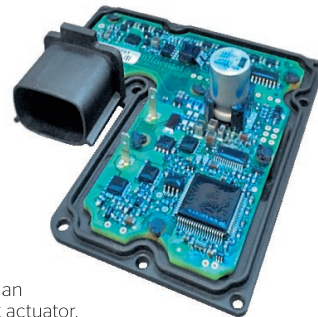

Control unit for an axle disconnect actuator.

- Benefits**
- › Mounted on Power Transfer Unit (PTU) on the axle
  - › Covers heat stake interface to PCB
  - › Motor terminal blades on PCB
- Technical Information**
- › Substrate: FR4
  - › Operating temperature: -40°C up to +125°C
  - › 16-bit microcontroller
  - › Sensors: 8 linear hall effect, 1 rotational encoder, 1 temperature
  - › Actuators: Control of 1 brushed DC motor

## Direct Shift Module

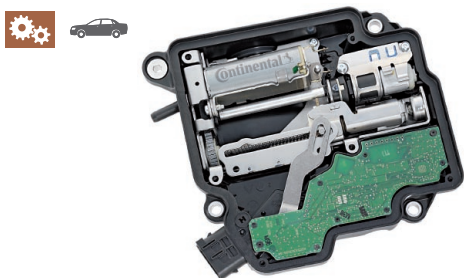

Shift-by-Wire Actuator for the PRND lever of an automatic transmission.

- Benefits**
  - › Shift-by-Wire module attached outside of the gearbox
  - › Module is compact in size compared to conventional PRND shift-levers. This creates more space for other CUs
- Technical Information**
  - › Substrate: PCB technology
  - › Operating temperature:  $-40^{\circ}\text{C}$  up to  $+120^{\circ}\text{C}$  (peak  $140^{\circ}\text{C}$ )
  - › 16-bit microcontroller
  - › Sensors: Lever angle, temperature, eccentric shaft
  - › Actuators: 2 motors for PRND shift and emergency shift to P
  - › Communication via CAN

## Sensorcluster for Wet Double Clutch Transmissions

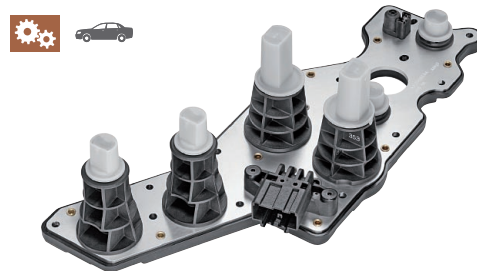

Transmission-integrated sensorcluster for Double Clutch Transmission.

- Benefits**
  - › Internal module mounted in the transmission
  - › Can be used as stand-alone (with various TCUs)
  - › Cost and weight optimized solution
- Technical Information**
  - › Operating temperature:  $-40^{\circ}\text{C}$  up to  $+150^{\circ}\text{C}$
  - › Sensors: 4 gearshift position, 2 speed, 1 temperature
  - › Provides sensor signals for the TCU

## Smart Actuator Platform

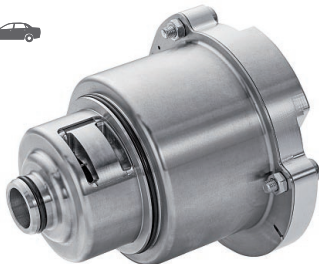

Modular platform for peripheral devices for transmissions.

### Benefits

- › SmAP can be designed as a clutch actuator, a pump for transmission lubrication or transmission cooling
- › Flexible actuation platform for transmissions
- › Reduced time to market due to standardised components
- › Supports electrification strategy of powertrains

### Technical Information

- › Voltage rating: 4.5 V up to 24 V
- › Power: 80 W up to 500 W
- › Operating temperature: -40°C up to +140°C
- › Sensor or sensorless control
- › Functional safety level: up to ASIL C

## Control Unit for Automated Manual Transmission (CV)



External transmission control unit for Automated Manual Transmission for light/medium duty commercial vehicles.

### Technical Information Benefits

- › External control unit, transmission-mounted
- › Robust design, high reliability
- › Substrate: Flex FR4 PCB
- › Operating temperature: -40°C up to +105°C
- › 32-bit microcontroller
- › Sensors: 3 position, 3 speed
- › Actuators: 4 electric motors
- › Communication: CAN

## Control Unit for Double Clutch Transmission (CV)

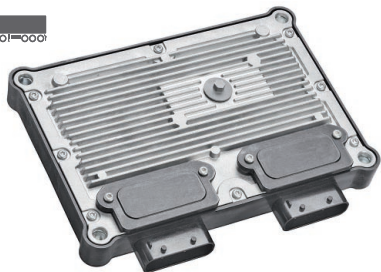

Transmission control unit for wet 7-speed Double Clutch Transmission for medium duty commercial vehicles.

- Benefits**
- › External control unit for medium duty commercial vehicles
  - › Reduced complexity and length of the wiring harness
  - › Supports creep mode and hill-start assist
  - › Supports efficient gear shifting strategies
- Technical Information**
- › Substrate: PCB technology
  - › Operating temperature: -40°C up to +125°C
  - › 32-bit microprocessor with 4 mb of RAM
  - › Control of:
    - 4 gearshifts and positions
    - 2 safety valves
    - main oil pressure
    - cooling oil pressure

## Electronic Clutch Actuator (CV and Off-Highway)

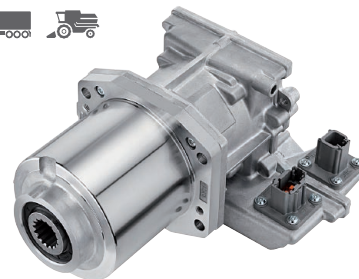

Electronic clutch actuator for commercial vehicles.

- Benefits**
- › Rugged design (mechanical shock: up to 50 G)
  - › High thermal stability
  - › 17° angle within 250 ms
  - › Refined clutch actuation, enables creep mode
- Technical Information**
- › Electronics:
    - Substrate: PCB technology
    - 12 V/24 V
    - 32-bit microcontroller
    - CAN communication
  - › Motor:
    - 250 W 3-phase BLDC motor
    - 1200 RPM
    - 2.5 Nm at 1000 RPM torque
  - › General:
    - Operating temp.: -40°C up to +121°C
    - 100:1 planetary gear set
    - Integrated position sensor

Continental Automotive GmbH  
Powertrain Division  
Siemensstrasse 12  
93055 Regensburg · Germany  
Phone + 49 941 790-0  
[www.continental-automotive.com](http://www.continental-automotive.com)



#### Legal notice

The information provided in this brochure contains only general descriptions or performance characteristics, which do not always apply as described in case of actual use or which may change as a result of further development of the products. This information is merely a technical description of the product. This information is not meant or intended to be a special guarantee for a particular quality or particular durability. An obligation to provide the respective characteristics shall only exist if expressly agreed in the terms of contract. We reserve the right to make changes in availability as well as technical changes without prior notice.

© Continental Automotive GmbH

**Continental**   
The Future in Motion