



Premium performance



High load capacity



Extreme temperatures



Start-stop battery with modern EFB technology

The Continental Enhanced Flooded Battery (EFB) is the right choice for vehicles with entry-level start-stop systems without braking energy recovery. It has impressive cold-start performance and enables both low-resistance and rapid charging and discharging.

All the advantages at a glance

- › Perfect for vehicles with entry-level start-stop system
- › For demanding climatic and weather conditions: 115% Cold Cranking Amps (CCA)*
- › Long life of at least two times more cycles*
- › High deep-discharge capability
- › 20% less energy consumption and greenhouse emissions*
- › Charge monitoring indicator (Magic Eye)
- › Extreme safety: 100% leak-proof
- › Maintenance-free – saves labor and costs
- › Two-year warranty

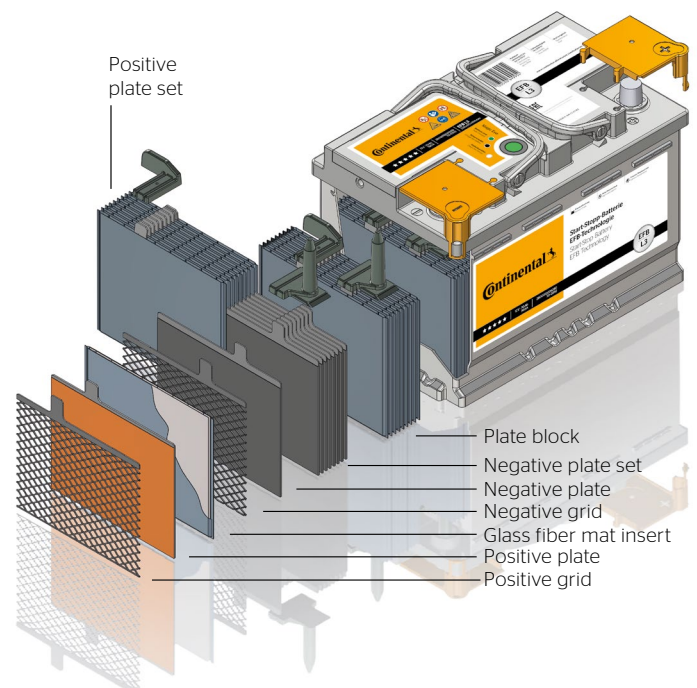

EFB technology: Battery construction

* compared with conventional batteries

Technical information

Article number	Type	Box	Dimensions LxWxH [mm]	Weight [kg]	Voltage [V]	Capacity [Ah]	Cold discharge test current [A]
2800012000280	EFB	L2	242 x 175 x 190	17.0	12	60	560
2800012004280	EFB	LB3	278 x 175 x 175	17.9	12	65	650
2800012001280	EFB	L3	278 x 175 x 190	20.0	12	70	650
2800012005280	EFB	LB4	315 x 175 x 175	20.0	12	75	730
2800012002280	EFB	L4	315 x 175 x 190	22.4	12	80	730
2800012003280	EFB	L5	353 x 175 x 190	25.1	12	95	800

Technical details

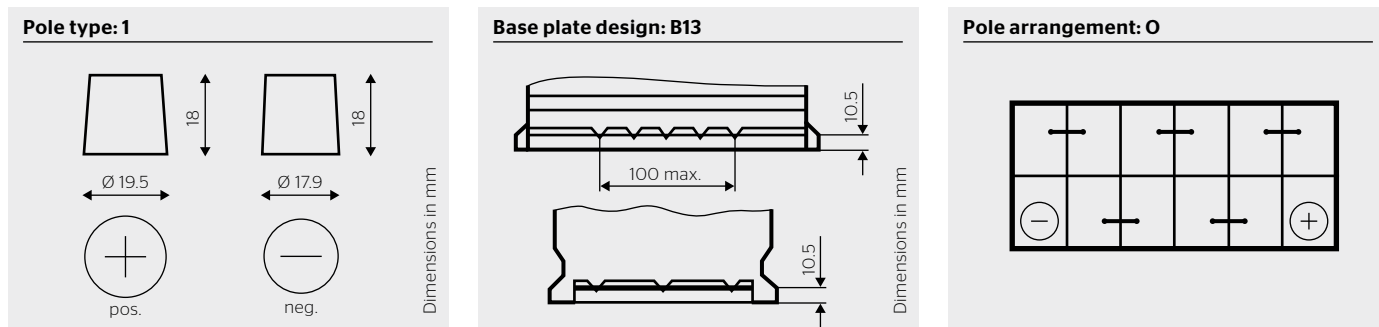

Ordering information

Article number	Product description	EAN number	No off / pallet	Weight [kg] / pallet	Packing unit	
2800012000280	Start-stop battery EFB L2	60/560	4103590680198	54	940	1
2800012004280	Start-stop battery EFB LB3	65/650	4103590680235	48	880	1
2800012001280	Start-stop battery EFB L3	70/650	4103590680204	46	939	1
2800012005280	Start-stop battery EFB LB4	75/730	4103590680242	42	862	1
2800012002280	Start-stop battery EFB L4	80/730	4103590680211	40	916	1
2800012003280	Start-stop battery EFB L5	95/800	4103590680228	36	922	1

Continental batteries compared

Criteria	EFB battery	AGM battery	Starter battery
Vehicle type	Start-stop	Start-stop and recuperation	Without start-stop (gasoline/diesel vehicles)
Cycle stability	>> 200%*	>> 300%*	100%
Technology	EFB - Enhanced Flooded Battery	AGM - Absorbent Glass Mat	Lead-acid
Maintenance	Maintenance-free	Maintenance-free	Low maintenance
Number of battery types	6	3	10
Cold start capacity	115%*	135%*	100%
Specification	OE-equivalent	OE-equivalent	OE-equivalent
Quality level	OEM quality	OEM quality	OEM quality
Suitable for recuperation	-	Yes	-
Deep discharge	Good	Very good	-
Vibration protection	Good	Very good	-
Charge acceptance	Good	Very good	-
Charge indicator (Magic Eye)	Yes	-	Yes
Leak proof	-	Yes	Yes
Warranty	2 years	2 years	2 years

* compared with conventional batteries



Continental Aftermarket & Services GmbH
 Sodener Straße 9 · 65824 Schwalbach · Germany
 T. +49 69 7603-0
 info@continental-aftermarket.com
 www.continental-aftermarket.com