



# FDR1060 Wheel Balancer

## Operation & Maintenance Manual

## Manufacturer

Continental Automotive Trading UK Ltd  
36 Gravelly Industrial Park  
Birmingham  
B24 8TA

## Sales

Tel: 0121 725 1400  
Email: [salesorders@continental-corporation.com](mailto:salesorders@continental-corporation.com)

## Technical Services

Tel: 0121 725 1366  
Email: [uksupport@continental-corporation.com](mailto:uksupport@continental-corporation.com)

## Document Information

Document Revision	Title	Operation & Maintenance Manual
	Type	FDR1060
	Version	325081 Iss 1
	Date	1/5/2023
	History	325083 Iss 1_Initial Draft UK_ Rel 2.1.4 06/19

E & O E. The Company reserves the right to introduce improvements in design or specification without prior notice. The sale of this product is subject to our standard terms, conditions and relevant product warranty.

Table of Contents	
1	Introduction..... 5
2	Intended Use..... 7
3	Safety Rules..... 7
4	Transport & Handling..... 8
5	Unpacking..... 9
6	Installation & Switching on..... 9
7	Installation..... 15
8	Suspension of Use..... 17
9	Environmental Information..... 17
10	Technical Data..... 18
11	Identification Data..... 20
12	Maintenance..... 20
13	Control Panel..... 21
14	Switching the Machine - Diagnostic..... 25
15	Use of the Machine in Normal Mode..... 26
16	Machine Calibration..... 45
17	Optimisation..... 50
18	Hidden Weights Program..... 53
19	Second Operator..... 56
20	Utility Programs..... 57
21	Service Mode..... 61
22	Signals..... 65
23	Electrical System..... 72
24	Diagnostics & Efficiency of Accessories..... 73
25	Fire Prevention..... 74

Machine dimensions

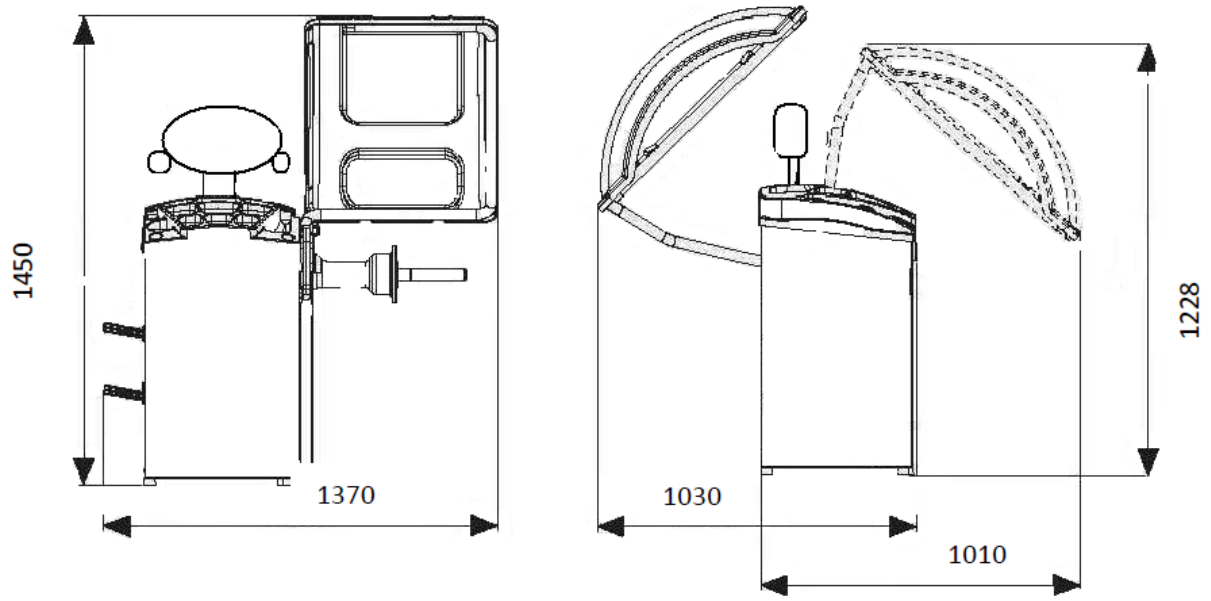

Picture F1.1

## 1 Introduction

Thank you for purchasing a Continental Wheel Balancer. The equipment has been manufactured in accordance with the very best quality principles. Follow the simple instructions provided in this manual to ensure the correct operation and long life of the machine. Carefully read each section of this manual before using the machine. The manufacturer is not responsible for damages and/or injury caused by failure to follow the instructions of this manual.

We also recommend:

- Keep the manual near wheel balancer for easy access;
- Keep the manual in a place protected from dirt;
- Do not damage the manual.

We reserve the right to make any change to products and documentation without notice.

In the manual the following symbols are represented:



Operations that require special attention



Prohibitions



Possible Danger for the operator

## 1.1 Warranty

### 1.1.1 Terms of Warranty and limitations of responsibility

The information in the present manual has been released with the maximum attention, and nothing reported may modify the terms and the general conditions of the contracts of purchase, of leasing or of rental, in which the equipment mentioned in this manual had been acquired, neither it increases in some way the responsibility towards the customer or of bystanders.

### FOR THE READER

The machine remains a working aid to the operator's activity.

Based on evaluations coming both from the unit and the operators visual control of the wheel, supported by his experience, the operator remains the one deciding what to do and is responsible for the final actions on the wheels.

Continental standard terms of warranty apply to this product, in addition the terms below are also in effect.

### 1.1.2 Warranty Duration

From the date of shipment from Continental 36 months

### 1.1.3 Who gives this warranty

Continental Automotive Trading UK Ltd, Unit 36, Gravelly Industrial Park, Birmingham, B24 8TA.

### 1.1.4 Who receives this warranty

The original Purchaser (other than for purpose of resale)

### 1.1.5 What products are covered by this warranty

Any Continental branded tire changer or wheel balancer.

### 1.1.6 What is covered under this warranty

Manufacturer defects due to material and/or workmanship with the exceptions noted below.

### 1.1.7 What is not covered under this warranty

1.1.7.1 Any failure that results from Purchaser's abuse, neglect or failure to operate, maintain or service product in accordance with instructions provided in the owner's manual(s) supplied

1.1.7.2 Any damage caused by using equipment beyond rated capacity and/or capability

1.1.7.3 Items or service normally required to maintain the product, i.e. lubricants, oil, etc.

1.1.7.4 Items considered general wear parts such as rubber or plastic pads/protectors, cutting tips, plastic trays, etc. unless wear or failure is a direct result of manufacturer defect due to material and/or workmanship

1.1.7.5 Any component damaged in shipment or any failure caused by installing or operating equipment under conditions not in accordance with installation and operation guidelines or damaged by contact with tools or surroundings

1.1.7.6 Motor or other component failure caused by rain, excessive humidity, corrosive environments or other contaminants

1.1.7.7 Rusted components due to improper maintenance or corrosive environments

1.1.7.8 Cosmetic defects that do not interfere with product functionality

1.1.7.9 Damage due to incorrect voltage or improper wiring

1.1.7.10 Any incidental, indirect, or consequential loss, damage, or expense that may result from any defect, failure, or malfunction of a product.

1.1.7.11 All electrical components are guaranteed for one year against defects in workmanship and/or materials when the lift is installed and used according to specifications

### 1.2 Responsibilities of Warrantor

Repair or replace with either new or reconditioned unit at Warrantor's option, component and/or unit which is defective, has malfunctioned and/or failed to conform within duration of the warranty period.

### 1.3 Responsibilities of Purchaser

Provide dated proof of purchase and maintenance records.

Use reasonable care in the operation and maintenance of the products as described in the owner's manual.

### 1.4 Repair & Replacement

The Warrantor will perform repair or replacement under this warranty: Repair or replacement will be scheduled and serviced according to the normal work flow at the servicing location, and depending on the availability of replacement parts.

## 2 Intended Use

This manual is an integral part of product.

Read carefully warnings and instructions contained in this manual because they provide important information about SAFE USE and MAINTENANCE.



KEEP WITH CARE THIS MANUAL NEAR THE MACHINE TO FACILITATE ANY CONSULTATION BY OPERATORS.

The wheel balancers have been made to be used in balancing of wheels cars (CAR), off-road vehicles (SUV), motorcycles (MOTO). These wheel balancers are not designed for balancing wheels for transportation vehicles (light or heavy) and for special vehicles (agricultural, forestry, mining, etc). The machines can work on wheels with diameter from 1" to 35" (or from 25 to 890 mm) and width from 2" to 20" (or from 50 to 500 mm). All functions and controls are set through a series of buttons arranged on a panel. The data are displayed on a led display.

## 3 Safety Rules

The wheel balancer must be used exclusively for the purpose it was designed for. Any other use is considered INCORRECT and UNREASONABLE.

The use of wheel balancer is allowed only to authorized and trained personnel.

Do not put objects in the base which may affect the correct operation of wheel balancer.



THE MANUFACTURER IS NOT RESPONSIBLE FOR ANY DAMAGE TO PERSONS OR PROPERTY CAUSED BY UNAUTHORIZED PERSONNEL OR FROM IMPROPER, INCORRECT AND UNREASONABLE USE OF THE WHEEL BALANCER.



THE WHEEL BALANCER SHOULD NOT BE MODIFIED OR TAMPERED WITHOUT PERMISSION OF MANUFACTURER. ANY UNAUTHORIZED MODIFICATION MADE TO THE EQUIPMENT RELIEVES THE MANUFACTURER FROM ANY LIABILITY IN CASE OF DAMAGE ATTRIBUTABLE TO SUCH ALTERATIONS. TAMPERING OR REMOVAL OF SAFETY DEVICES IS A BREACH OF THE UK/EUROPEAN RULES RELATING TO SAFETY AT WORK.

### 3.1 Safety devices

The machine is equipped with the following safety devices:

- Wheel guard support.
- Wheel guard.
- Micro switch actuated by wheel guard support.

It is forbidden to tamper with, bypass or remove the safety devices installed because this is a

violation for the directives on safety and health at work.



THE REMOVAL OR TAMPERING WITH A SAFETY DEVICE IS A VIOLATION OF THE SECURITY EUROPEAN DIRECTIVES.

#### 4 Transport & Handling

The wheel balancer is packed in a carton box on a pallet.

Transport and handling must be carried out ONLY BY AUTHORIZED PERSONNEL, with pallet truck or forklift and adopting the appropriate safety measures.

	<b>Net weight (Kg)</b>	<b>Gross weight (kg)</b>	<b>Length (mm)</b>	<b>Width (mm)</b>	<b>Height (mm)</b>
<b>FDR1060</b>	<b>138</b>	<b>152</b>	<b>960</b>	<b>690</b>	<b>1228</b>

If the machine is not packed, observe following precautions:



PROTECT THE SHARP EDGES AT THE ENDS WITH SUITABLE MATERIAL (Bubble wrap or cardboard).



DO NOT USE METAL WIRE ROPES FOR LIFTING BOARD.



SLING WITH STRAPS OF AT LEAST 200 cm IN LENGTH AND WITH A HIGHER FLOW RATE OF 3000 kg.



DO NOT FORCE ON SHAFT AND/OR FLANGE (See pictures F4.1 and F4.2).



Picture F4.1



Picture F4.2



ALWAYS UNPLUG THE POWER SUPPLY CABLE FROM THE SOCKET BEFORE MOVING THE MACHINE.

The environmental conditions of work must be conform to the following requirements:

- Temperature from 0° C to + 45° C
- Relative humidity from 20% to 95%



## 5 Unpacking

After removing packing, check integrity of machine making sure there are no damaged parts.

In case of doubt DO NOT USE THE MACHINE and consult qualified personnel (dealer or manufacturer). The packaging materials (plastic bags, nails, screws pieces of wood, etc.) must not be left within reach of children as they are potential sources of danger. Packaging materials should be stored in the appropriate collection points if non-biodegradable pollutants.



CHECK THE PRESENCE OF THE BOX CONTAINING THE ACCESSORIES TO AVOID THROWING IT WITH PACKING.

## 6 Installation & Switching on

After unpacking wheel balancer, check the status of integrity and presence of faults, make the assembly of the components as shown in following pictures.

### 6.1 Installing display

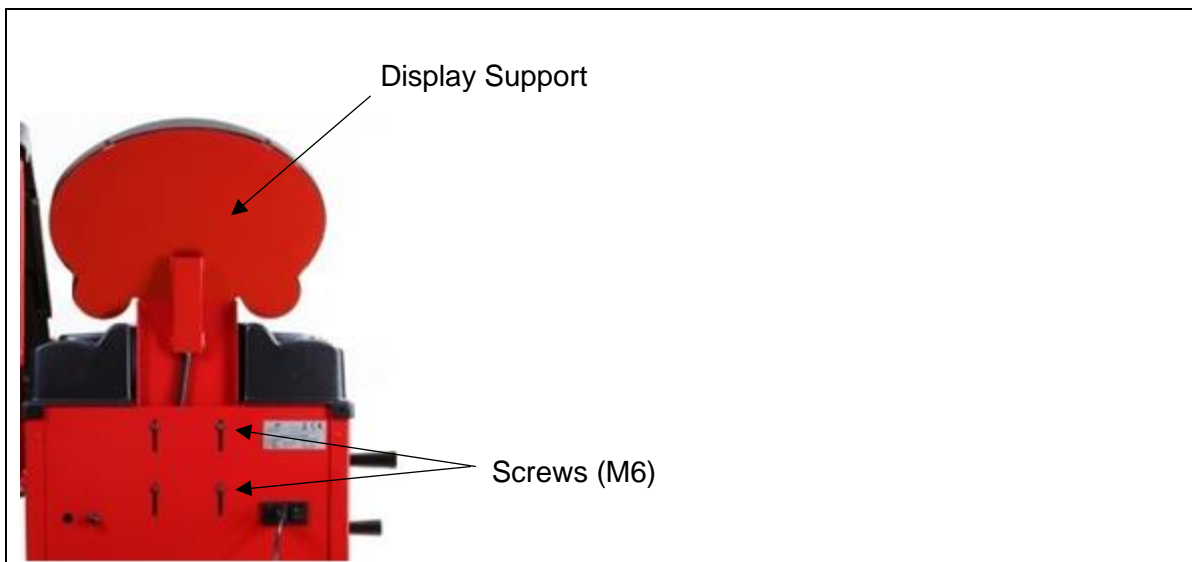

Picture F6.1

Unscrew nr. 4 M6 screws showed in pictures F6.1

Insert and position display support

Fix nr. 4 M6 screws

## 6.2 Installing wheel guard and wheel guard support

The wheel guard and its support must be installed as shown in following pictures.



Picture F6.3 and Picture F6.4: Place the tube inside the relative pin and secure it with 2 M8 bolts.



Picture F6.5 and Picture F6.6: Remove the wheel guard from the packaging and place it on the tube.



Picture F6.7: Secure the wheel guard to the tube using the relative ties.

### 6.3 Installing SONAR device (if present)

The SONAR device must be installed as shown in following pictures.

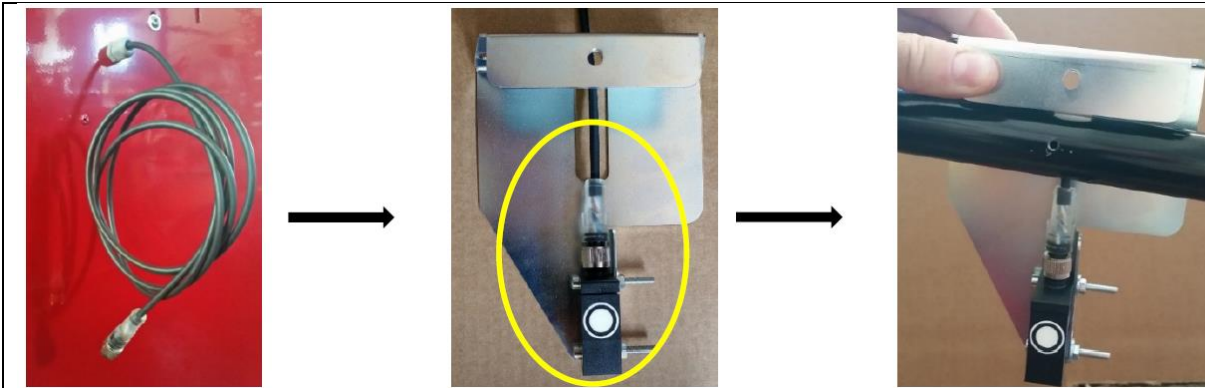

Picture F6.8 - Picture F6.9 - Picture F6.10: Connect the cable to SONAR device. Mount the device on the pipe following the holes as available on it.

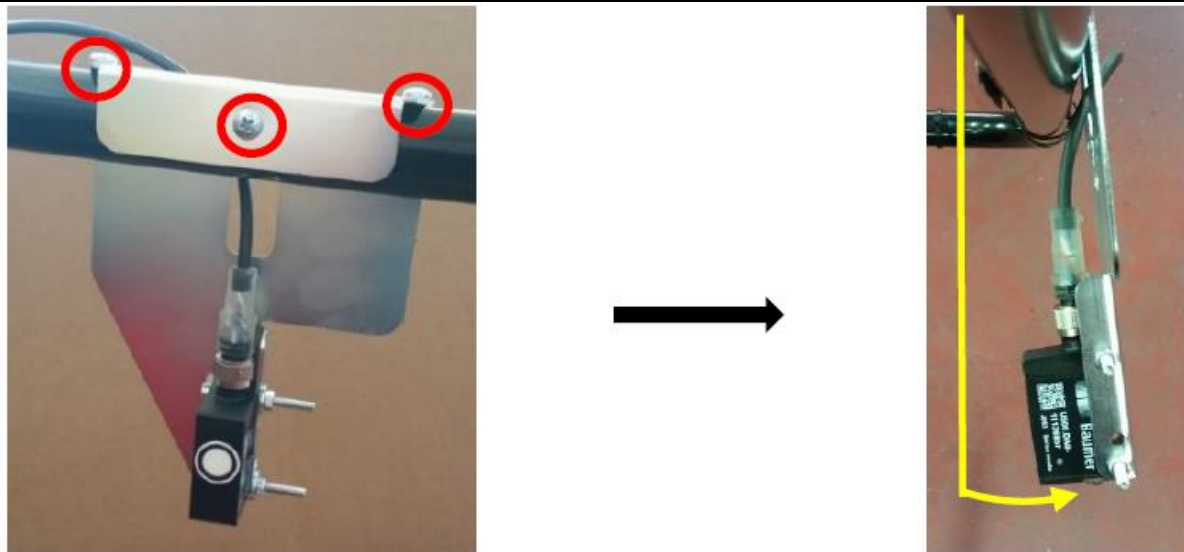

Picture F6.11 - Picture F6.12: Fix the SONAR device to the pipe. The support plate of the SONAR device must stay inclined.  
DO NOT MOVE THE INCLINED POSITION OF THE SUPPORT.

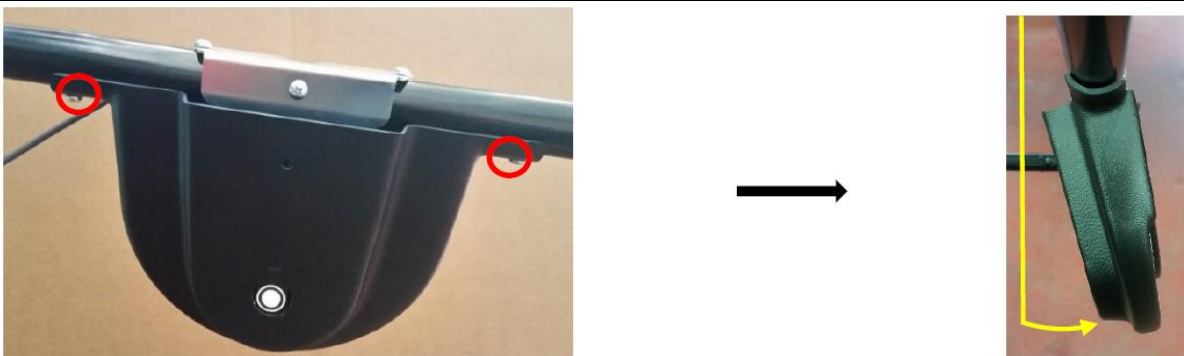

Picture F6.13: Fix the plastic cover using the relevant screws.



Picture F6.14



Picture F6.15: Once the device is mounted on the pipe, fit the plastic carter as described in 6.2.

#### 6.4 Installing external sensor (if present)

When present, the external sensor must be installed according to the pictures provided below.



Picture F6.16: Remove external sensor from the packaging.

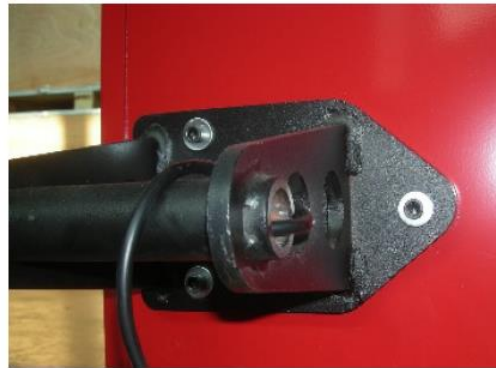

Picture F6.17 and Picture F6.18: There are holes at the back of the wheel balancer to attach the external sensor. Place the flange of external sensor on the three holes.



Picture F6.19: Square the external sensor using a level. Tighten the 3 M6 screws.



PictureF6.20: Connect the cable of the external sensor to the machine and screw on the connector.

## 6.5 Electrical connection

The standard version of the machine must be connected to a mains 230V Single Phase. It is not possible to change the power supply. To accomplish the electric connection, connect the machine's power supply cable with the plug in use in the country.



ALL OPERATIONS TO MAKE ELECTRICAL CONNECTION AND INTERVENTIONS (HOWEVER LIGHT) ON ELECTRICAL PARTS MUST BE CARRIED OUT BY QUALIFIED PERSONNEL.

The dimensioning of electrical connection must be carried out in according to electric power absorbed by the machine. The absorption is specified in paragraph 10. The user must:

- check that the supply voltage corresponds to the voltage indicated on the nameplate of the machine.
- check the conditions of the wire and the presence of the ground conductor.
- check the machine is connected to its own electrical connection, fitted with a proper 30 mA sensitive automatic circuit breaker, against a possible electrical overload over 30 mA.
- connect the power supply cable to the plug with great care and following to the current regulations.



WHEN THE MACHINE IS TURNED OFF FOR A LONG TIME IT IS NECESSARY TO DISCONNECT THE POWER PLUG TO AVOID USE BY UNAUTHORIZED PERSONNEL.



IF THE MACHINE IS CONNECTED DIRECTLY TO THE POWER SUPPLY BY MEANS OF THE MAIN ELECTRICAL BOARD AND WITHOUT THE USE OF A PLUG, INSTALL A KEY-OPERATED SWITCH TO RESCTRICT THE MACHINE USE EXCLUSIVELY TO QUALIFIED PERSONNEL.



IN CASE OF OPERATIONS ON ELECTRIC PARTS, CABLES ENGINES OR ANY ELECTRIC DEVICES, IT IS NECESSARY TO CUT OFF THE ELECTRICITY.



DO NOT REMOVE, DAMAGE AND MAKE ILLEGIBLE THE STICKERS OF DANGER, WARNING, INSTRUCTIONS AND CAUTION. REPLACE ANY MISSING, DAMAGED OR ILLEGIBLE STICKERS. THE STICKERS CAN BE FOUND AT THE NEAREST DEALER OF MANUFACTURER.



THE DAMAGE FOR FAILURE TO COMPLY WITH THE ABOVE WRITTEN INSTRUCTIONS, IT WOULD BE NOT CHARGED AGAINST THE MANUFACTURER AND IT MAY CAUSE THE INVALIDATION OF THE WARRANTY.

## 7 Installation

### 7.1 Installation Area

To install the machine you need a useful space on the basis of the information given in picture F7.1.

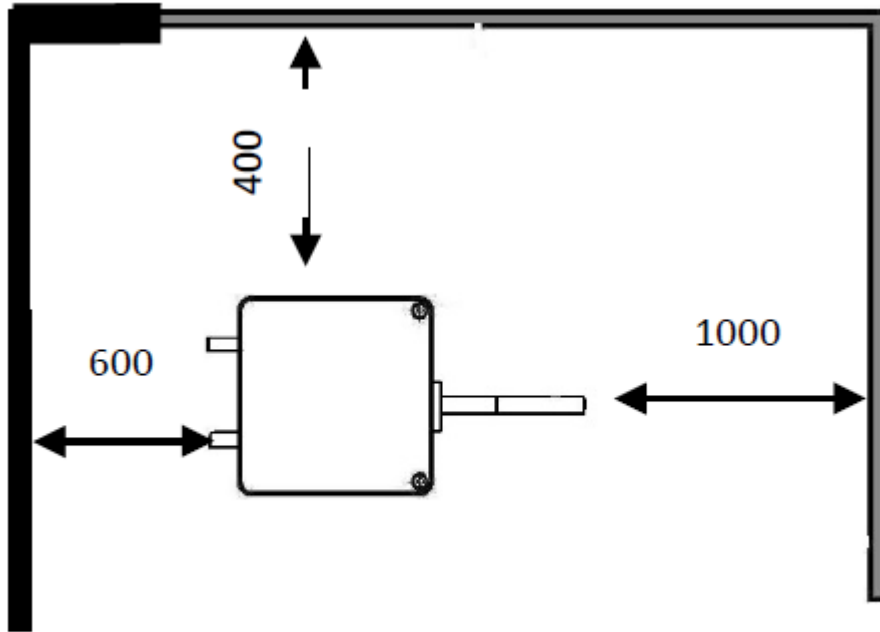

**Picture F7.1**

From working position, the user must be able to view the machine and the surrounding area.



INSTALLATION AREA MUST BE KEEP CLEAR BY POSSIBLE DANGEROUS OBJECTS.



UNAUTHORIZED PERSONNEL MUST NOT STAND NEAR BY THE WORKING AND INSTALLATION AREAS.



THE MACHINE MUST BE PLACED ON A HORIZONTAL SURFACE MADE OF CONCRETE OR TILED.



AVOID BREAKABLE AND ROUGH SURFACES. SURFACE MUST ENDURE THE STRESS LOAD DURING THE MACHINE OPERATION.



THE MACHINE MUST BE FIXED ON THE FLOOR WITH SCREWS AND EXPANSION PLUGS IN ACCORDING TO FOLLOWING INSTRUCTIONS.



THE USE OF THE MACHINE IS ONLY ALLOWED IN PLACES THAT DO NOT PRESENT RISKS OF EXPLOSION OR FIRE.



## 7.2 Fixing the machine to the ground



### GROUND FIXINGS ARE MANDATORY

1. Drill with manual drill to a depth of 35 mm.
2. Clean the hole.
3. Push the expansion plugs into the holes with small hammer blows.
4. Tight the nuts with torque wrench calibrated on 23 Nm (if you are not able to achieve this value the reason could be the hole is too wide or the concrete is not solid enough).



Picture F7.2

## 8 Suspension of Use

In case the machine is not used for a long time it is necessary to disconnect the power supply and protect all parts that could be damaged by dust.

Grease all parts that could be damaged in case of oxidation. In this specific case, protect the shaft and flange.

## 9 Environmental Information



THE DISPOSAL PROCEDURE DESCRIBED BELOW ONLY APPLIES TO MACHINES WITH THE SYMBOL OF THE WASTE BIN WITH A BAR ACROSS IT ON THEIR DATA PLATES



The crossed-out bin symbol, placed on the product and on this page, reminds the user that the product must be disposed of properly at the end of its life. This product may contain substances that can be hazardous to the environment and to human health if it is not disposed of properly. We are therefore providing you with the information below in order to prevent these substances from being released into the environment and to improve the use of natural resources.

Electrical and electronic equipment must never be disposed of in the usual municipal waste but must be separately collected for their proper treatment.

Thus, the hazardous consequences that non-specific treatments of the substances contained in these products, or improper use of parts of them, may have on the environment or on human health are prevented. Furthermore, this helps to recover, recycle and reuse many of the materials contained in these products. Electrical and electronic manufacturers and distributors set up proper collection and treatment systems for these products for this purpose. At the end of the

product's working life contact your supplier for information about disposal procedures. When you purchase this product, your supplier will also inform you that you may return another worn-out appliance to him free of charge, provided it is of the same type and has provided the same functions as the product just purchased.

Any disposal of the product performed in a different way from that described above will be liable to the penalties provided for by the nation regulations in force in the country where the product is disposed of.

Further measures for environmental protection are recommended: recycling of any packaging of the product and proper disposal for used batteries (only if contained in the product).

Your help is critical to reduce the amount of natural resources used for manufacturing electrical and electronic equipment, minimize the use of landfills for product disposal and improve the quality of life, preventing potentially hazardous substances from being released in the environment.

## 10 Technical Data

### General features

Power supply voltage	1Ph 230 V 50/60 Hz
Power consumption	100 W
Balancing speed	140 RPM
Maximum unbalance calculated	999 g.
Accuracy	X1 (1 g. or 0.1 ounce) X5 (5 g. or 0.25 ounces)
Shaft diameter	40 mm.
Working environment temperature	from 0 to +45 °C
Storage temperature	from -10 to +60 °C
Storage relative humidity	20% ÷ 95%
Machine weight (without accessories)	126 kg
Noise level	< 70 dB(A)

### 10.1 Machine dimensions

Depth with closed wheel guard	mm. 1030
Depth with open wheel guard	mm. 950
Width with wheel guard	mm. 660
Height with closed wheel guard	mm. 1228
Height with open wheel guard	mm. 1450

### 10.2 Working range

#### Wheel size set manually

	mm.	inches
Wheel - machine distance	2 ÷ 460	
Wheel width	50 ÷ 500	2.0 ÷ 20.0
Wheel diameter	25 ÷ 890	1.0 ÷ 35.0

Wheel size set automatically

	mm.	inches
Wheel width	Max. 490	Max. 19.5
Wheel diameter	235 ÷ 710	9.5 ÷ 28.0

Wheel features

Max. wheel diameter (with guard)	1120 mm.
Max. wheel width (with guard)	590 mm.
Max. wheel weight	75 kg.

Table T10.1: Functions for machine models

Function	FDR1060
Distance and diameter automatic acquisition	
Width automatic acquisition	optional
Balancing accuracy	± 0,5 g.
FMB Parking brake pedal	optional
Distance sensor designed for sticking adhesive weights	
CFC Car wheels calibration with zero-settings of the unbalance in the flange	
MFC Motorbike wheels calibration with zero-settings of the unbalance in the flange	
Static/Dynamic balancing	
OPT Optimization program	
Grams/ounces selection	
Inches/mm selection	
AAP - AUTOMATIC ALUMINUM PROGRAM	
Car wheels programs (CAR) STD, ALU1, ALS1, ALS2	
Off-road wheels programs (SUV) STD, ALU1, ALS1, ALS2	
Motorbike wheels programs MOTO ALU1	
STATIC program	
DYNAMIC program	
HYDDEN WEIGHTS program	
STAND BY function	
MSO Multi operators management	
GSW Iron/Zinc/Lead counterweights selection	
LWH Led lighting	optional
LASER	optional
USB port for software update	optional
Service programs	

= Present/Available

### 10.3 Presentation of the machine

1. Distance/Diameter sensor
2. Display/Keyboard panel
3. Main switch
4. Weight-ray
5. Wheel guard with support
6. Shaft
7. Pin for cones
8. Brake pedal (if present)



### 11 Identification Data

A complete description of the “Wheel Balancer Model” and the “Serial number” will make it easier for our technical assistance to provide service and will facilitate delivery of any required spare parts. This information can be found on the product serial plate.

### 12 Maintenance

To ensure the efficiency of machine and its proper functioning is essential to follow the manufacturer’s instructions by performing periodic cleaning and routine maintenance.



CLEANING AND ORDINARY MAINTENANCE MUST BE PERFORMED BY THE AUTHORIZED PERSONNEL IN ACCORDANCE WITH THE MANUFACTURER INSTRUCTIONS PROVIDED BELOW.

Always keep the flanges clean and tidy (non-lubricated). In addition, during the handling, pay the best attention to not damage. For cleaning the machine, especially for the weight-ray, use a soft cloth moisten with ethyl alcohol.



EVERY OPERATION MUST BE DONE ONLY AFTER THE CABLE HAS BEEN DISCONNECTED FROM ITS POWER SUPPLY.



DO NOT BLOW COMPRESSED AIR TO CLEAN THE MACHINE AND LASER POINTER.  
DO NOT USE WATER OR OTHER LIQUIDS FOR CLEANING THE MACHINE.

### 13 Control Panel

The machine control panel is shown in picture F13.1. The control panel allows the operator to give commands and enter or modify data. The same control panel displays the balancing results and machine messages. The functions of the various sections of the control panel are described in table T13.1. The rear side of the control panel contains the CPU-C1 electronic board that collects, processes and displays data.

Picture F13.1 Control panel

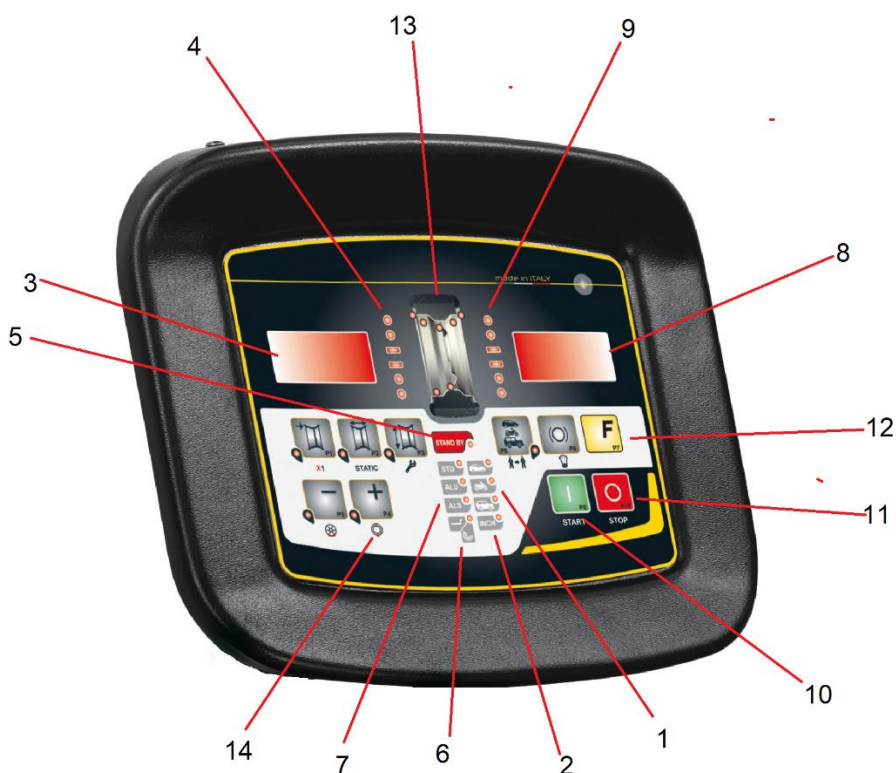



Pos.	Description
1	Wheel type light indicator CAR/MOT/SUV (meaning Car/Bike/Off Road).
2	Unit of measure light indicator: inch (red led on) - mm (red led off).
3 - 8	Display shows unbalance value inside - outside.
4 - 9	Light indicators show angular unbalance position inner - outer.
5	Stand-by light indicator.
6	Light indicator for automatic acquisition system of dimensions wheel is turned on (red led) - turned off (red led off) or flashing temporarily disable.
7	Program Type light indicator (Standard/ALU/ALU S). Group of 3 light indicators (red led on) indicate the Program Type selected.
10	Start key to start the motor (P8).
11	Stop key to stop the motor (P10).
12	F key to access the secondary function of the keys (P7).
13	Imbalance Position light indicator. Group of 7 lights indicators (red led on). Position depends by the Program and Wheel Type selected.
14	Standard key sample: it has a main function (big symbol shown inside the key) and secondary function (small symbol shown beside the key).

### 13.1 Keyboard

In this manual, the keys are numbered for convenience from [P1] to [P10] as shown in picture F13.1. Beside the key reference numbers the key symbols (for an easy-to-read) are shown.

The ten buttons have a main function indicated by a symbol in the big circle and a secondary function indicated by the symbol in the small circle located along side. Some of the secondary functions feature a led to indicate their activation. The keys

[P7] , [P8] Start  and [P10] Stop  do not have a secondary functions. The secondary function of the keys is identified in this manual with the codes from [F+P1] to [F+P9] as shown in picture F13.3.

Picture F13.2: Key sample showing the main and secondary function



To enter the secondary function of the keys press the key [P7]  then, by holding down, press one of the keys for these secondary function you want, then release both keys.

Picture F13.3: Numbering of the secondary function of the keys

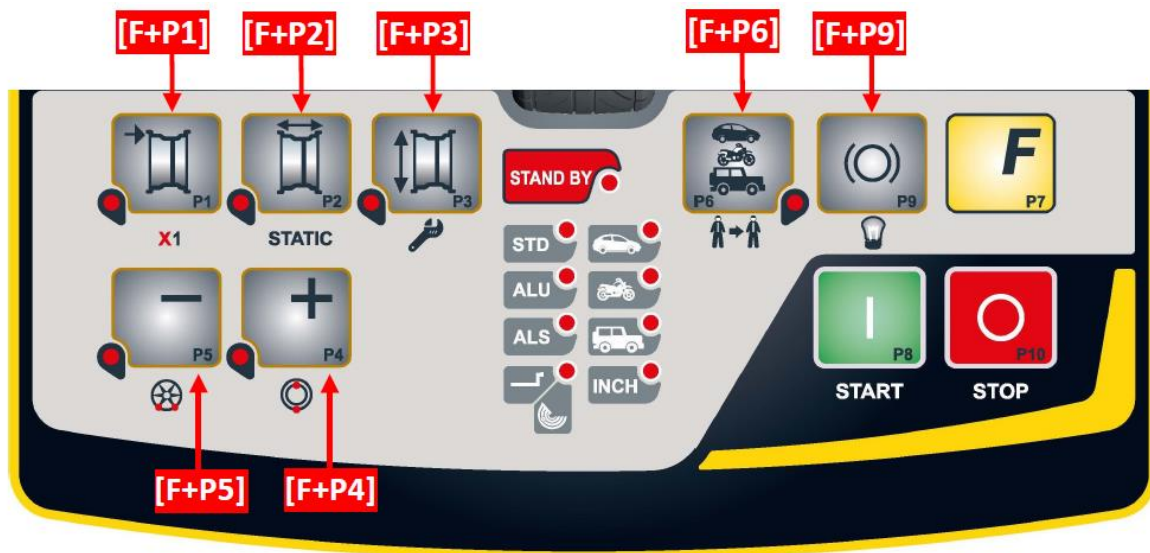

Table T13.2: Settings, programs and menu available in the SERVICE mode

Service Mode			
Key	Setting/Program or menu	Key	Setting/Program or menu
P1	Sensors calibration programs	F+P1	Not used
P2	Not used	F+P2	Select weight material in Fe/Zn or Pb
P3	Machine calibration	F+P3	Exit SERVICE mode (return to NORMAL mode)
P4	Grams/ounces selection	F+P4	Read counter with the number of spins
P5	Inches/mm selection	F+P5	Parameters MENU (Menu with password reserved for technical service)
P6	Select the imbalance threshold view	F+P6	Not used

Note: the keys [P7] [P8] Start and [P10] Stop are not used to access settings, programs or Menus.

The keys [P8] Start and [P10] Stop have a different effects depending on the position of the wheel guard as indicated in table T13.3.

Table T13.3: Effect of the Start and Stop keys in relation to the state of the wheel guard

Pressed key	Wheel guard position	Result
[P8] Start 	OPEN/HIGH	<ul style="list-style-type: none"> <li>If the stopping brake is disabled the machine doesn't spin and emit three beeps to alert the required function cannot be taken;</li> <li>If the stopping brake is enabled and the machine shows imbalance positions the machine performs a low speed spin (SWI procedure. See paragraph for <i>SWI stop the wheel on imbalance</i>).</li> </ul> NOTE: for security and safety for the operator, the SWI procedure is not performed when it is enabled the MOTO Wheel Type.
	CLOSED/LOW	The machine will run the balancing or testing spin.
[P10] Stop 	OPEN/HIGH	No action.
	CLOSED/LOW	<ul style="list-style-type: none"> <li>No action if the wheel is spinning;</li> <li>Spinning stop if this is in progress.</li> </ul>

### 13.2 Operating modes STANDARD, SERVICE, STAND-BY

The machine features three operating modes:

- STANDARD mode. This mode is enabled after the machine is turned on and it is possible to perform the wheels balancing.
- SERVICE mode. In this mode various utility programs are available for setting parameters (such as grams or ounces) or checking the machine operations (such calibration).
- STAND-BY mode. After 5 minutes without user activity, the machine automatically switch to STAND-BY mode to reduce electrical consumption (both with wheel guard raised or lowered). The STAND-BY green led on the control panel is blinking it means the machine is in this operating mode. All acquired data and settings are held in STAND-BY mode. In the SERVICE mode is not possible to switch to STAND-BY mode.

To exit from STAND-BY mode choose by any of the following means:



Press any keys (with the exception of [P7])

- Turn manually the wheel
- Pull out the distance/diameter sensor from idle position (only for the models with automatic acquisition of distance/diameter)
- Pull out the external sensor from idle position (only for the models with automatic acquisition of width).

**Note:** the machine exits the STAND-BY mode also by pressing the key [P8]  or lowering the wheel guard. In these cases simultaneously, will be start also the spinning (if

you press [P8]  Start the spin will start only if the wheel guard is already lowered).



# 14 Switching the Machine - Diagnostic

Diagram D14.1: Program flow at machine switching on

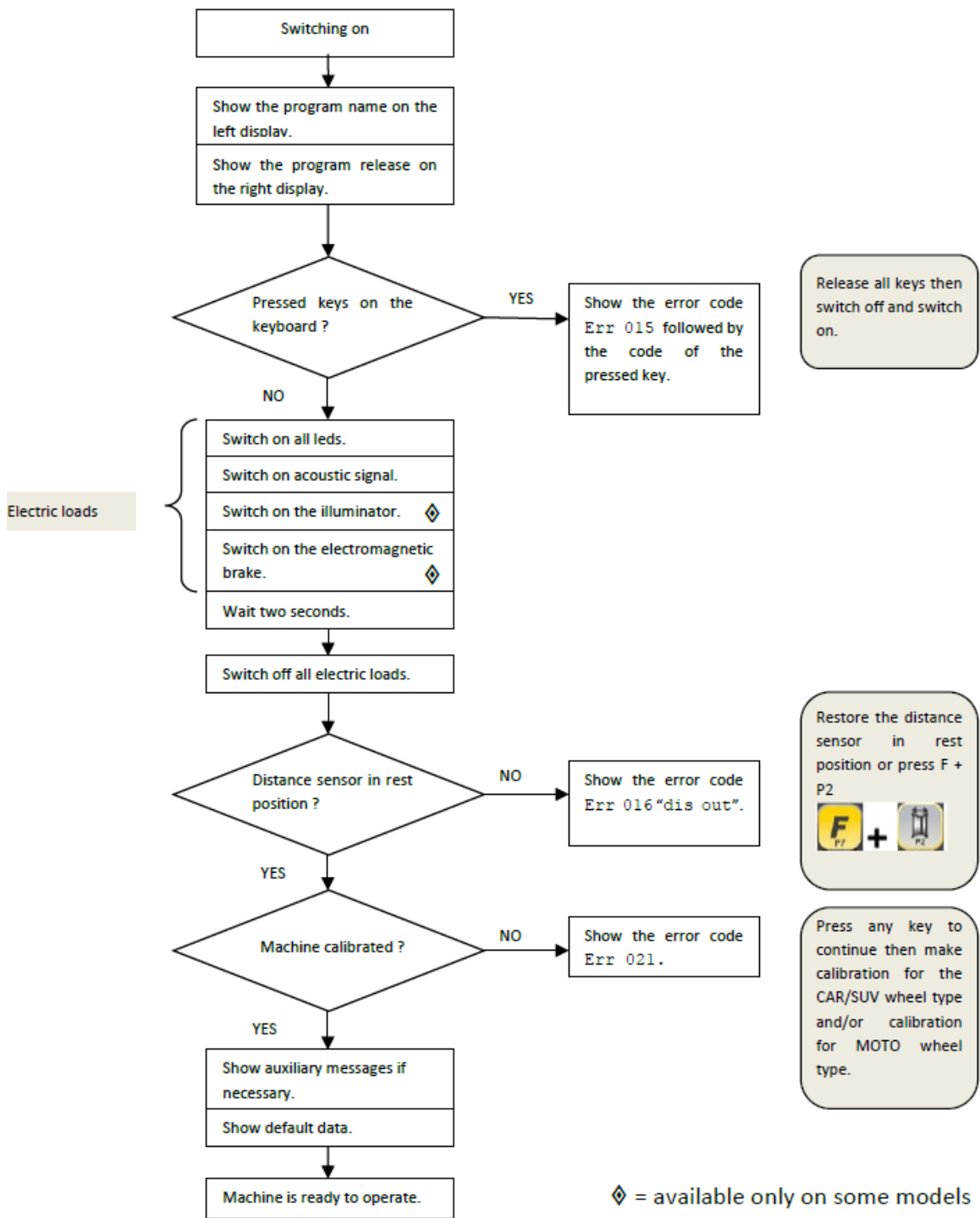

#### 14.1 Temporary disabling of the diameter and distance sensor (where applicable)

If the machine displays the error code Err 016 “dis out” (Distance/Diameter sensor not in the rest position) at switching on, although being in rest position, it means that an anomaly occurred in the acquisition system.

It is possible to temporarily disabling the Diameter/Distance sensor by pressing keys [F+P2]





The led on the Spanel will switch off [6]  indicating the automatic acquisition of Diameter/Distance is disabled and the machine is ready to be used. Since the automatic acquisition data system is disabled, wheel dimensions must be entered manually as described in chapters 15.3.1 and 15.3.2. Switching off and then switching on the machine, the error code will appear again and it is necessary to set again as described above. If the automatic acquisition system is malfunctioning and it blocks the machine in a permanent acquisition function, the temporary disabling could be done also after the machine is switched on.

**Note:** the temporary disabling of the Diameter/Distance sensor also operates on the sensor for the automatic acquisition of width (if present).

#### 14.2 Temporary disabling of the width sensor (where applicable)

If the machine displays error code Err 017 “Lar out” (Width sensor not in the rest position) when powered up, even if in rest position, it means that an anomaly occurred in the acquisition system.

It is possible to temporarily disabling the width sensor by

pressing keys [F+P2]  led on the panel will switch off [6]  indicating the automatic acquisition of width is disabled and the machine is ready to be used. Since the width sensor is disabled, width dimension must be entered manually, as described in chapters 15.3.1 and 15.3.2. Turning off and then switching on the machine, the error code will appear again and you must set again as described above. If the width sensor is malfunctioning and it blocks the machine in a permanent acquisition function, the temporary disabling could be done also after the machine is switched on.

**Note:** the temporary disabling of the width sensor also acts on the sensor for the automatic acquisition of Distance/Diameter sensor (if installed).

### 15 Use of the Machine in Normal Mode Display/keyboard panel on the machine

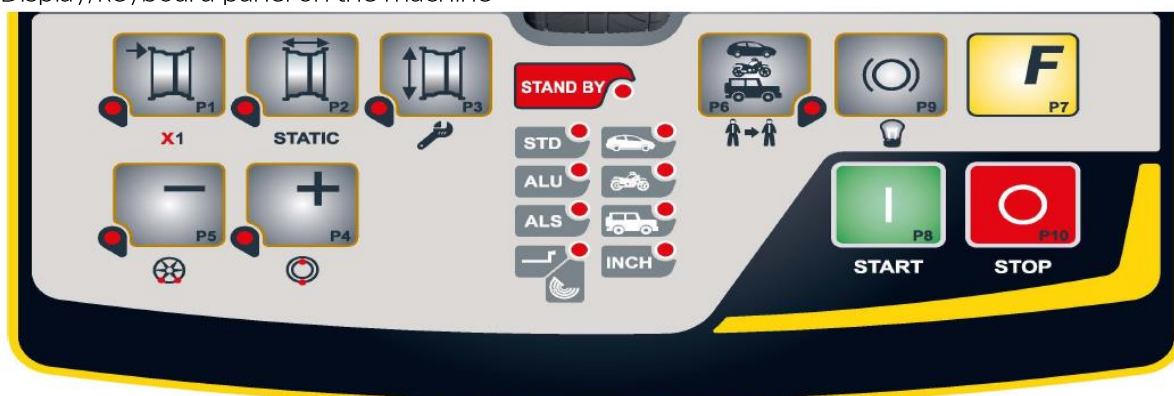

To use the machine, you must select or set as follows:

- Program Type (program for wheels with steel, aluminum or special aluminum rim). Default = program for wheels with steel rims;
- Wheel type (auto-vehicle, motorbike, off-road). Default = auto-vehicle;

- Dimensions of the wheel to balance. The dimensions can be manually entered (always) or partially or fully in automatic (available only on some models);
- Dynamic or Static balancing. Default = Dynamic;
- Display resolution X1 or X5. Default = X5.

The selections described above can be entered before or after the spin. For any variation of the selection or data settings, the machine will run a calculation by displaying the new values of imbalance.

Once the selections/settings have been entered, you can run a spin by pressing the key [P8]

Start  or lowering the wheel guard. At the end of the spin, the machine displays the wheel imbalance values.

Apply the weights displayed by the machine at the indicated positions and then run a second test spin. Normally, the weights should be applied at the 12 o'clock with the exception of special programs for ALS1 and ALS2 aluminium.



### 15.1 Type of program (Program Type)

The machine allows the choice between eight different Program Types of balancing as listed in table T15.1.

Table T15.1: Program Types available

Program Type	Wheel material	Weight position along the rim selection	Automatic acquisition <sup>(1)</sup>	Notes
STD	Steel	Default	2 sensors or SONAR	Default at power on
ALU1	Aluminum	Default	2 sensors or SONAR	Forcibly set when the Motorbike Program Type is selected
ALS1	Aluminum	Default inner weight, outer weight provided by user	1 sensor	
ALS2	Aluminum	Provided by user	1 sensor	

(1) Available on some models

Programs can be selected in STANDARD mode by pressing key [P4]  or [P5]  the first press of one of the two keys, on the display the current program in use is shown, if, within a lapse of 1.5 seconds, none of the two keys are pressed again, the view returns to its previous state without changing the type of program activated.

The leds of the display panel are lighten on the basis of the Program Type activated:

- Program Type led. See picture F13.1 detail [7].
- Led Imbalance Position Weights. See picture F13.1 detail [13].

**Note:** the selection of the Program Type STD removes the visualization of Static Imbalance.

The selected Program Type also influences the automatic acquisition of wheel dimensions (feature available only on some models of machine) as indicated in Automatic acquisition column in table T15.1. The acquisition that features only one sensor uses the Distance/Diameter sensor. The position of the balancing weights along the section of the rim in the various Program Types is shown in picture F15.1.

Picture F15.1: Position of the weights in the various Program Types along the section of the rim.

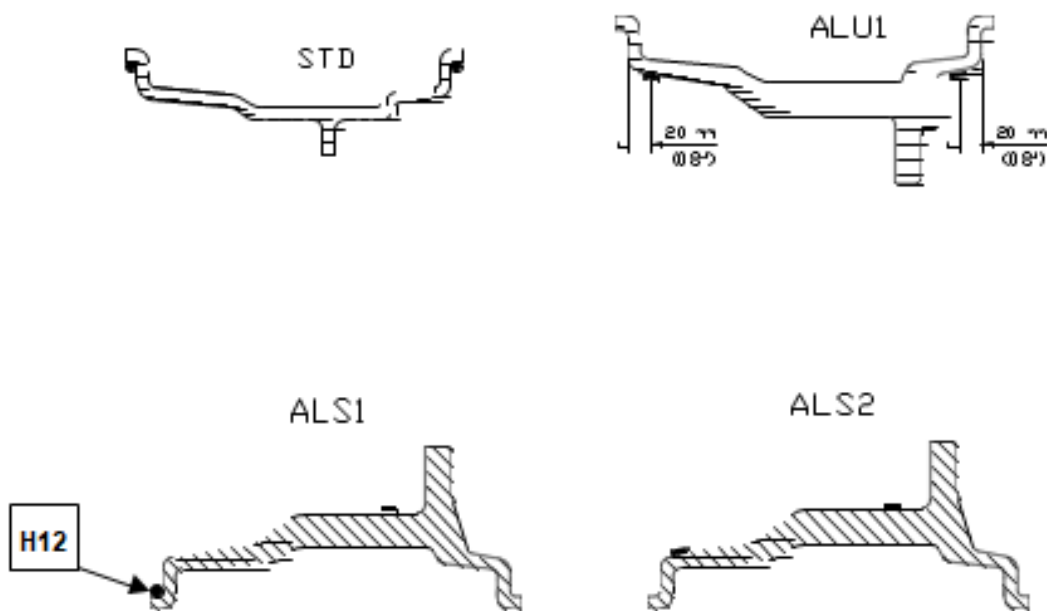

Angular position of the balancing weights in the several Program Type is shown in table T15.2.

Table T15.2: Angular position of the balancing weights in the various Program Types

Machine data acquisition system	Program type								
	STD, ALU1			ALS1			ALS2		
	Internal plane	External plane	Static plane	Internal plane	External plane	Static plane	Internal plane	External plane	Static plane
Semi-automatic FDR1060	H12	H12	H12	H12	Sensor-rim contact point(1)	H6	Sensor-rim contact point(1)	Sensor-rim contact point(1)	H6

Note (1): if the data acquisition system is disabled, the angular position of the weight will be in the 6 o'clock position.

In table T15.2 the symbol "H12" indicates that the angular position of the weight is at 12 o'clock while the symbol "H6" indicates that the angular position of the weight is at 6 o'clock.

The machine data acquisition systems are defined as follows:



- Manual when the data of the rim must be all manually entered
- Semi-automatic when the Distance and Diameter data are automatically acquired with the Distance/Diameter sensor while the data on the width must be manually entered;
- Automatic when all data of the rim is automatically acquired with the two sensors.

Automatic or Semi-automatic machines with disabled sensors (due to malfunctions or other reasons) become fully manual machines. The data rim must be entered manually and the angular position of the weight follows the rules of the manual machines.

## 15.2 Wheel Types

The machine allows choosing between three different Wheel Types as listed in table T15.3.

Table T15.3: Wheel Types to select

Wheel Type	Vehicle	Notes
CAR 	Auto-vehicles	Default power on
MOTO 	Motorbikes	Forcibly set the ALU1 Program Type
SUV 	Off-Road vehicles	Not suitable for balancing truck wheels

Each of the above programs set up specific values to measure the wheel dimensions and to calculate the imbalances. The special features of each program are listed in the following paragraphs.

To select a specific Wheel Type, press repeatedly [P6]



key until the corresponding LED

### 15.2.1 CAR wheel type (auto-vehicles)

The selection of the CAR Wheel Type allows the balancing of wheels of auto-vehicles. For OFF-ROAD vehicles, it may be appropriate to select the SUV Wheel Type (see paragraph below).

To select CAR wheel type, press repeatedly [P6]



key until the CAR LED of the



Wheel Type group LED lights up. See table T15.3.

### 15.2.2 MOTO wheel type (motorbikes)



The selection of MOTO wheel type allows the balancing for the motorbike wheels. These wheels must be fitted on the shaft by using a specific (optional) motorcycle wheel adaptor. Since the motorcycle adaptor keeps farther the wheel from the machine, it is necessary to install an appropriate extension for the diameter gauge (picture F15.1.1).

To select the MOTO wheel type, press key [P6]  repeatedly until the Wheel Type light indicator for MOTO is lighted on. See table T15.3.

When the Wheel Type MOTO is activated, automatically, the ALU1 Program Type is selected, if you

attempt to select another programs by keys [P4]  or [P5]  the machine will display the error code ERR 043. The application point of the weights along the rim section is that of ALU1 Program Type as shown in picture F15.1.

When the Wheel Type MOTO is activated, it is possible to display the dynamic or static imbalance,

by pressing keys [F+P2]  +  the wheel width entered is less than 114 mm (or 4.5 inches) the static imbalance is always displayed.

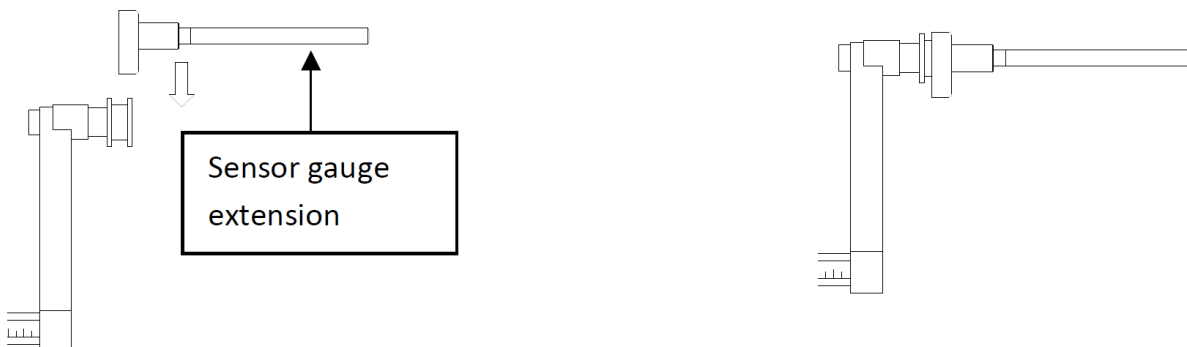

To acquire automatically the geometrical wheel data by Distance/Diameter and Width sensors, it is necessary to keep the same reference points on the rim as Program Type ALU1. Furthermore, when the Wheel Type MOTO is selected, the actual distance value is increased of 150 mm due to the extension length for the Diameter/Distance sensor.

Picture F15.1.1: Fitting the extension for Distance/Diameter sensor to measure motorbike wheels



**NOTE:** for the machines which are not equipped with the Distance/Diameter sensor (or for the machine where Distance/Diameter sensor is disabled) the distance value must be entered manually. To carry out this operation the following operations should be executed:

- lean on the rim the extension point of the Diameter/Distance sensor,
- Read the distance value on the rule,
- add to the value read 150 mm,

d) enter manually the distance value by pressing key [P1]  and then keys [P4]  or [P5] 

Each time the motorcycle adaptor is removed (for example for balancing a car wheel) and installed again, it is always necessary to match the written "Cal" which are present on the flange and on the motorcycle adaptor otherwise the balancing accuracy may be compromised.

### 15.2.3 SUV wheel type (Off-Roads vehicles)

The selection of SUV wheel type allows the balancing of wheels for off-road vehicles. These vehicles are generally equipped with wheels that are larger than normal and the tyre is relatively large compared to the diameter of the rim (that means not the low profile or super low profile types). The selection for this wheel type doesn't allow to balance the truck wheels, because the profiles for those rims are considerably different.

The choice of the CAR or SUV wheel type is at the discretion of the operator who should run balancing test to determine which wheel type gives the best results for the particular wheel that is subject to balancing.

To select SUV type wheel press repeatedly [P6]  key until the Wheel Type light indicator for SUV is lighted on. See table T15.3. For SUV wheel type all Programs Type listed in table T15.1 are available. The weights position to be applied on the rim section are the same as those shown in picture F15.1.

### 15.3 Entering wheel dimensions

The dimensions of the wheel to balance can be entered in two ways:



- Manual Mode. This mode is always available.
- Automatic Mode. Only some models are equipped with sensors for the automatic entering (partial or total) of wheel dimensions.

Note: all the machines are equipped with a graduated scale for manually measuring the distance.

#### 15.3.1 Manual entering of the wheel dimensions for the STD and ALU1 Program Types



To introduce the wheel size manually, proceed as follows:

1. Fit the wheel on the shaft and tighten with the ring nut.
2. Extract the distance sensor and place it on the wheel as shown in picture F15.2.
3. Read distance value on the graduated scale as shown in picture F15.2. The distance value is always expressed in millimetres.

4. Press [P1]  key to modify the distance and then press [P4]  key or [P5]  key within 1,5 seconds to enter the read value. If you do not press buttons [P4] or [P5] within this time limit, the machine will return to the previous display. In this case, you can press



[P1]  again to enter or edit the data.

5. Measure the width of the wheel with the special gauge or read the value of the width indicated on the rim. The value of the width can be in inches or millimetres according to the selected unit of measure.

6. Press [P2]  key to modify the width and press [P4]  key or [P5]  key within 1,5 seconds to enter the read value. If either one of these two keys is not pressed within in this time limit, the machine will return to the previous display. In this case, you

can press [P2]  key again to enter or edit the data.

7. Read the value of the diameter indicated on the rim or tyre. The value of the diameter can be in inches or millimetres according to the selected unit of measure.

8. Press [P3]  key to modify the diameter value and then press [P4]  key or [P5]  key within 1,5 seconds to enter the read value. If either one of these two buttons is not pressed in this time limit, the machine will return to previous display. In this case you

can press [P3]  key again to enter or edit the data.

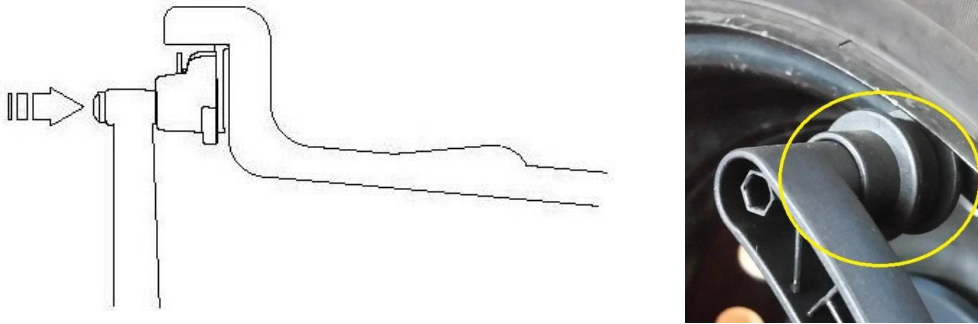

Picture F15.2: Manual acquisition of wheel dimensions: placing the distance sensor







### 15.3.2 Manual entering of the wheel dimensions for ALS1, ALS2 program types



To manually introduce the wheel size, proceed as follows:



1. Fit the wheel on the shaft
2. If the selected program type is ALS1 extract the distance sensor and place it on the wheel as shown in picture F15.3 otherwise proceed with the step 4.
3. If the selected program type is ALS2 extract the distance sensor and place it on the wheel as shown in picture F15.4.
4. Read the value of the internal distance of the plane on the graduated scale. The distance value is always expressed in millimetres.

5. Press [P1]  once to view the di1 parameter (distance of the internal surface) and press [P4]  or [P5]  within 1,5 seconds to enter the read value. If either one of these two buttons is not pressed in this time limit, the machine will return to the previous

- display. In this case you can press [P1]  again to enter or edit the data.
6. Extract the distance sensor and place it on the plane chosen for the external weight as shown in picture F15.5.
  7. Read the distance value on the graduated scale. The distance value is always expressed in millimetres.

8. Press [P1]  twice in rapid sequence until di2 (distance of the external surface) is displayed and, within 1,5 seconds, press [P4]  or [P5]  to enter the read value. If either one of these two buttons is not pressed in this time limit, the machine will return

to the previous display. In this case you can press [P1]  again twice in rapid sequence, to enter or edit the data [P1]  again twice in rapid sequence, to enter or edit the data.



9. Press [P3]  key once to view da1 (diameter of the internal surface) and within 1,5 seconds, press the keys [P4]  or [P5]  to enter the value resulting from one of the two methods described in the note below. If either one of these two buttons is



not pressed in this time limit, the machine will return to the previous display. In this case

you can press [P3]  again to enter or edit the data.

10. Press [P3]  twice in rapid sequence to view da2 (diameter of the external surface)

and keys [P4]  or [P5]  within 1,5 seconds to enter the value resulting from one of the two methods described in the note below. If either one of these two button is not pressed in this time limit, the machine will return to the previous display. In this case

you can press [P3]  again to enter or edit the data.

**NOTE:** The nominal wheel diameter doesn't match with the diameters where the weights are really applied. There are two ways to detect da1 and da2 diameters to be entered in the procedures at paragraphs 9) and 10).

#### MANUAL ENTERING DIAMETERS da1 AND da2

With this method it is possible to manually enter da1 e da2 diameters, or just da2 outer diameter (depending on the Program Type selected) by means of a measuring tap. The values to enter are shown in table T15.4.

Table T15.4: Measuring the da1 and da2 diameters for manual entering of the data

Program Type	Internal diameter da1	External diameter da2
ALS1	Enter the nominal diameter of the rim.	<i>Enter the actual diameter <b>da2</b> measured with the aid of a measuring tape. The measurement must be performed on the balancing plane chosen for <b>da2</b>.</i>
ALS2	Enter the actual diameter <b>da1</b> measured with the aid of a measuring tape. The measurement must be performed on the balancing plane chosen for <b>da1</b> .	<i>Enter the actual diameter <b>da2</b> measured with the aid of a measuring tape. The measurement must be performed on the balancing plane chosen for <b>da2</b>.</i>

ENTERING da1 AND da2 STARTING FROM THE NOMINAL DIAMETER

This method is used with the nominal diameter of the rim with the corrections indicated in table T15.5.

Table T15.5: Determining diameters da1 and da2 starting from the nominal diameter.

Program Type	Internal Diameter da1	External Diameter da2
ALS1	da1 = nominal rim diameter.	da1 = nominal rim diameter. da2 = nominal diameter - 2.0 inches.
ALS2	da1 = nominal diameter - 1.0 inch.	da1 = nominal rim diameter. da2 = nominal diameter - 2.0 inches.

Since manual measuring is not required, this method is faster but the results may be slightly less accurate.

Picture F15.3: Manual acquisition of wheel distance in ALS1 Program Type

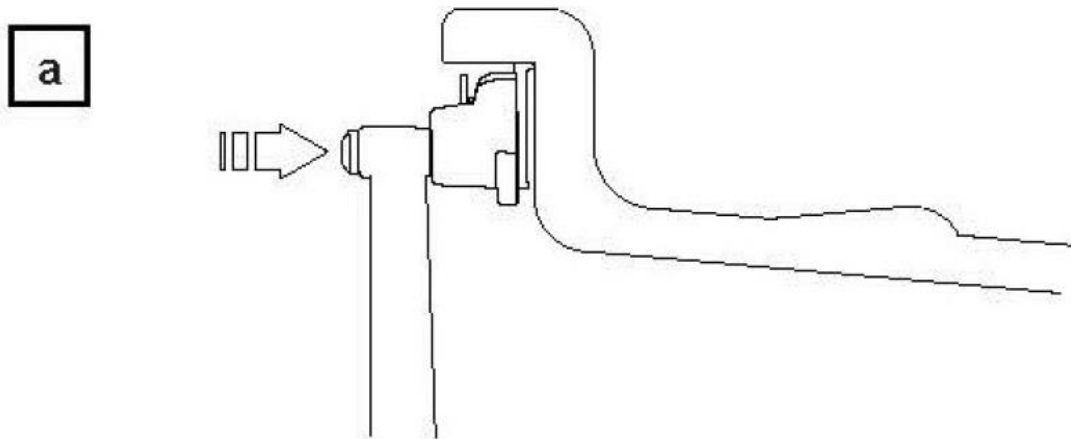

Picture F15.4: Manual acquisition of the internal plane distance in ALS2 Program Type

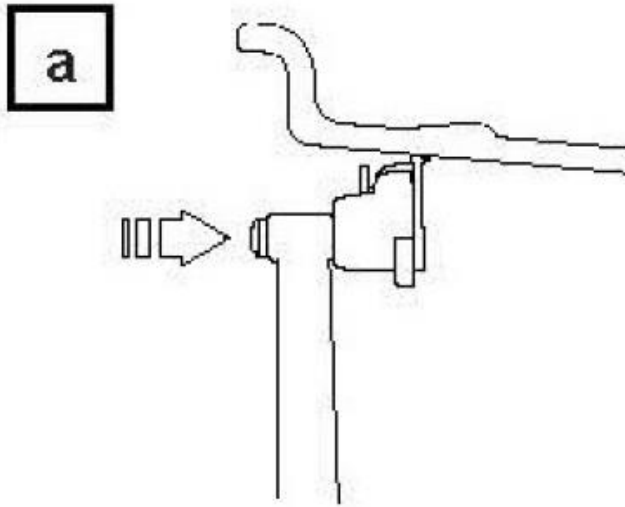



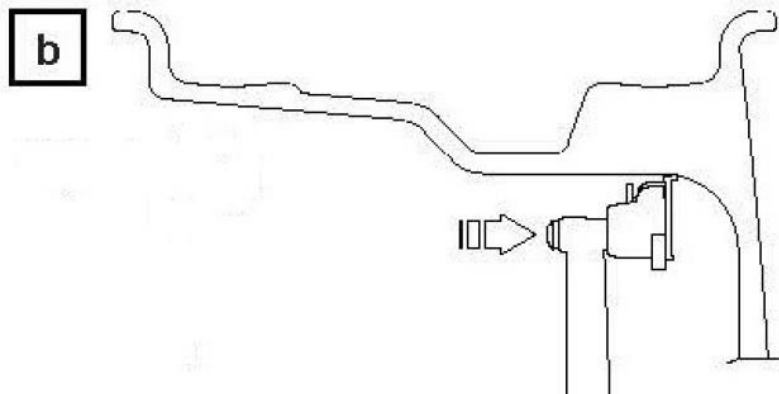

Picture F15.5: Manual acquisition of the external plane distance in ALS1 and ALS2 Program Types



### 15.3.3 Automatic acquisition of the wheel dimensions for the STD and ALU1 Program Types

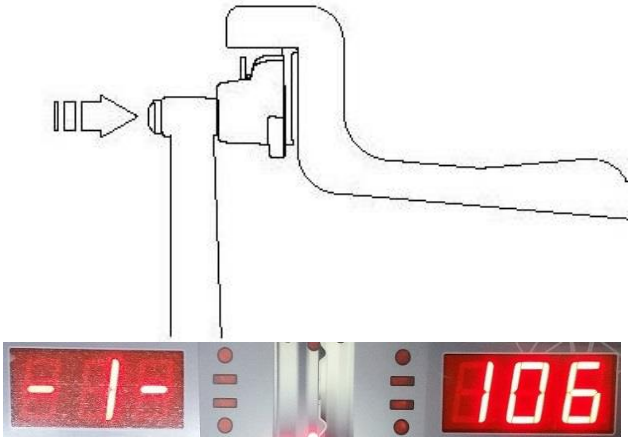



Machine without Width sensor

To automatically introduce the wheel size data, proceed as follows.

	Description	
10	Fit the wheel on the shaft and tighten with the ring nut.	
20	Extract the distance/diameter sensor and place it on the rim as shown here. When the distance/diameter sensor come back in rest position it is automatically activated the STANDARD program. 	
30	Wait to hear the long acquisition beep and then set the Distance/Diameter sensor back to the rest position. During acquisition the distance and diameter values are displayed on the display.	
40	Manually introduce the rim width. The width of the rim is normally printed on the rim itself. Alternatively use the appropriate width measuring gauge. To change the data press the [P4]  or [P5] 	

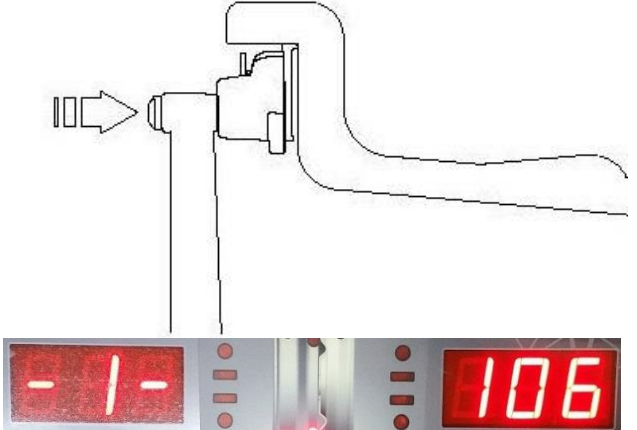
#### ALU1 Program Type selection

	Description	
10	Fit the wheel on the shaft and tighten with the ring nut.	
20	Only for programs STD, ALU1: take out first the width sensor and THEN the distance/diameter sensor and place them on the rim, as shown here. When the distance/diameter sensor come back in rest position it is automatically activated the	

	<p>STANDARD program.</p> 	
30	<p>Wait to hear the long acquisition beep and then set the sensor back to the rest position. During acquisition the distance and diameter values are displayed on the display.</p>	
40	<p>Press the keys [P4]  or [P5]  to activate the "ALU 1" program.</p>	

**Machine with width sensor (if present)**

To acquire the wheel dimensions, proceed as described below:

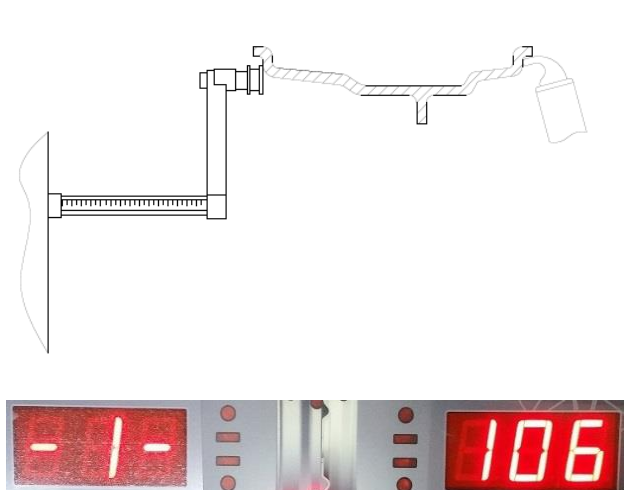
	Description	
10	Fit the wheel on the shaft and tighten with the ring nut.	
20	<p>Only for programs STD, ALU1: Take out first the width sensor and THEN the distance/diameter sensor and place them on the rim, as shown here. When the both sensors come back in rest position, it is automatically activated the STANDARD program.</p> 	

30 Wait to hear the long acquisition beep and then set the sensors back to the rest position. During acquisition the distance and diameter values are displayed on the display.



ALU1 Program Type selection

Description

10 Fit the wheel on the shaft and tighten with the ring nut.

20 Only for programs STD, ALU1: take out first the width sensor and THEN the distance/diameter sensor and place them on the rim, as shown here. When the distance/diameter sensor come back in rest position it is automatically activated the STANDARD program.

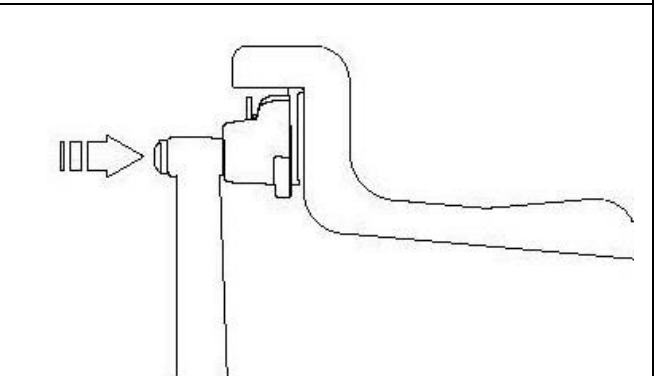

30 Wait to hear the long acquisition beep and then set the sensor back to the rest position. During acquisition the distance and diameter values are displayed on the display.





40 Press the keys  or  to activate the "ALU 1" program.





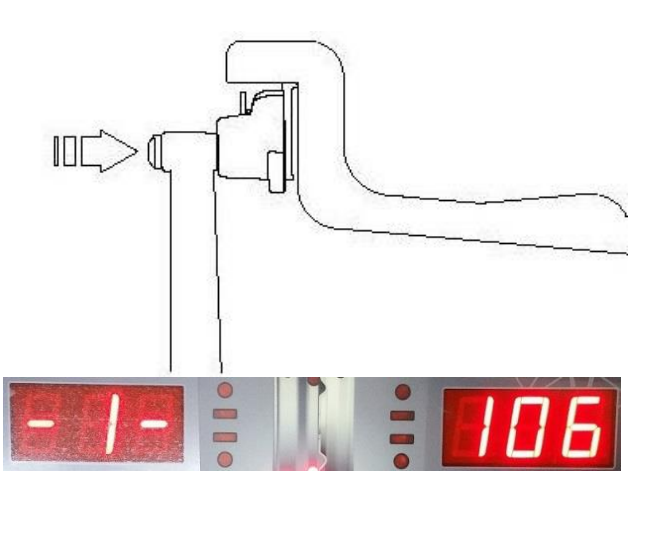

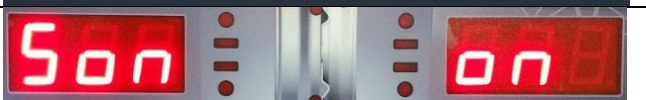

*Note: the width is not displayed during automatic acquisition. The acquired width is displayed for approximately 1,5 seconds when both of the sensors are set in the rest position.*

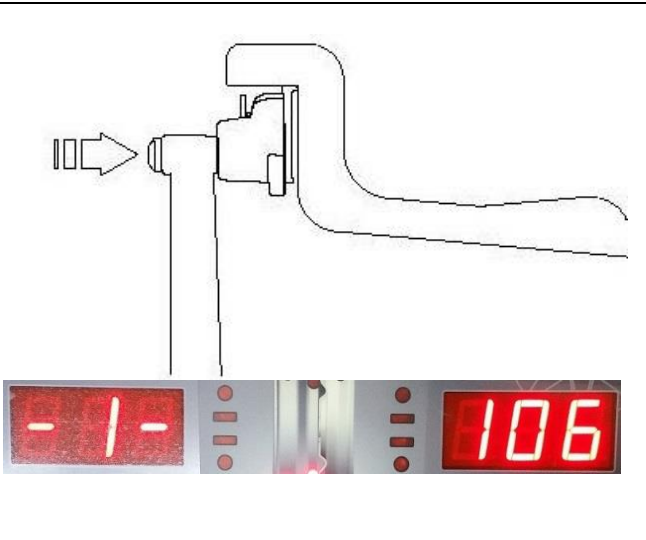
Machine with SONAR device (if present)

	Description	
10	Fit the wheel on the shaft and tighten with the ring nut.	
20	Take out the distance/diameter sensor and place it on the rim, as shown here. When the distance/diameter sensor come back in rest position, it is automatically activated the STANDARD program.	
30	Wait to hear the long acquisition beep and then set the sensor back to the rest position. During acquisition the distance and diameter values are displayed on the display.	
40	Lower the wheel guard to run the balancing launch and to activate the SONAR device (in this way you automatic enter the width of the wheel).	

ALU1 Program Type selection





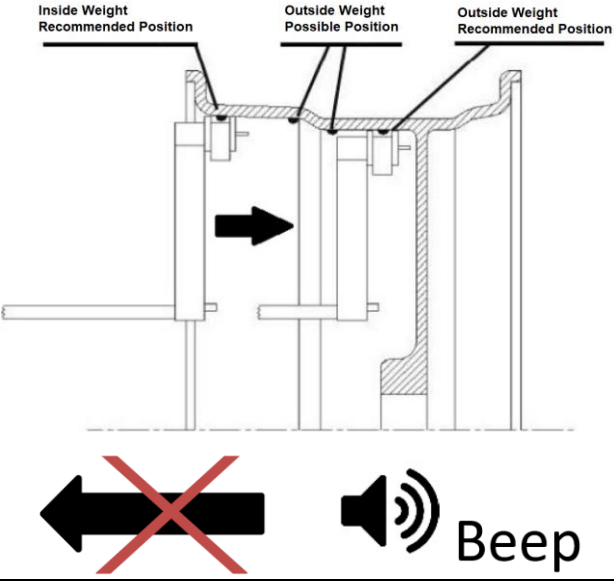
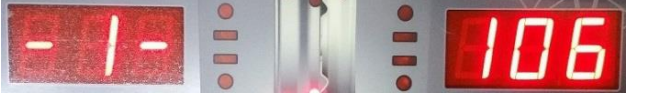

	Description	
10	Fit the wheel on the shaft and tighten with the ring nut.	
20	Take out the distance/diameter sensor and place it on the rim, as shown here. When the distance/diameter sensor come back in rest position, it is automatically activated the STANDARD program.	

30	Wait to hear the long acquisition beep and then set the sensor back to the rest position. During acquisition the distance and diameter values are displayed on the display.	
40	Press the keys  or  to activate the "ALU 1" program.	
50	Lower the wheel guard to run the balancing launch and to activate the SONAR device (in this way you automatic enter the width of the wheel).	

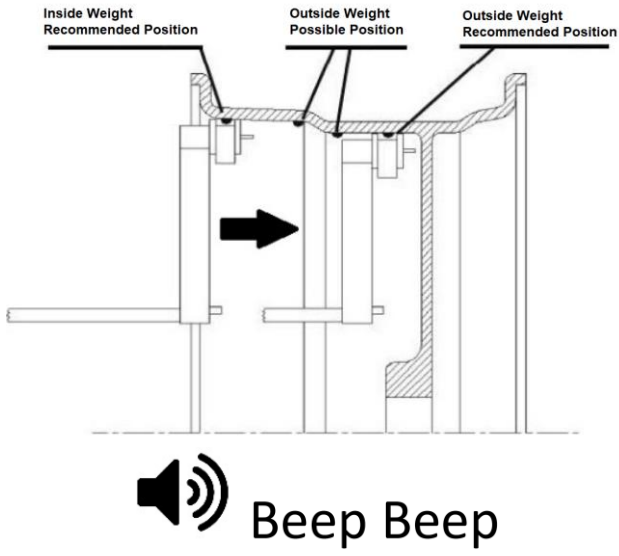
15.3.4 Automatic acquisition of the wheel dimensions for the ALS1, ALS2 program types (AAP - AUTOMATIC ALUMINUM PROGRAM)

	Description	
10	Fit the wheel on the shaft and tighten with the ring nut.	
20	<p>Extract the Distance/Diameter sensor and place it on the plane chosen as the internal plane. Wait to hear the short acquisition beep.</p> 	
30	Keep on sliding the Distance/Diameter sensor and place it on the plane chosen as the external plane.	

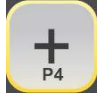

 <p>Inside Weight Recommended Position      Outside Weight Possible Position      Outside Weight Recommended Position</p> <p>Beep Beep</p>	
<p>40 Wait to hear the long acquisition beep and then set the sensor back to the rest position.</p> <p>The machine automatically starts the ALS2 program.</p>	
<p>50 The wheel dimensions have been acquired and the values can be displayed on the display.</p>	
<p>60 Press the keys  or  to activate the "ALS 1" program.</p>	

**Note** the acquisition of the inner position is confirmed by a long beep followed by a short beep while the acquisition of the outer position is confirmed by a long beep followed by two short beep.

15.4 Use of the special program types for ALS1 and ALS2 aluminium wheels  
 The machine has two special Program Types for aluminium wheels called ALS1 and ALS2. These two programs are different from standard Program Type for aluminium wheels (ALU1 up to ALU5) because the user is allowed to select the position where to apply the weights. This allows balancing aluminium wheels having particular shapes, difficult to perform with standard program where the weight are applied in precise positions. The difference between ALS1 and ALS2 program is that in ALS1 Program Type the user could select freely the outer balancing

positions (inner position) instead in ALS2 Program Type the user could select freely both of balancing positions.

The ALS1 or ALS2 program types use only the Distance/Diameter sensor to acquire and search for the balancing planes chosen by the user. The width sensor is not used.

The use of the ALS1 or ALS2 program types is divided into three parts:

- Guided acquisition of balancing planes (See paragraphs 15.3.2 and 15.3.4)
- Balancing spin;
- Search of the balancing planes for weight application.

#### 15.4.1 Balancing spin

Lower the wheel guard to run a balancing spin. Once the spin cycle is completed, the imbalance values calculated, according to the balancing planes chosen, will be displayed.

Moreover the machine will automatically set the mode for balancing planes search and will confirm it for about 1 second by displaying the message as shown in picture F15.11.

Picture F15.11: Message “Balancing planes research selected”



#### 15.4.2 Manual search of the balancing planes for ALS1 and ALS2 special program types without automatic acquisition

When a machine is not equipped with the automatic acquisition system by Distance/Diameter sensor or when the sensor itself has been disabled, you can still use the ALS1 or ALS2 special programs.

Since it is not possible to automatically acquire the two planes with the Distance/Diameter sensor, you must manually enter the two pairs of dimensions  $d_{i1}/d_{a1}$  and  $d_{i2}/d_{a2}$  as shown in chapter 15.3.2 Manual entering of the wheel dimensions for the ALS1, ALS2 program types. After the spin, the angular position of the balancing weights are indicated in table T15.6.

Table T15.6: Angular position of the balancing weights in the ALS1 and ALS2 Program Type without automatic acquisition system







Program Type	Internal Plane	External Plane	Static Plane
ALS1	H12	H6	H6
ALS2	H6	H6	H6

To find the rim planes you must extract the Distance/Diameter sensor and read the distance values  $d_{i1}$  or  $d_{i2}$  that you have previously set manually. At this point it is necessary to remind the selected planes and apply the weight in the angular position as described in table T15.6. In ALS1 Program Type mode the position  $d_{i1}$  always corresponds to the internal rim side.

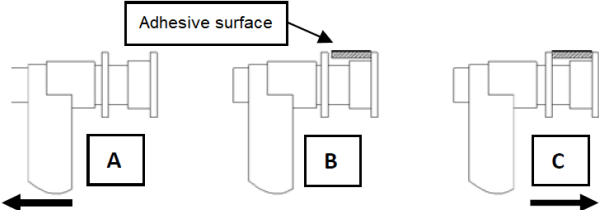

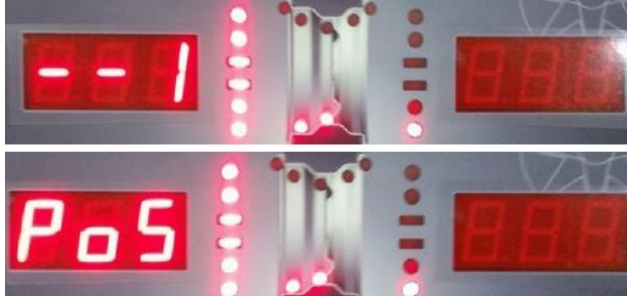

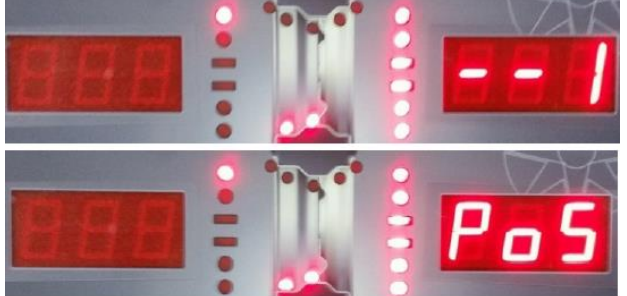
#### 15.4.3 Automatic search of the balancing planes for ALS1 and ALS2 special program types with distance/diameter sensor

The aim of the search of the balancing planes is to find the plans previously chosen by the operator in order to apply the balancing weights. Proceed as follows.

	Description	
--	-------------	--

10	Apply the weight shown on the left display (internal position) on top of the Distance/Diameter sensor gauge as shown in picture.	
20	Manually rotate the wheel until all the internal imbalance position leds light up (see picture F13.1 detail [4]). Block the wheel in this position using the pedal brake or electromagnetic brake (if present).	
30	Slowly extract the sensor until you hear the continuous beep indicating that the internal balancing plane has been reached. The left display helps the operator in this operation by indicating the direction in which the sensor must be moved.	
40	Block the Distance/Diameter sensor at this distance, then, rotate it until the adhesive weight sticks on the rim. The sensor contact point will be a midway position between 12 o'clock and 6 o'clock, depending on the rim diameter.	
50	Release the wheel and turn it by hand until all of the external imbalance position leds light up.	
60	Slowly extract the sensor until you hear the continuous beep indicating that the external balancing plane has been reached.	
70	Block the Distance/Diameter sensor at this distance, then, rotate it until the adhesive weight sticks on the rim. The sensor contact point will be a midway position between 12 o'clock and 6 o'clock, depending on the rim diameter.	
80	Lower the wheel guard to run the balancing launch. At the end of the launch, the imbalance data will be displayed.	

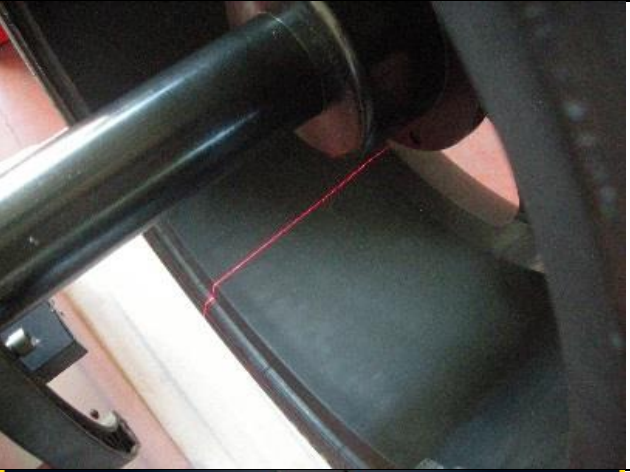
15.4.4 Automatic search of the balancing planes for ALS1 and ALS2 special program types with laser

	Description	
10	Fit the wheel on the shaft and tighten with the ring nut.	
20	Activate the STANDARD program by acquiring the wheel dimensions as described in chapter 15.3.4.	
30	Lower the wheel guard to run the balancing launch. At the end of the launch the imbalance data calculated based on the balancing planes will be displayed, and the LASER function will be activated in automatic.	
40	The laser pointer will identify the weight application positions on both internal and external (for ALS2) or only external (for ALS1) imbalance points. <b>The weights must always be applied at 6 o'clock.</b>	
50	Lower the wheel guard to run the balancing launch. At the end of the launch, the imbalance data will be displayed.	

15.4.5 Use of the ALS1 or ALS2 Program Type without the preliminary acquisition of balancing planes

It is possible to perform a spin when any Program Type is activated except for ALS1 or ALS2 and then select the ALS1 or ALS2 Program Type. The machine will calculate again the imbalance values according with the new Program Type selected. In this case the imbalance values displayed are calculated by means of the balancing planes (that is the two pairs of dimensions  $d_{i1}/d_{a1}$  and  $d_{i2}/d_{a2}$ ) acquired previously or, in the absence of these, by default.

## 16 Machine Calibration

To function properly, the machine must be calibrated. Calibration allows storing the mechanical and electrical parameters specific to each machine so provide the best balancing results.

### 16.1 When to carry out machine calibration

Table T16.1 lists the cases in which machine calibration should be carried out. Calibration must be carried out whenever one or more of the conditions listed are active.

Table T16.1: Conditions for machine calibration

Condition	Status	Who must perform
When the machine is first installed.	Mandatory	Technical Service Engineer
When the CPU-C1 electronic circuit board is replaced.	Mandatory	Technical Service Engineer
When a mechanical part linked to the pick-up signals (pick-up, pick-up compression springs, suspension unit + shaft) is replaced.	Mandatory	Technical Service Engineer
When the pick-up compression springs adjustment are modified.	Mandatory	Technical Service Engineer
When the encoder disc is replaced.	Mandatory	Technical Service Engineer
When a different motorbike adaptor is used since the last calibration for MOTO Wheel Type.	Mandatory	End User
When the machine doesn't show accurate results for balancing.	Recommended	End User
When there are wide and constant variations due to environmental humidity and temperature (for example seasonal changes).	Recommended	End User

The machine requires two independent calibrations:

- Calibration for the CAR/SUV Wheel Type (calibration is the same for both types of wheel).
- Calibration for the MOTO Wheel Type (wheels for motorbike).

It is not mandatory to perform both calibrations. If, for example, a user exclusively uses the machine to balance motorbike wheels, they must perform only calibration for the MOTO wheel type. Similarly, if the user exclusively uses the machine to balance auto vehicle/ off-road wheels (CAR/SUV) he must perform only calibration for the CAR/SUV wheel type. If the user instead uses the machine to balance all wheel types, he must perform both calibration. It does not matter the order in which the two calibration are performed.



















### 16.2 Machine calibration for the CAR/SUV Wheel Type

The calibration for the CAR wheel type and SUV wheel type is the same.

To perform machine calibration, you must first provide for the following material:

- A balanced wheel with steel rim that has the following dimensions: Diameter 15" Width 6". The distance of the wheel from the machine should be approximately 100 mm. It is also possible to use wheels with dimensions similar to those recommended as long as the difference is minor. It is not possible to use wheels with aluminium rims.
- A 50 grams weight (preferably in Iron or Zinc).  
To perform machine calibration, proceed as follows:

	Description	
10	Switch the machine on.	
20	Remove the wheels and any other accessory from the shaft.	

30	<p>Press [F+P3]  + . The display will show SER which indicates the activation of the SERVICE mode.</p>	
40	<p>Press [P3] . The display shows CAL CAR (machine calibration for auto-vehicles and off-road vehicles).</p>	
50	<p>Press [P3] </p>	
60	<p>Lower the wheel guard: the machine will run a launch. The machine will display CAL 1.</p>	
70	<p>Fit the wheel on the shaft. Enter the wheel dimensions with [P1]  [P2] , [P3]  to select the dimensions to be modified and [P4]  or [P5]  to change the values. If the dimensions of the wheel have been introduced before entering the calibration procedure, this step can be skipped. Lower the wheel guard: the machine will run a launch.</p>	
80	<p>Once the launch is completed, manually rotate the wheel until value 50 is seen on the left display. Apply the 50 g weight at the 12 o'clock position on the internal side of the wheel.</p>	
90	<p>Lower the wheel guard: the machine will run a launch.</p>	
100	<p>Remove the 50 g weight applied on the internal side.</p>	
110	<p>Manually rotate the wheel until a value of 50 appears on the right display. Apply the 50 g weight at the 12 o'clock position on the external side of the wheel.</p>	
120	<p>Lower the wheel guard: the machine will run a launch. For some models: keep the wheel guard lowered. It is equipped with the electromagnetic brake for positioning, at the end of the previous spin the machine will perform a set of short spins to calibrate the function of automatic stop on imbalance position.</p>	
130	<p>Calibration is finished: the machine automatically exits the calibration program and returns to NORMAL mode, ready to perform balancing.</p>	

If there are anomalies during the calibration procedure the machine will display an error message (for example Err 025). See the paragraph “22.1 Error codes” to solve the problem and continue/repeat/cancel the calibration procedure in progress.



The spins interrupted by pressing [P10] Stop or by raising the wheel guard may be repeat by lowering the wheel guard.

How to exit the CAR/SUV wheel type calibration

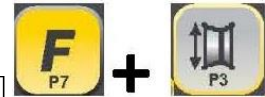

At any time it is possible to exit the calibration procedure by pressing [F+P3] keys. The machine will return to SERVICE mode displaying the writing SER SER. To return to the



NORMAL mode, press [F+P3] keys again. The calibration procedure in progress will be cancelled and the results will use previous calibration values.











### 16.3 Machine calibration for the MOTO wheel type

The calibration for MOTO wheel type (motorcycle wheels) is completely separated from CAR/SUV wheel type because in the calibration for MOTO a specific adaptor for motorcycle wheels is used and this slightly the shaft balancing.



If the calibration for MOTO wheel type has not been done and the user try to spin the wheel for balancing in the MOTO wheel type mode, the machine will not run and will display an error code ERR 031.

To perform the calibration for the motorcycle wheels proceed as follows:

	Description	
10	Switch the machine on.	
20	Mount the MOTO flange on the shaft.	

30	<p>Make sure that the hole on the shaft adaptor and one of the holes of adaptor itself are in line. Put the flange for motorcycles in the vertical position.</p>	
40	<p>Press [F+P3]  + . The display will show SER which indicates the activation of the SERVICE mode.</p>	
50	<p>Press [P3] . The display shows CAL CAR (machine calibration for auto-vehicles and off-road vehicles).</p>	
60	<p>Press [P3] . The writing CAL Mot will be displayed on the display (machine calibration for motorbike wheels).</p>	
70	<p>Press [P3]  to confirm. The message in the picture will be shown on the display.</p>	
80	<p>Lower the wheel guard: the machine will run a spin.</p>	
90	<p>At the end of the spin, the machine will display the writing h12 CAL.</p>	

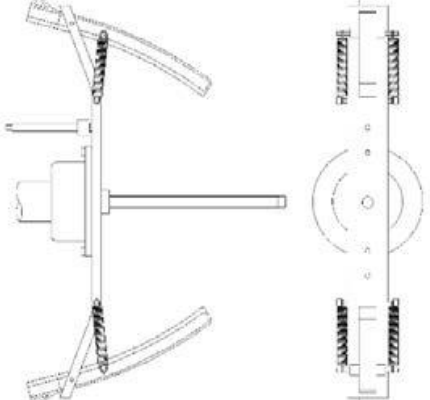

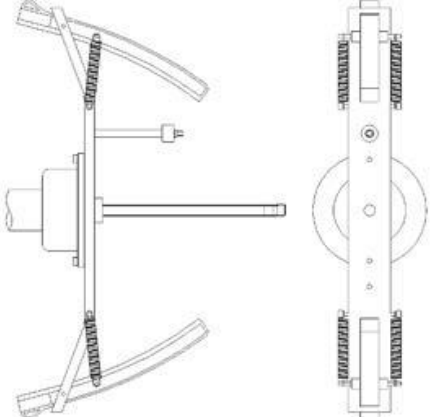
100	Apply the calibration weight on the internal side as shown in the picture. The calibration weight must be applied on the hole in the upper side. Move the motorcycle adaptor to a stable vertical position with the calibration weight in the upper side as shown in the picture. If the weight position is significantly different from the vertical position the machine will not spin and it will display an error code Err 043.	
110	Lower the wheel guard: the machine will run a spin.	
120	At the end of the spin, the machine will display the writing CAL h12.	
130	Apply the calibration weight on the external side as shown in the picture. The calibration weight must be applied on the hole in the upper side. Move the motorcycle adaptor to a stable vertical position with the calibration weight in the upper side as shown in the picture. If the weight position is significantly different from the vertical position the machine will not spin and it will display an error code Err 043.	
140	Lower the wheel guard: the machine will run a spin.	
150	At the end of the spin the MOTO wheel type calibration is finished and the machine will switch to NORMAL mode, ready to run the balancing.	

When the calibration is finished the MOTO wheel type and ALU1 Program Type value are set. Also the wheel data are automatically set by machine for this type of calibration. If you have anomalies during the calibration procedure, the machine will display the error message (for example Err 025). See the paragraph "2.2.1 Error codes" to solve the problem and continue/repeat/cancel the calibration in progress.



Spins interrupted by pressing [P10] Stop or by raising the wheel guard can be run by lowering the wheel guard.

How to exit the MOTO wheel type calibration

At any time it is always possible to exit the calibration procedure during its progress by pressing

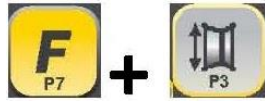

repeatedly [F+P3]

The machine will return to the SERVICE mode displaying the writing SER SER. To return to the NORMAL

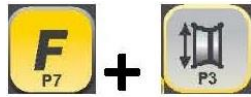



mode, press [F+P3] again. The calibration in progress will be cancelled and the machine will use the values of MOTO wheel type calibration which were previously stored. Also in this case the MOTO wheel type and the ALU1 Program Type will remain set. The wheel dimensions will be those which were automatically set by the machine for this kind of calibration.

## 17 Optimisation

The optimization program is used to minimize the amount of balancing weights to be applied on the rim by opposing the imbalance of the rim to that of the tyre. Therefore, use this program when the wheel requires the application of heavy balancing weights.

To enter in the Optimization Program proceed as follows:

1. Press [F+P4] . The display will show the options shown in picture

F17.1. Press [P4]  or [P5]  and choose the option oPt -1- to continue, or the

option oPt rEt to return to the operating program. Press [F+P4]  to confirm the chosen option.

Picture F17.1: Access to Optimization Program

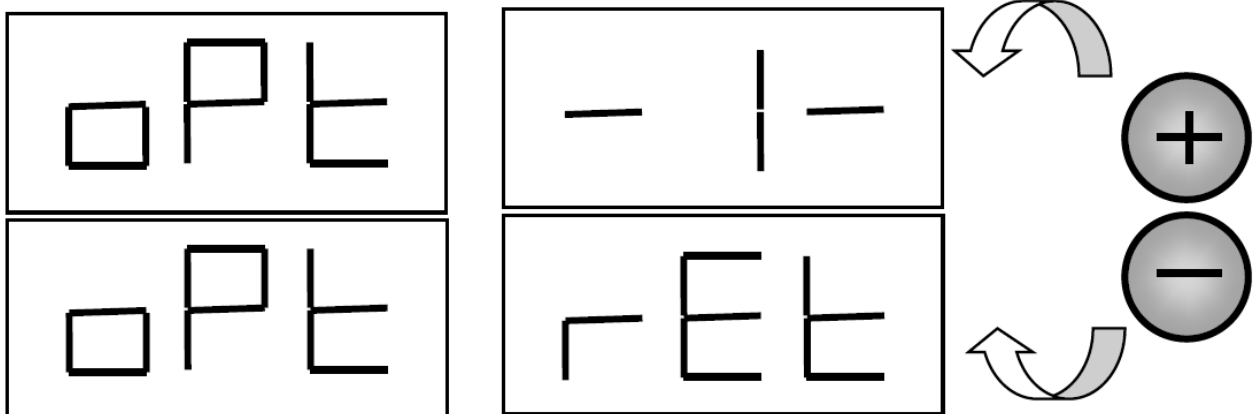

NOTE: at any time it is always possible to exit the calibration procedure by pressing repeatedly

[F+P4] 

2. If the wheel's static imbalance is less than 12 grams, the machine will display the message shown in picture F17.2 for a second and then will automatically exit the optimization program. If the wheel's static imbalance is instead greater than or equal to 12 grams, the

message shown in picture F17.3 will be displayed.

Picture F17.2: Optimization program not possible

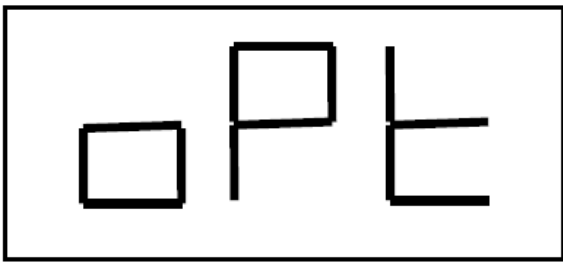

Picture F17.3: "Bring the valve to the 12 o'clock position" message

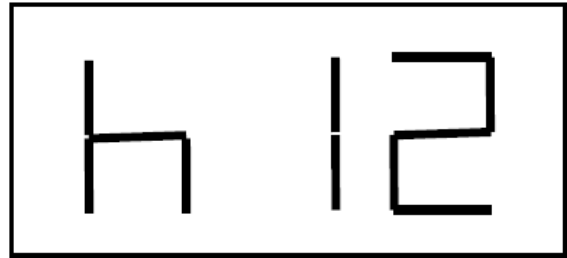
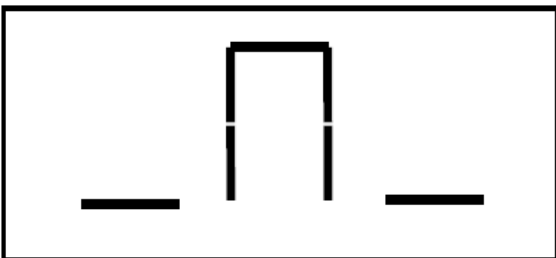

3. Bring the valve to the 12 o'clock position, mark the valve position on the tyre (see picture F17.4).

Picture F17.4: Reference mark on the tyre of the valve position

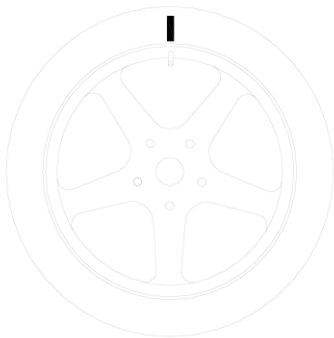

4. Press [P4]. The message seen in picture F17.5 will be displayed;

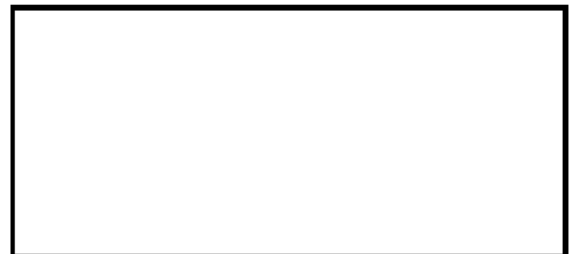
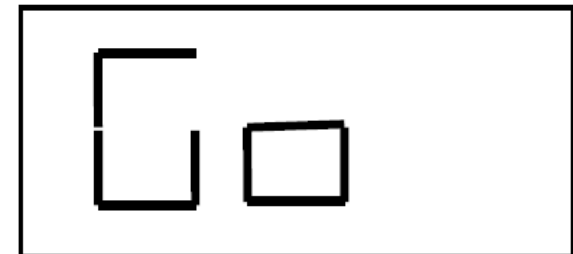



5. Remove the wheel from the shaft, remove the tyre bead, rotate it so that the mark is at 180° with respect to the valve (see picture F17.6).

Picture F17.6: Reference mark on the tyre at 180° from the valve





6. Remount the wheel on the shaft, erase the mark and run a launch.
7. At the end of the cycle, the message seen in picture F17.3 will be displayed. Two options are available:

- a) Bring the valve to the 12 o'clock position and press [P4]  to continue. In this case, the message seen in picture F17.7 will be displayed.

- b) Press [F+P4]  +  to exit the optimization program and to directly return to the operating program.

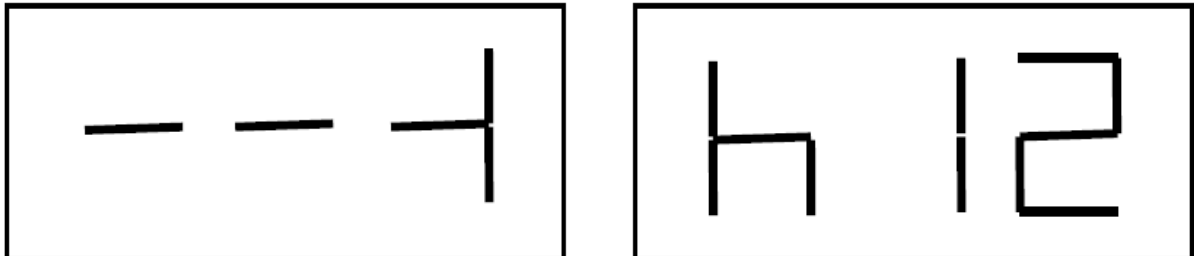
Picture F17.7: Final valve alignment with the mark on the tyre” message



8. Rotate the wheel until all position arrow LEDs light up and then mark the 12 o'clock position as shown in picture F17.4.
9. Remove the wheel from the balancing machine, remove the bead from the tyre and rotate it until the valve matches the mark on the tyre.
10. Optimization is complete: exit the optimization menu by pressing [F+P4]  + .
11. Remount the wheel on the balancing machine and balance it with the normal procedure.

## 18 Hidden Weights Program

This program divides the external weight "W" in two weights W1 and W2 (smaller than the initial external weight W) located in any two positions selected by the operator.

The two weights W1 and W2 must form a maximum angle of  $120^\circ$  including the external weight W, as shown in picture F18.1.

Picture F18.1: Hidden Weights Program: valid and invalid conditions for use in this example the balancing external weight W is indicated at 12 o'clock (H12) but can be at 6 o'clock (H6) or at 3 o'clock (H3): see text

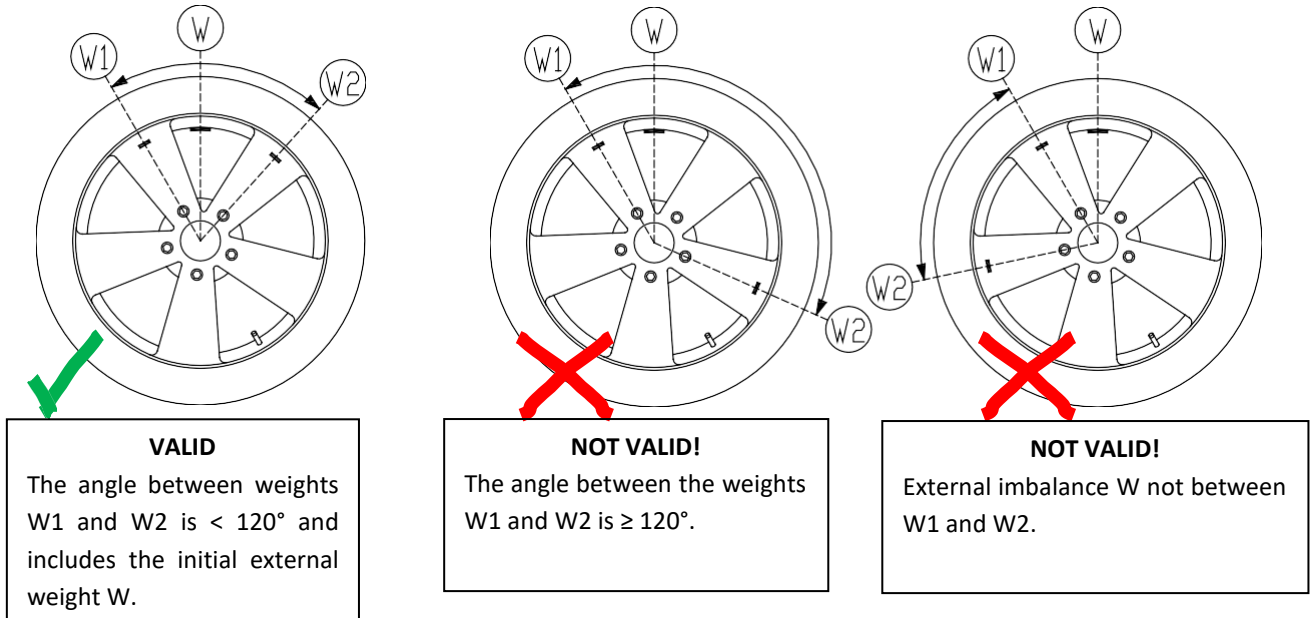

The Hidden Weights program is used for aluminum rims when:



- You want to hide the external weight behind two spokes for aesthetic reasons;
- The position of the external weights coincides with a spoke therefore a single weight cannot be applied.

**NOTE:** This program can be used with any Program Type and with any Wheel Type. It can also be used to divide the static weight into two separate weights (especially useful with wheels for motorbikes).

Hidden Weights program with sensors disabled

To use this program, proceed as follows:

1. Perform the balancing of the wheel without applying the external weights;
2. Rotate the wheel manually until all external imbalance search LEDs light up (see detail [9] of figure F18.1);
3. For easy of use make a reference mark on the tyre in the imbalance position at 6 o'clock.

4. Press [F+P5]  +  to run the Hidden Weights program. If the wheel is balanced on the external side, the machine will display error code Err 050 to signal that the operation is not allowed.
5. If there is an imbalance on the external side instead, the machine will display the message shown in picture F18.2;  
Picture F18.2: Input of the weight W1 position



NOTE: you can exit the “Hidden Weights” program at any time by pressing [F+P5]



6. Manually rotate the wheel anticlockwise up to the point where you want to apply the



external weight W1 and press [P1] to confirm. The angle formed by W1 and by the initial external weight W must be less than 120°.

7. If the angle chosen is higher than 120° the machine displays the error code Err 051, indicating another point to choose. If the angle instead is less than 120°, the machine will display the message shown in picture F18.3, allowing the operator to continue with the next step.

Picture F18.3: Input of the weight W2 position



8. Manually rotate the wheel clockwise passing the imbalance point (previously identified) up



to the point at which you want to apply the external weight W2 and press [P1] to confirm. The angle formed by the weights W1 and W2 must not be less than 120° and must include the external weight W.

9. If the external weight W is not included between the positions of the two weights W1 and W2, the machine displays the error code Err 052, thus indicating the operator to repeat the procedure from step 7. If the angle instead is less than 120°, the machine will immediately display the value of the external weight W2.
10. Block the wheel and apply the external balancing weight W2 as indicated on the display. Consult table T15.2 for the exact application point of the external weight.
11. Manually rotate the wheel until external weight value W1 does not appear on the left display.
12. Block the wheel and apply the external balancing weight W1 as indicated on the display. Consult table T15.2 for the exact application point of the external weight.

13. The Hidden Weights program procedure is complete: press [F+P5] to exit and run a balancing test launch.









NOTE: Picture F18.1 indicates the position of the external weight at the 12 o'clock position but this is valid only for certain Program Types. Table T15.2 shows the actual position of the external imbalance based on the Program Type and on the enabling state of Distance/Diameter sensor.









Hidden Weights program with sensors enabled

To use this program, proceed as follows:

1. Perform the balancing of the wheel without applying the external weight.
2. Rotate the wheel manually until all external imbalance search LEDs light up (see detail [9] of picture F18.1).

3. Press [F+P5]  +  to run the Hidden Weights program. If the wheel is balanced on the external side, the machine will display error code Err 050 to signal that the operation is not allowed.
4. If there is an imbalance on the external side instead, the machine will display the message shown in picture F18.2.
5. Manually rotate the wheel anticlockwise and with the sensor behind the first spoke;
6. Confirm by pressing .
7. The machine displays the message in picture F18.3.
8. Manually rotate the wheel anticlockwise passing the imbalance point and with the sensor behind the second spoke.
9. Confirm by pressing .
10. The display shows the two weights to be applied behind the two spokes.
11. Apply the weights W1 and W2 indicated on the display behind the two spokes with the sensor.
12. The Hidden Weights program procedure is complete: press [F+P5]  +  to exit and run a balancing test launch.

#### Hidden Weights program with LASER

	Description	
10	Apply the internal weight, stated on the left display, on the rim.	
20	Turn the wheel by hand until all of the external imbalance search LEDs light up at 6 o'clock.	
30	Press the keys [F+P5]  +  to activate the HIDDEN WEIGHTS program. If the wheel is balanced on the external side, the machine will display error code ERR 050 to signal that the operation is not allowed.	
40	Manually rotate the wheel anticlockwise and with the sensor behind the first selected spoke at 6 o'clock. Confirm by pressing [P6]  on the keyboard.	
50	Manually rotate the wheel anticlockwise passing the imbalance point and with the sensor behind the second selected spoke at 6 o'clock. Confirm by pressing [P6]  on the keyboard.	
60	Apply the weight behind the first selected spoke W1 at 6 o'clock.	

70	Apply the weight behind the second selected spoke W2 at 6 o' clock.	
80	The procedure of the Hidden Weights Program is finished: press	 to exit and launch the balancing test.

### 19 Second Operator

The machine has two separate memories allowing two operators to work simultaneously with different settings.

This feature can make operations at the workshop quicker because when, for example, an operator is busy with removing or remounting a tyre, the other operator can use the machine to perform balancing operations and vice versa. In this manual, the two operators are defined as operator 1 and operator 2. When operator 1 has completed his tasks on the machine or is involved in other activities, operator 2 can work with the machine using the settings for the wheel type he is working on without altering the settings entered by operator 1. When the machine is switched on, the two memories are set with the same values by default.

To use this function, operator 2 must proceed as follows:

1. When the machine is free, press [F+P6]  to select operator 2. The led located next to the button lights up to indicate that operator 2 is enabled. The message shown in picture F19.1 will be displayed for one second.

Picture F19.1: Enabling the memory of operator 2. The memory of operator 1 is stored

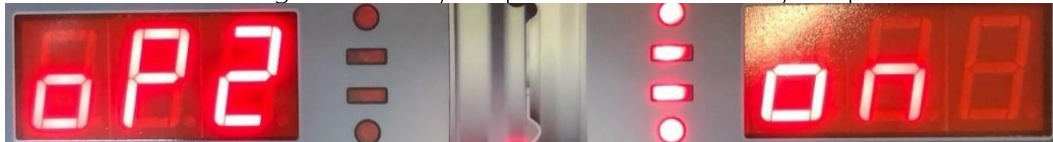

1. Perform all desired settings for wheel dimensions, Program Type, Wheel Type and unit of measurement. The settings of operator 1 are stored in memory.
2. Perform balancing of the wheel or wheels.
3. When operator 2 has finished his task on the balancing machine, operator 1 presses

[F+P6]  and thus restores all settings used by the latter. The LED located next to the button will turn off to indicate that operator 1 is enabled. The message shown in picture F19.2 will be displayed for one second.

Picture 19.2: Disabling the memory of operator 2. The memory of operator 1 is restored

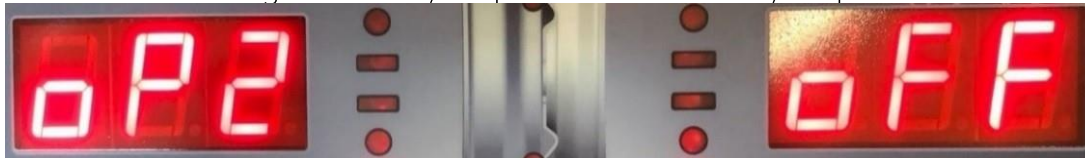

4. When operator 1 has completed his tasks on the balancing machine, the operator can press [F+P6] keys again to restore the wheel settings entered by him in step 2.
5. Tasks can continue, alternating the two operators.

An operator can change the following settings without editing the settings entered by other operators:

- Wheel dimensions (distance, width, diameter);
- Program Type (STD, ALU1);



- Wheel Type (CAR, MOTO, SUV);
- Unit of weight (grams or ounces);
- Unit of measurement of the wheel dimensions (millimetres or inches).
- Type of balancing weights material (Fe/Zn or Pb).

**NOTE:** the settings for the wheel's units of weight and dimension entered by operator 2 are not stored in the machine's permanent memory and therefore will remain active only until the machine is switched off.

## 20 Utility Programs

Utility programs are available only in NORMAL mode.



### 20.1 Selecting the imbalance display resolution

The machine has two wheel imbalance display resolutions. The two resolutions are defined as X1 (high resolution) and X5 (low resolution).

The resolution with which the imbalances of the wheel are displayed varies depending on the unit of weight as indicated in table T20.1.

Table T20.1: Display resolution

Set resolution	Imbalance unit of measurement	Display resolution	Notes
	Grams	1 Gram	
X1 (high)	Ounces	0.1 Ounce	
	Grams	5 Gram	
X5 (low)	Ounces	0.25 Ounce	The X5 resolution is set by default at start-up

To view the imbalance in X1 (high resolution) press [F+P1]  + . The machine will display the message visible in picture F20.1 for one second and the LED next to the button lights up. Imbalance values are now displayed in X1 resolution (high resolution).

Picture F20.1: Enabling of the imbalance display in high resolution



To return to viewing in X5 resolution (low resolution) press [F+P1]  +  again. The machine will display the message visible in picture F20.2 for one second and the LED next to the button will turn on. Imbalance values are now displayed in X5 resolution (low resolution).

Picture F20.2: Disabling imbalance view in high resolution

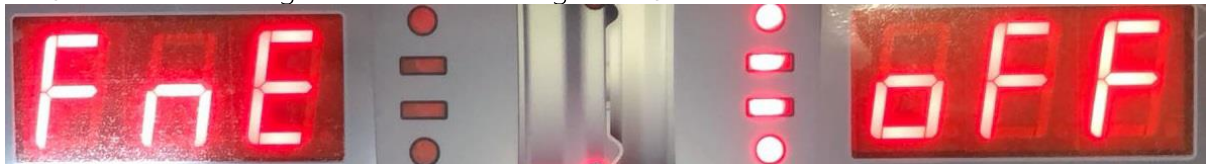

### 20.2 Selection of the static imbalance display

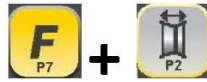

To view the static imbalance, press [F+P2]. The machine will show the static imbalance value on the display as seen in picture F20.3 and the LED next to the button lights up.

Picture F20.3: View of the Static imbalance display enabled. The right display indicates the entity of the static imbalance.

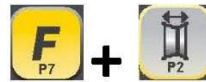
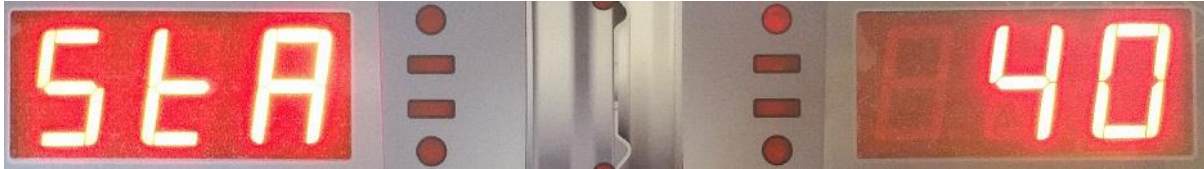

To return to the dynamic imbalance display, press [F+P2]. The LED next to the button will turn off.

**Note:** in some cases, static imbalance is forcibly set by the machine according to the current settings. For example, if the MOTO Wheel Type program is enabled and the width set is less than 4.5 inches, the machine will automatically set the static imbalance display.

### 20.3 Electromagnetic clamping brake (if present)

The electromagnetic clamping brake is useful to block the wheel in any position defined by the user and to simplify some operations such as the application or removal of balancing weights. If present, the electromagnetic clamping brake is also used in the automatic or manual stopping of the wheel on imbalance positions described in chapter 20.5 SWI Wheel stop procedure on the



positions of imbalance To activate the electromagnetic clamping brake, press [P9]. To



deactivate the electromagnetic clamping brake, press [P9] again.

The electromagnetic clamping brake is deactivated automatically in the following cases:

- Every time a balancing launch is run.
- Every time a SWI procedure is performed (stop of the wheel on the imbalance position) at low speed.
- After one minute of continuous activation (to avoid overheating of the brake itself).

The electromagnetic clamping brake can be used manually only in NORMAL mode. It cannot be used in the SERVICE mode.

### 20.4 Illuminator (if present)

The illuminator is quite useful because it allows shedding light on the internal part of the rim which is normally barely visible, thus making balancing operations easier.



To turn on the illuminator, press [F+P9]. To turn off the illuminator, press [F+P9]



again.

The illuminator is also automatically managed by the machine that turns it on in the following cases:



- When the Distance/Diameter sensor is extracted.
- After a wheel stop procedure on the position of imbalance (SWI procedure) which resulted in the balancing position of the internal weight.
- When the wheel itself is in the balancing position of the internal weight by manually rotating the wheel after a launch.

## 20.5 SWI wheel stop procedure on the positions of imbalance

Machines equipped with the electromagnetic clamping brake are capable of automatically stopping the wheel at the first imbalance angular position that is reached during rotation. This allows the operator to have the wheel in position ready for the application of the balancing weight thus increasing work and productivity speeds.

The procedure is referred to with the short English acronym SWI (Stop the Wheel on Imbalance). Within this manual, this acronym will be used to refer to the wheel stop procedure on the positions of imbalance. The SWI procedure has three different operating modes indicated in table T20.2.

Table T20.2: Types of SWI procedures available

SWI mode	When it is or when it can be run	Who can run the SWI procedure	Notes
Automatic	At the end of every launch.	Machine	This is performed only if there is at least one imbalance value on the wheel. Otherwise, conventional braking will occur.
Low speed	At the end of the launch, when the wheel is stationary and the wheel guard is raised.	Operator	Procedure started by pressing [P8]  key Start  : the wheel starts spinning at low speed until the first angular position of imbalance is reached.
Manual	At the end of the launch by manually rotating the wheel with wheel guard raised.	Operator	At each passage of the wheel in an angular position of imbalance, the electromagnetic clamping brake will be enabled for 30 seconds.

The three SWI modes have functions that are slightly different one from the other although, in all modes, the ultimate goal is to block the wheel at an angular position of imbalance and make operator's tasks quicker.

### 20.5.1 Automatic SWI procedure

During the automatic SWI procedure, the machine will measure rotational speed during braking at completion of the launch and, when this reaches a predetermined value, it will release the brake allowing the wheel to spin freely by inertia. When the speed is low enough, the machine will wait until the wheel passes through one of the angular positions of imbalance, therefore, it will enable the electromagnetic clamping brake.

**Note** for operator safety purposes, the SWI procedure will not be run when the MOTO Wheel Type is enabled.

### 20.5.2 SWI procedure at low speed

In the low speed SWI procedure, the wheel has already run the launch and is stationary. If the

operator presses [P8]  Start, with the wheel guard raised, the machine will apply slight acceleration to the wheel and then let it spin by inertia. When the speed is low enough, the machine will wait until the wheel passes through one of the angular positions of imbalance, therefore, it will enable the electromagnetic clamping brake.

**Note** for operator safety purposes, the SWI procedure will not be run when the MOTO Wheel Type is enabled.

### 20.5.3 Manual SWI procedure

In this mode, the SWI procedure is activated by manual rotation of the wheel if the wheel guard is raised. When the wheel passes through an angular position of imbalance, the machine will enable the electromagnetic clamping brake.

Angular positioning accuracy depends on many factors. Among the most important, they are: wheel dimensions and weight, adjustment of the electromagnetic brake, temperature, belt tension. In all cases, consider the following:

- If the electromagnetic clamping brake is disabled, the SWI procedure will not be run in any of three modes.
- If rotation speed decreases abruptly due to wheel inertia during the automatic SWI procedure or the low speed SWI (e.g. due to excessive friction with rotating mechanical parts) the machine applies a little extra acceleration to the wheel itself in order to reach the first angular position of imbalance. If, despite this, the wheel does not reach this position, the SWI procedure is aborted after 5 seconds and the machine displays the error code Err 042.
- When you use the manual SWI procedure, balancing precision will also depend on the speed with which the operator rotates the wheel: excessively high or low speeds reduce accuracy.

## 21 Service Mode



In this mode, the machine allows the user to enter certain settings (for example, selection of the units of measurement) or use special testing programs (to verify machine functioning) or configuration.

Some test and configuration programs are included in this Menu while the setting programs are available with direct access by means of the buttons. See table T1 3.2 to consult the full list of settings, programs and menus available in the SERVICE mode.

**Note:** some test or configuration programs are not available to the end user but only to technical support personnel.

To access the SERVICE mode, proceed as follows:

1. Switch the machine on and wait for completion of the initial test. After running the initial test, the machine will be in the NORMAL mode.

2. Press [F+P3]  + . The machine enters the SERVICE mode and will display the Ser Ser messages. See picture F21.1.

Picture F21.1: SERVICE mode enabled



3. To exit the SERVICE mode, you must first exit any Menus and test programs and return to the messages display shown in picture F21.1.

4. Press [F+P3]  +  the machine will return to the NORMAL mode.

### [P1] MENU Sensor calibration programs

The sensor calibration Menu is reserved for the technical support personnel and therefore is not described in this manual.

### [P2] Not used

This button is not currently used in SERVICE mode.

### [P3] Machine calibration

This button allows you to access the machine's calibration procedure as described in detail in chapter "16 Machine calibration".

### [P4] Select grams/ounces

This button allows you to display and/or change the unit of weight currently selected. The units available are grams (GRAM) and ounces (OUNCE).

DISPLAY OF CURRENT UNIT



To display the current unit of measurement briefly press [P4] . The unit selected is displayed for three seconds, after which the machine returns to display Ser Ser.

CHANGE OF CURRENT UNIT



To change the current unit of measurement, keep [P4]  pressed for three seconds. The new unit of measurement will be displayed, after which the machine returns to display Ser Ser. The unit of measurement selected is maintained even after the machine has been turned off.

### [P5] Select inches/millimeters

This button allows you to display and/or change the wheel's unit of dimension currently selected. The units available are inches (INCHES) and millimeters (MILLIM).  
DISPLAY OF CURRENT UNIT



To display the current unit of measurement briefly press [P5]. The unit selected is displayed for three seconds, after which the machine returns to display Ser Ser. Press any key to exit the display of the current unit without waiting three seconds.

### CHANGE OF CURRENT UNIT



To change the unit of measurement, keep [P5] pressed for three seconds. The new unit of measurement will be displayed, after which the machine returns to display Ser Ser. The unit of measurement selected is maintained even after the machine has been turned off.

### [P6] Select the imbalances view threshold

This button allows you to edit the imbalances view threshold. This procedure is intended for technical support personnel and is not described in this manual.

### [P9] Not used

This button is not currently used in SERVICE mode.

### [F+P1] Not used

This button is not currently used in SERVICE mode.

### [F+P2] Select weight material in Fe/Zn or Pb

This button allows you to select the balancing weight material. The options available are listed in table T21.1. The selection of the material type slightly changes the balancing results because the weights in Iron/Zinc are lighter than those in Lead and therefore are larger. The machine takes account of these differences when calculating the imbalance.

Table T21.1: Balancing weights materials

Option	Type of balancing weight material	Notes
Fe	Iron or Zinc	This material has been set by default.
Pb	Lead	In some countries (such as those of the European Community), Lead weights are prohibited by law.

### DISPLAY OF CURRENT TYPE OF MATERIAL



To display the current type of material briefly press [F+P2]. The type of material currently selected is displayed for three seconds, after which the machine returns to display Ser Ser.

Press any key to exit the display of the current type of material without waiting three seconds.

### CHANGE OF CURRENT TYPE OF MATERIAL



To change the current type of material keep [F+P2] pressed for three seconds. The new type of material will be displayed, after which the machine returns to display Ser Ser. The type of material selected is maintained even after the machine has been turned off.

**Note:** if Lead has been selected as material, at every machine start-up a message indicating the selection of this material will appear for one second after the initial test. See picture F21.2. This signal will not be viewed if Iron/Zinc is selected as material.

Picture F21.2: Selection of the Lead balancing weights

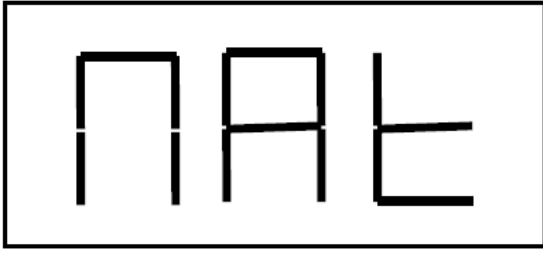

#### [F+P3] Exit the SERVICE mode

This button allows the machine to exit the SERVICE mode and return to the NORMAL mode.

#### [F+P4] Read launch number counter

By pressing this button, the total number of balancing launches run by the machine will be displayed. The number of launches is shown on both displays. Figure F21.3 shows an example of a machine's display that has run 1,234 balancing launches.

Picture F21.3: Display of the number of balancing launches

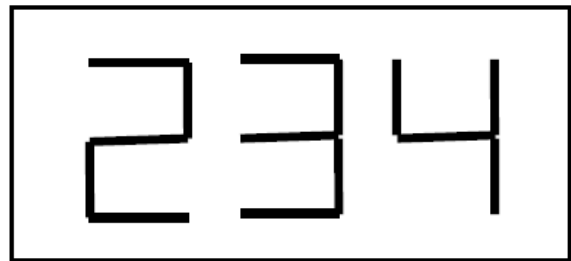
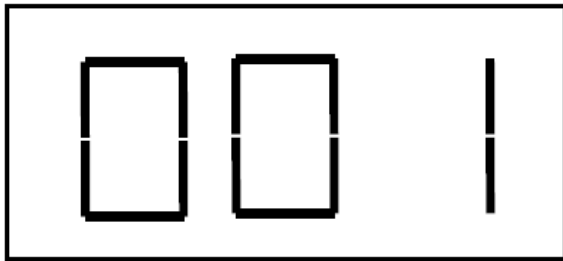

Balancing launches that were interrupted are not included in the total count of balancing

launches (for example, those stopped by pressing [P10]  Stop or those interrupted by raising the wheel guard) and all those run in the SERVICE mode.

#### [F+P5] Parameters

The Parameter menu is reserved for the technical support personnel and therefore is not described in this manual. Access to this menu is protected by password.

#### [F+P6] Not used

This button is not currently used in SERVICE mode.

#### [F+P9] MENU Test Programs

This menu allows you to run tests for some machine functions. The Menu has the following options:

- Enc Encoder disk test.
- RPM Number of shaft RPMs test.
- SIG Pick-up signals test.
- dPy Display test.
- tAS Keypad test.
- UFc Converter voltage-frequency test.
- SMO Shaft smoothness test.
- Ret Returns to the Service mode.

To scroll through the different menu options, press [P4]  or [P5]  until the desired option

is viewed, then press [F+P9]  +  to confirm the selection.

NOTE: the test programs listed are mainly reserved for technical support personnel but may also be run by end users as it does not impair machine operation.

### EnC Encoder disk test

This test allows you to control the function of the encoder which informs the machine of the angular position of the shaft. A number indicating the angular position will appear on the right display; this number must be between 0 and 255.

To exit the test program, press [F+P9]  + .

### RPM Number of shaft RPMs test

This test allows you to control the number of shaft RPMs during the launch. A number indicating the speed of the shaft will be viewed on the right display.

By pressing [P8]  Start the machine will run a launch and at the end of this will display the number of shaft RPMs.

To exit the test program, press [F+P9]  + .

### SIG Pick-up signals test

This program allows you to check the pick-up signal. To run the test, you will need to mount a balanced wheel with steel rim, 15" in diameter and 6" in width (or a similar as possible) on the machine. A 50 grams weight must be applied on the external side of the wheel.

By pressing [P8]  Start the machine will run continuous spinning and the pick-up signals to the three attenuation processes (Attenuation 1, Attenuation 2, Attenuation 4).



To complete the test, press [P10]  Stop or raise the wheel guard.

To exit the test program, press [F+P9]  + .

### dPy Display test

The display test program will light up all the LEDs and the 7-segment displays in sequence so you can check their functioning. To turn

on all the LEDs and display segments in sequence, press [P4]  or [P5] .

To exit the test program, press [F+P9]  + .

### tAS Keypad test



The keypad test program is used to check the operation of all the keys on the control panel. Every time a button is pressed the code of that key will appear on the display: for example, by pressing

[P8]  Start the code "P8" will be viewed.

The code of the key [P7]  is not displayed.

**NOTE:** To run the keypad test, the wheel guard must be raised or the display will always show the code of the [P10]  Stop

This occurs because the wheel guard and the [P10]  Stop button share the same input line to the electronic control board.

To exit the test program, press [F+P9]  + .

### UFc Converter voltage - frequency test

The converter voltage - frequency test shoes two numbers on the displays that represent the values of the internal conversion to the electronic control circuit board. These values are used by



technical support personnel to determine the functioning status of the circuit board.

To exit the test program, press [F+P9]  + .

### SMo Shaft smoothness test

This program allows you to measure the smoothness of the shaft.

These values are used by technical support personnel to determine the functioning status of the machine.

To measure the smoothness of the shaft proceed as follows:

1. Press [P8]  Start or lower the guard: the machine will perform a sequence of brief motor ignitions, each time letting the shaft run out of rotations for inertia;
2. Upon completion of the sequence the machine displays the value of the smoothness measured. The smoothness value is not absolute but refers to a sample machine whose smoothness value has been set at 1.00. The value measured is stored in the permanent memory of the machine in order to be used in the functions that are connected to the smoothness of the shaft.

To exit the test program, press [F+P9]  + .

### Ret Returns to the SERVICE mode

This Test Program menu option sets the machine back to the SERVICE mode.

## 22 Signals

When abnormal operating conditions occur the machine emits two types of signal:

- Error
- Warning

The Error signal is always accompanied by a triple beep indicating that the machine cannot run the command given by the operator, or, during operation, conditions were encountered that prevent the action in progress from continuing.

The warning signal is always accompanied by a double beep that prompts the operator to perform a particular action, or it refers to the fact that the machine has changed status. In any case, the requested operation is not prevented or the current function is completed.

## 22.1 Error codes

The machine indicates error conditions by alternating the display of the error code with a brief description (in English) of the cause of the error.

The list of error codes and brief descriptions are reported in table T22.1. The machine displays the code for different times depending on the code of said error, as indicated in the “Error displayed” column in table T22.1.

Table T22.1

Error code	Brief description	Error displayed(1)	Description	Notes
000 a 009	INT ERR		Machine parameters internal error.	Contact technical support.
010	REV SPN		Reverse rotation of the wheel.	Contact technical support.
012	NO STP		The wheel cannot be stopped at the end of the launch.	Check the mains voltage. If the checks do not lead to any results, contact technical support.
014	NO SPN		The wheel does not spin.	Contact technical support.
015	Codice del tasto incastrato	PERMANENT UNTIL TURNED OFF	Keypad blocked at start-up.	Release all buttons, then turn off or restart the machine. If the error persists, contact technical support.
016	DIS OUT	OPERATOR ACTION OR OPERATOR CONFIRMATION	Distance sensor is not in rest position at start-up of the machine or when [P8] Start is pressed.	Set the sensor to its rest position: the error should disappear. If the error persists, contact technical support. <b>NOTE:</b> if [F+P2] is pressed the machine acquisition system is temporarily disabled and operation can be continued. The disabled status will last until the machine has been turned off. The red LED [6] in figure F1.1 flashes to indicate the temporary disabled status.
017	LAR OUT	OPERATOR ACTION OR OPERATOR CONFIRMATION	Width sensor is not in rest position at start-up of the machine or when [P8] Start is pressed.	Set the sensor to its rest position: the error should disappear. If the error persists, contact technical support. <b>NOTE:</b> if [F+P2] is pressed the machine acquisition system is temporarily disabled and operation can be continued. The disabled status will last until the machine has been turned off. The red LED [6] in figure F1.1 flashes to indicate the temporary disabled status.
019	NO CP	OPERATOR CONFIRMATION	Communication processor failure.	Turn the machine off and then on again. If the error persists, contact technical support. The machine can still be used but all functions related to the USB port are disabled.

020	NO EEP	OPERATOR CONFIRMATION	Lack of communication with theeprom memory.	Turn the machine off and then on again.If the error persists, contact technical support.
021	EEP ERR	OPERATOR CONFIRMATION	Lack of machine calibration dataor incorrect calibration data.	Carry out calibration for the CAR/SUV Wheel Type and/or for the MOTO WheelType. If the error persists, contact technical support. See also ERR030and ERR031.
022 a 024		OPERATOR CONFIRMATION	Error during calibration.	Excessive imbalance or anomaly. Turnthe machine off and then on again. If the error persists, contact technical support.
025	SHF IMB	OPERATOR CONFIRMATION	Presence of weight during theCal0 calibration phase.	Remove the weight and repeat the launch of the Cal0 phase. If the error persists, contact technical support.
026	NO -A-	OPERATOR CONFIRMATION	A launch without weight or failureof the pick-up A signal in the Cal2 calibration phase.	Apply the intended weight and repeatthe launch. If the error persists, contact technical support.
027	NO -B-	OPERATOR CONFIRMATION	A launch without weight or failureof the pick-up B signal in the Cal2 calibration phase.	Apply the intended weight and repeatthe launch. If the error persists, contact technical support.
028	INN IMB	OPERATOR CONFIRMATION	Launch with weight on the internal side during the Cal3 calibration phase. In this phase, the weight must be on the external side.	Remove the weight from the internalside and repeat the launch. If the error persists, contact technical support.
030	CAR CAL	OPERATOR CONFIRMATION	Lack of calibration data for theCAR/SUV Wheel Type.	Carry out calibration for the CAR/SUVWheel Type.
031	MOT CAL	OPERATOR CONFIRMATION	Lack of calibration data for theMOTO (motorbike) Wheel Type.	Carry out machine calibration for theMOTO Wheel Type.
034	ALU -1-	OPERATOR CONFIRMATION	The MOTO Wheel Type is activated: a different Program Type other than ALU1 cannot be used.	Other Program Types cannot beselected.
039	W.GUARD		The wheel guard is open: therequested action cannot be performed.	
043	NO VRT	OPERATOR CONFIRMATION	The flange for motorbikes was not exactly vertical when [P8] Start was pressed during the MOTO Cal2 and Cal3	Put the flange for motorbikes exactlyvertical (and with the CAL reference on the upper part) then press [P8] Start. See chapter 16.3.

			calibration phases.	
046	NO DIA	OPERATOR CONFIRMATION	The Diameter sensor is enabled but disconnected.	NOTE: if [F+P2] is pressed the machine acquisition system is temporarily disabled and operation can be continued. The disabled status will last until the machine has been turned off. The red LED [6] in figure F1.1 flashes to indicate the temporary disabled status.
047	NO LAR	OPERATOR CONFIRMATION	The Width sensor is enabled but disconnected.	NOTE: if [F+P2] is pressed the machine acquisition system is temporarily disabled and operation can be continued. The disabled status will last until the machine has been turned off. The red LED [6] in figure F1.1 flashes to indicate the temporary disabled status.
051	TOO FAR	OPERATOR CONFIRMATION	Hidden Weights program: the selected point is too far from the external imbalance position.	The point must be included up to 120° from the external imbalance position. See chapter 18.
052	NOT INC	OPERATOR CONFIRMATION	Hidden Weights program: the external imbalance position is not between the selected W1 and W2 points.	Choose W1 and W2 points so that they include the external imbalance position. See chapter 18.
055	NO OPT	OPERATOR CONFIRMATION	The static imbalance of the wheel is too low: the Optimization program cannot be used.	

(1) The error code can be exited in the following ways:

OPERATOR CONFIRMATION

The machine exits from the error code display when the operator presses any key (except for

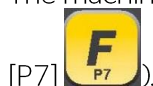

OPERATOR ACTION





The machine exits from the error code display when the operator performs an action linked to said error code (for example, ERR 016, brings the Distance sensor back to the rest position).

ONCE The machines display's once the error code and its brief description, the unit returns to the previous status.

PERMANENT

The machine permanently displays this error code until its turn-off, therefore the error code cannot be exited.

### 22.1.1 Replacement of the fuse

10	Turn the machine off and disconnect the power supply cable from the connector.	 
20	Remove the fuse holder.	
30	Replace the damaged fuse with a similar one (same amperage).	
40	Set back the machine working condition following backwards the steps described above.	

### 22.2 Warning codes

The machine alerts the operator of the warning codes by alternating display of the warning code with the brief description (in English) of the warning and remains in this status until the operator

has pressed any key (except for [P7] ).

Table T22.2: Warning codes

Warning Code	Description	Warning Displayed	Description	Notes
000			Reserved	
001	DO OPT	Once	Excessive wheel imbalance. use of Optimization program is recommended.	
002 to 010			Reserved	

### 22.3 Acoustic signals

The machine emits different acoustic signals based on its status. The acoustic signals are listed in table T22.3.

Table T22.3: Acoustic signals



Signal	Meaning	Notes
Short Beep	Selecting a program or a function	
Long Beep	Acquisition	Acquisition of a value. Acquisition of the wheel dimensions in the STD, ALU1, Program Types.
Long Beep + 1 Short Beep		Acquisition of internal plane in ALS1 or ALS2 Program Types.
Long beep + 2 Short beep		Acquisition of external plane in ALS1 or ALS2 Program Types.
Double beep	Warning	A particular condition has occurred that requires the operator's attention.
Triple Beep	Function not available or Error	The requested function is not available or an error condition has occurred.
Short Beep + Long beep	Storing one or more values in the permanent memory (eeprom) of the circuit board.	One or more values have been stored in the permanent memory of the circuit board (for example, at completion of calibration phases).
Intermittent beep	Adjustmen	Signal used in some service programs to simplify the adjustment of sensors.

The acoustic signal is also heard for about two seconds at machine start-up allowing the operator to check the operation of the alarm (buzzer).

## 22.4 Special visual signals

The machine gives special visual signals in certain cases. The special visual signals are listed in table T22.4.

Table T22.4: Special visual signals

Signal	Meaning	Notes
Three dots lit on one or both displays	Imbalance exceeds 999 grams.	This signal can be triggered due to: <ul style="list-style-type: none"> <li>• Lack of machine calibration;</li> <li>• Incorrect measures of the wheel dimensions;</li> <li>• Incorrect setting of the Wheel Type;</li> <li>• Incorrect setting of the Program Type.</li> </ul>
Flashing green STBY LED	The machine is in the STAND-BY mode.	All LEDs and displays are switched off. To exit the STAND-BY mode, press any button (except for [P7] key  ).
The left (or right) display is flashing	<ul style="list-style-type: none"> <li>a) Attending the user's command.</li> <li>b) The Diameter or Width sensor is not calibrated.</li> </ul>	<ul style="list-style-type: none"> <li>a) The user's command may be pressure of a key to confirm or continue the procedure in progress or the selection of a value or a menu option.</li> <li>b) Call the technical support to carry on with the calibration of the Diameter and Width sensor. To continue with the operation, you can temporarily disable the sensors by pressing     +  </li> </ul>
The sensors disabling LED is flashing	<ul style="list-style-type: none"> <li>a) Both of the sensors have been temporarily disabled.</li> <li>b) The width sensor has been temporarily disabled.</li> </ul>	The disabled status will last until the machine has been turned off. See chapter "14.1 Temporary disabling of the Distance and Diameter sensor" and "14.2 Temporary disabling of the width sensor".

23 Electrical System  
 Picture F23.1: Machine's wiring diagram

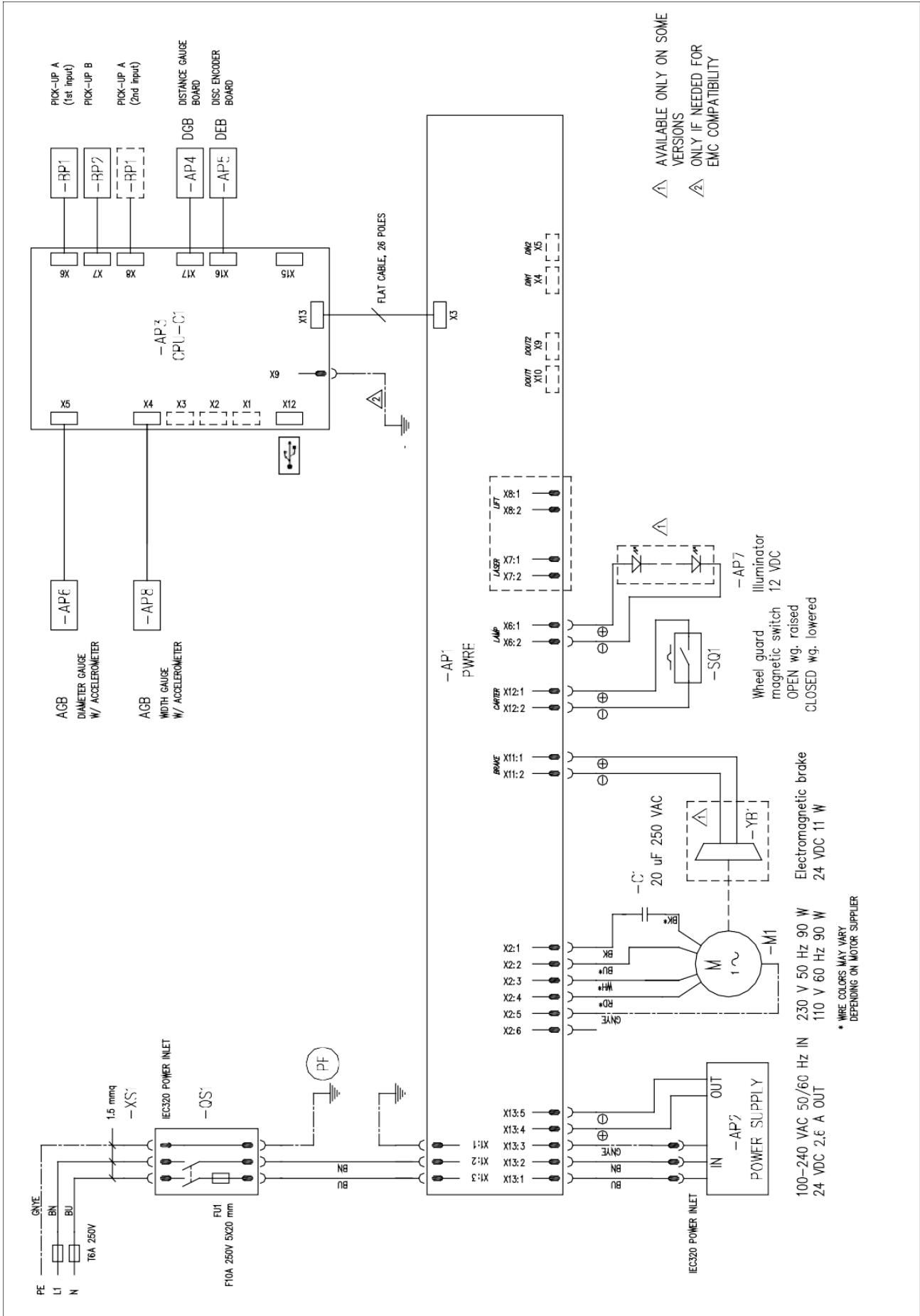



Table T23.1: Wiring diagram key

Reference	Description	Notes
AP1	PWRB power circuit board	
AP2	Power supply - AC input, DC output	
AP3	CPU-C1 control circuit board	
AP4	DGB circuit board for measuring the wheel's distance	
AP5	DEB electronic circuit to control wheel rotation	
AP6	AGB circuit board for measuring the wheel's diameter	
AP7	LED illuminator	Available only for some versions
AP8	AGB circuit board for measuring the wheel's width	
M1	Electric motor	
QS1	Switch with built-in fuse	
SQ1	Magnetic sensor for the position of protective casing	
YB1	Electromagnetic clamping brake	Available only for some versions

#### 24 Diagnostics & Efficiency of Accessories

In some cases, by refitting the wheel on the wheel balancer, the machine could show some more unbalance which is for sure due to the not equal fitting of the tyre on the machine shaft as originally.

Some little differences in weight within 15gr (matter of fact it is always half the shown value: i.e. 10 shown gr = 5 unbalance gr) could be considering normal as for the wheels fixed on the cone. And it also depends on the tolerance of the counterweights.

Whether remounting a zero balanced wheel some unbalance value over 10 gr are displayed, it is necessary to check the conditions of the accessories and replace on them the parts which are no longer in perfect conditions due to bending, hurts, use, unbalance of the flanges.

The accessories check enables to control whether their use had modified the mechanical clearance.

Kindly do not forget that when using the centering cone, the repeated results could be similar only if the central hole is not ovalized and consequently not centered. Should this is the situation, better results could be obtained centering by the fixing holes (see the flange below).



## 25 Fire Prevention

	Dry materials	Flammable liquids	Electrical equipment
Hydraulic	YES	NO	NO
Foam	YES	YES	NO
Powder	YES*	YES	YES
CO <sub>2</sub>	YES*	YES	YES

YES\*: Can be used in the absence of more appropriate means or for small fires.

The information in the table above is general and can be used as a rough guide. The responsibility for the use of each type of extinguisher must be obtained from the manufacturer.

**Continental Automotive Trading UK Ltd**

36 Gravelly Industrial Park,  
Birmingham,

B24 8TA

Tel: 0121 725 1234

Email: [salesorders@continental-corporation.com](mailto:salesorders@continental-corporation.com)

[www.continental-aftermarket.com/gb-en](http://www.continental-aftermarket.com/gb-en)

**Legal notice**

The information in this brochure contains only general technical descriptions and performance characteristics, the applicability of which can depend on further factors in case of actual use. It is not meant or intended to be a specific guarantee of a particular quality or durability.

An obligation to provide the respective characteristics shall only exist if expressly agreed in the terms of contract. We reserve the right to make changes in availability as well as technical changes.